

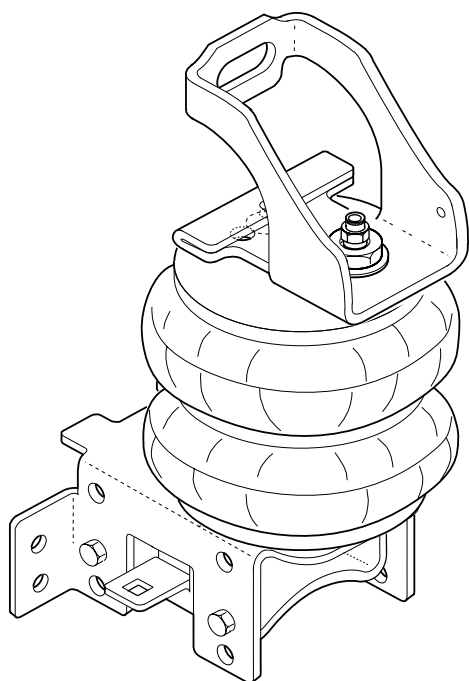

riderite.com

# INSTALLATION INSTRUCTIONS



**SECTION 1 - AIR SPRING**

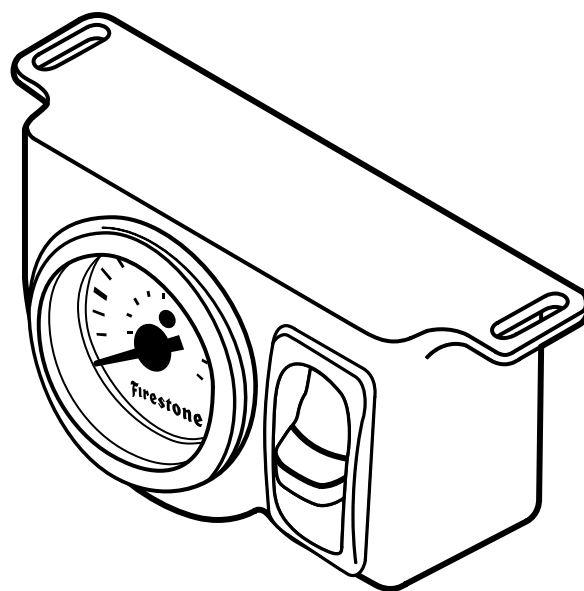

**SECTION 2 - AIR ACCESSORY**

**Firestone**

*World's Number 1  
Air Spring.*



FIRESTONE INDUSTRIAL PRODUCTS COMPANY

# ! IMPORTANT

*PLEASE DON'T HURT YOURSELF, YOUR KIT OR YOUR VEHICLE. TAKE A MINUTE TO READ THIS IMPORTANT INFORMATION.*

**DO NOT INSTALL IF THE TRUCK HAS BEEN LIFTED AND THE STOCK JOUNCE BUMPER SPACERS ARE NOT ON THE VEHICLE.** *This kit is to be used on a **pickup truck only**, and **DOES NOT INCREASE YOUR VEHICLE'S MAXIMUM LOAD.***

## **SAFE INSTALLATION**

Please take all safety precautions during installation. A hydraulic jack can fail, and if that happens, you can be seriously hurt, or worse, if you are relying on it to hold up the vehicle. If you use a hydraulic jack, secure jack stands in the appropriate locations and chock any tires still touching the ground.

Wear safety glasses or goggles. Your eyes may be lower than some parts and pieces, and you don't want to lose an eye.

Remove the possibility of any electrical issues by disconnecting the negative battery cable.

## **KIT CLEARANCE**

There must be a minimum of 1/2" clearance around all installed components when the Air Springs are inflated and under a load. The Air Springs must flex and expand during operation, so the clearance keeps the kit from rubbing against parts of the vehicle.

## **VEHICLE GVWR**

NEVER exceed the maximum load recommended by the vehicle manufacturer (GVWR). The GVWR can be found in your vehicle's owner's manual or on the data plate on the driver's side door. Consult your local dealership for additional GVWR specifications.

## **INFLATING THE AIR SPRINGS**

When inflating Air Springs, add air pressure in small quantities, checking air pressure frequently. The Air Springs have much less air volume than a tire, so they inflate much more quickly.

## **PRESSURE TO LOAD**

The Air Springs will support approximately 50 lbs. of load for each PSI of inflation pressure (per pair). For example, 50 PSI of inflation pressure will support a load of 2500 lbs. per pair of Air Springs.

## **APPROPRIATE AIR PRESSURE**

For best ride, use only enough air pressure in the Air Springs to level the vehicle when viewed from the side (front to rear). This will vary, depending on the load, location of the load, condition of the existing suspension, and personal preference.

## **OPTIONAL T-FITTING**

This kit includes Inflation Valves and Air Line Tube for each Air Spring, allowing you to compensate for unbalanced loads. If you prefer a single Inflation Valve system to provide equal pressure to both Air Springs, your dealer can supply the optional "T" fitting (Part # 3025 or WRI-760-3461 retail pack).



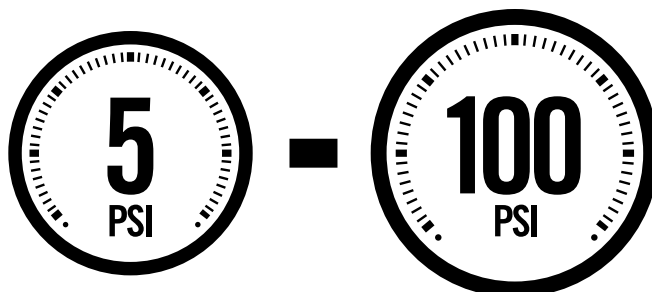



**ONCE INSTALLED SUCCESSFULLY, FOLLOW THESE PRESSURE REQUIREMENTS FOR THE AIR SPRINGS:**



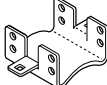
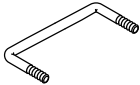

# SECTION 1 PARTS

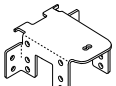
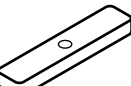
Compare the parts below to your kit. Assure you have all pieces, and organize them for an easier installation.















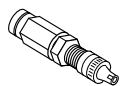



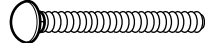

## AIR SPRING CONTENTS

PART # 6401	 x2 AIR SPRING	PART # 6379	 x2 SADDLE BRACKET	PART # 3077	 x2 BAIL CLAMP
PART # 5572	 x2 UPPER BRACKET	PART # 1163	 x2 AXLE STRAP BRACKET	PART # 1004	 x1 HEAT SHIELD
PART # 5380	 x2 LOWER BRACKET	PART # 6477	 x2 1/2" SPACER	PART # 9414	 x1 AIR LINE TUBE (18 FEET)

## A24-760-7560 INFLATION VALVE BRACKET KIT

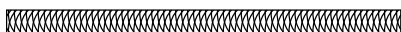
PART # 9483	 x1 NO-DRILL INFLATION VALVE BRACKET	PART # 9488	 x2 LARGE NYLON TIE
-------------	---	-------------	---

## AIR SPRING HARDWARE PACK

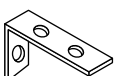
PT # 0065	 x1 5/16" - 24 x 3/4" HEX HEAD BOLT	PT # 3067	 x18 3/8" - 16 FLANGE LOCK NUT	PT # 3296	 x2 3/4" LOCK WASHER
PT # 3056	 x1 5/16" - 24 FLANGE NUT	PT # 0632	 x2 3/8" LARGE FLAT WASHER	PT # 3032	 x2 INFLATION VALVE AND VALVE CAP ASSEMBLY
PT # 3033	 x4 5/16" FLAT WASHER	PT # 3350	 x2 3/4" - 16 x 1 3/4" HEX HEAD BOLT	PT # 3046	 x2 AIR FITTING
PT # 3069	 x2 3/8" - 16 x 3/4" FLANGE BOLT	PT # 3295	 x4 3/4" - 16 HEX NUT	PT # 3012	 x4 3/8" - 16 x 3" CARRIAGE BOLT
PT # 3411	 x2 3/4" THICK WASHER	PT # 3412	 x2 3/4" - 16 FRAME NUT	PT # 9036	 x15 RED NYLON TIE
PT # 0070	 x8 3/8" - 16 x 1" HEX HEAD BOLT	PT # 3064	 x2 INTERNAL TOOTH LOCK WASHER	PT # 0899	 x4 THERMAL SLEEVE
PT # 3345	 x2 3/8" - 16 x 2 1/2" FLAT HEAD BOLT	PT # 3113	 x8 3/4" FLAT WASHER	PT # 3328	 x2 3/4" - 16 x 3" HEX HEAD BOLT
PT # 5428	 x1 FUEL LINE RELOCATION BRACKET				

# CONTENTS AND OVERVIEW

## SECTION 1

PAGE **4** REMOVE JOUNCE BUMPER, MOVE FUEL LINE AND BEGIN UPPER BRACKET INSTALL

PAGE **5** FINISH UPPER BRACKET INSTALL

PAGE **6** FASTEN AIR SPRING TO UPPER BRACKET

PAGE **7** INSTALL LOWER BRACKET ASSEMBLY

PAGE **8** SECURE LOWER BRACKET

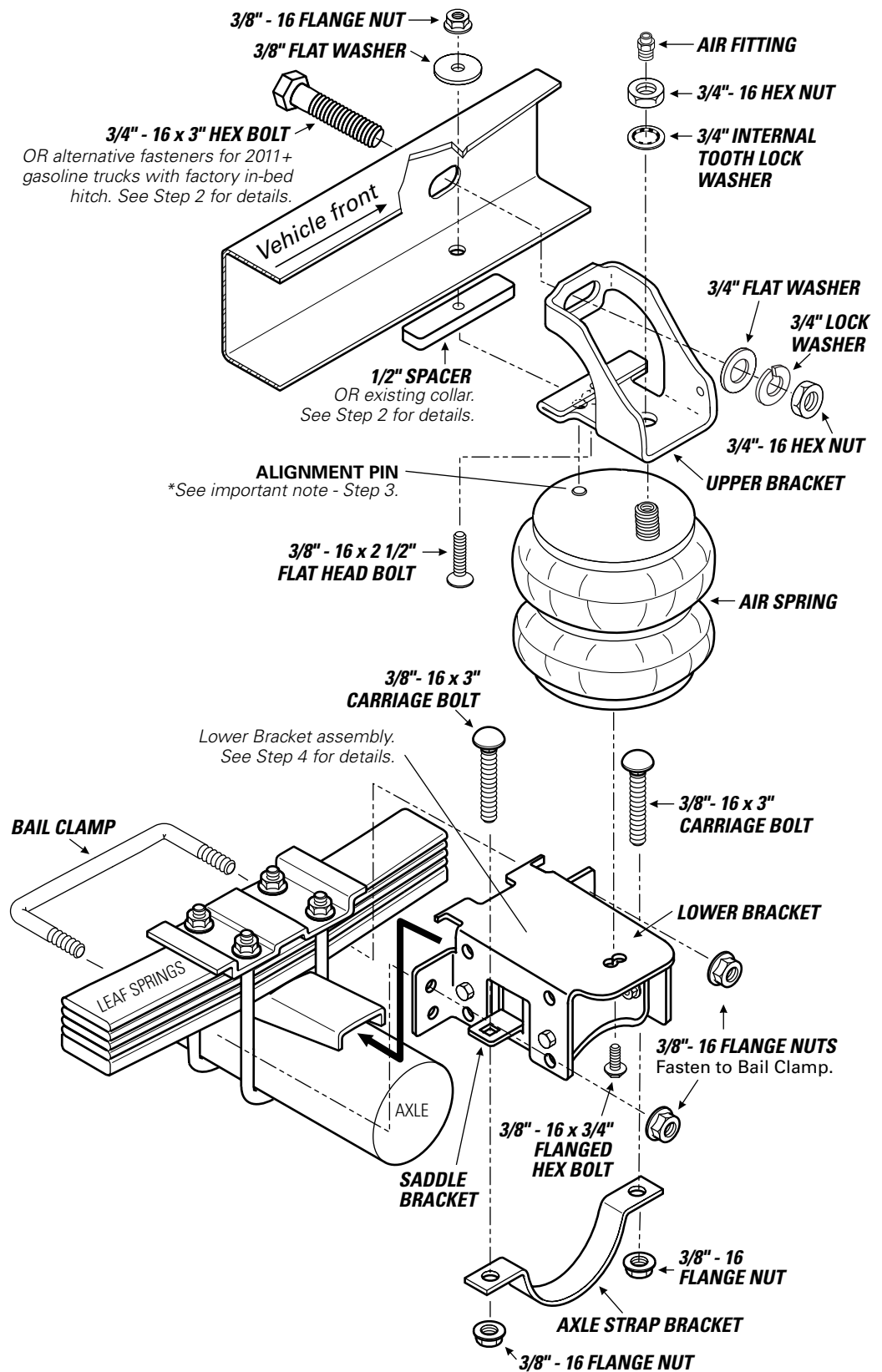

# 1

## REMOVE EXISTING JOUNCE BUMPER & INSTALL RELOCATION BRACKET

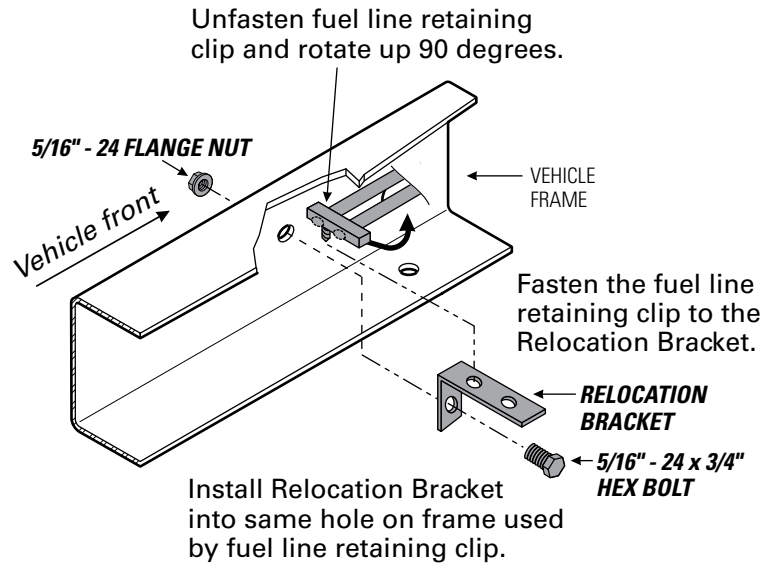
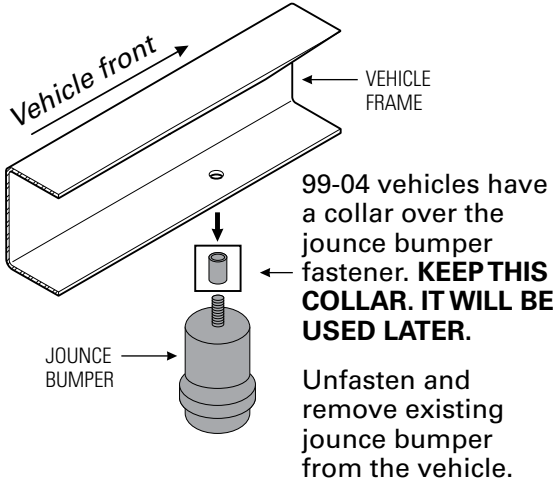
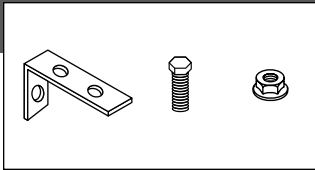

# 2

## BEGIN UPPER BRACKET INSTALLATION

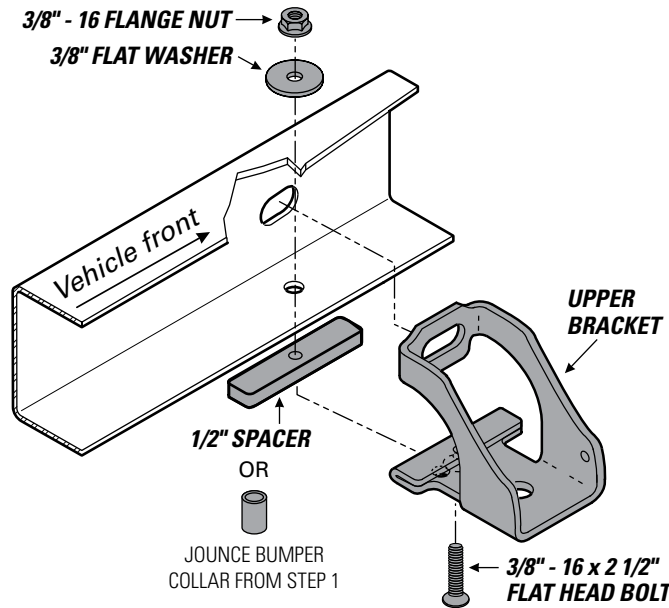
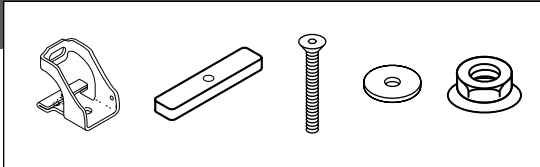

IF YOUR VEHICLE HAS THE COLLAR FROM STEP 1, IT MUST BE USED INSTEAD OF THE SPACER.

# 3

## FINISH UPPER BRACKET INSTALLATION

### A INSTRUCTIONS FOR ALL TRUCKS EXCEPT 2011+ GAS WITH FACTORY IN-BED HITCH

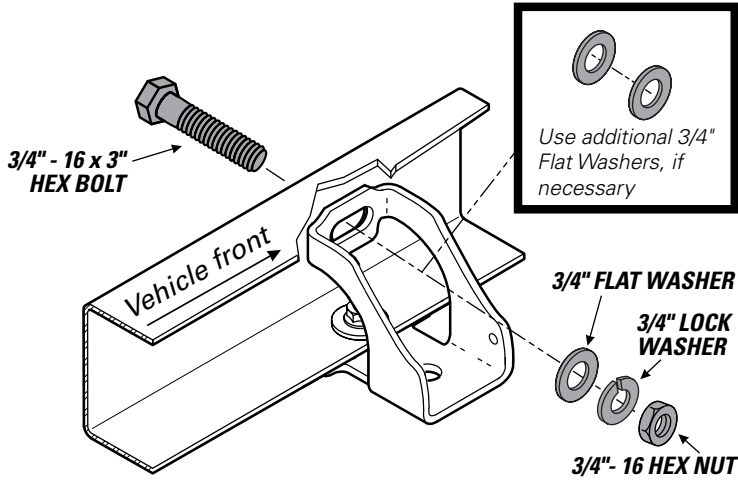
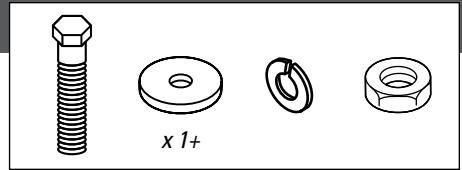

### B INSTRUCTIONS FOR 2011+ GAS TRUCKS WITH FACTORY IN-BED HITCH

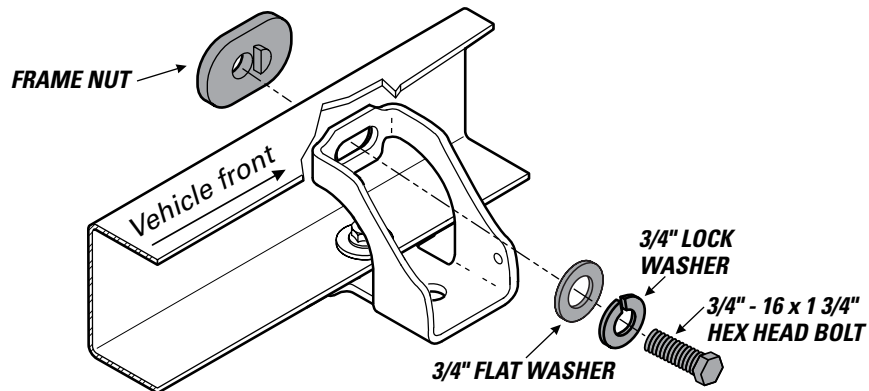
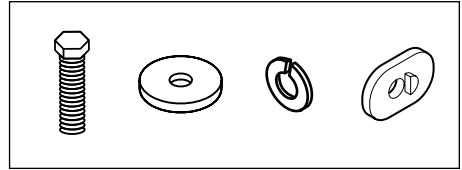

REMOVAL OF EXISTING IN-BED HITCH HARDWARE MAY BE REQUIRED.

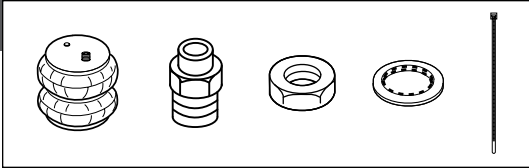

INSTALLING THE RIGHT SIDE? REMEMBER TO INSTALL THE HEAT SHIELD IN STEP 7 FIRST!

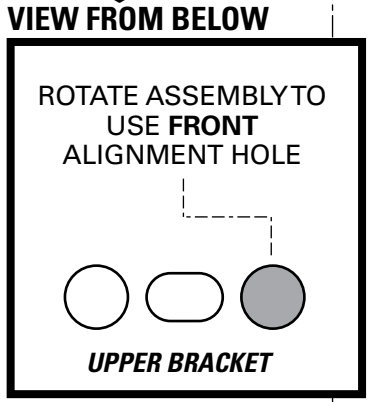
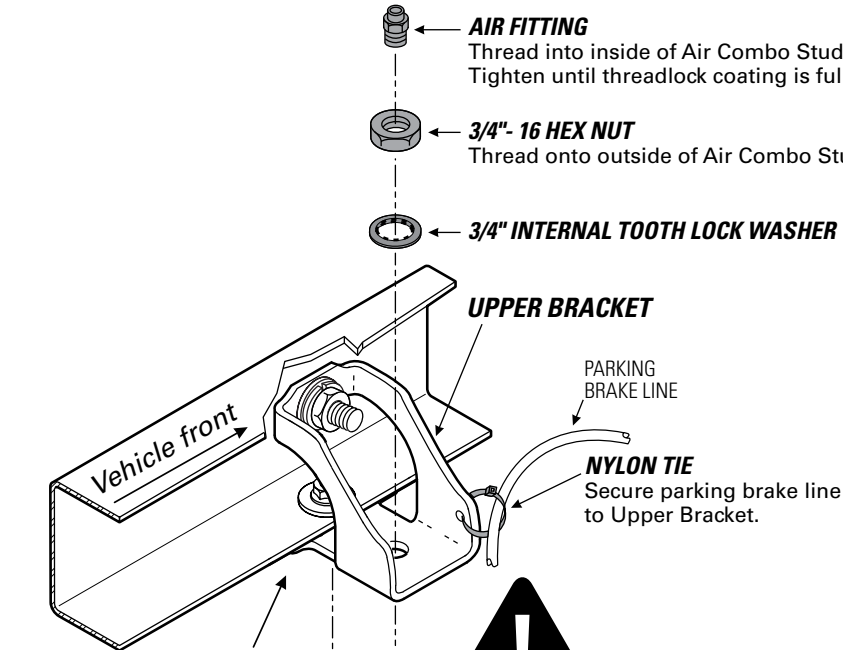

ALIGNMENT PIN ON AIR SPRINGS MUST BE INSTALLED TO FULLY SEAT INTO THE FRONT ALIGNMENT HOLE IN THE UPPER BRACKET. FAILURE TO DO SO WILL CAUSE IT TO BE PUSHED INTO THE BEAD PLATE, CREATING AN AIR LEAK, AND RESULTING IN AN AIR SPRING FAILURE THAT IS **NOT WARRANTABLE. THE ALIGNMENT PIN CANNOT HOLD 2,500 LBS! IT IS USED FOR ALIGNMENT ONLY!**

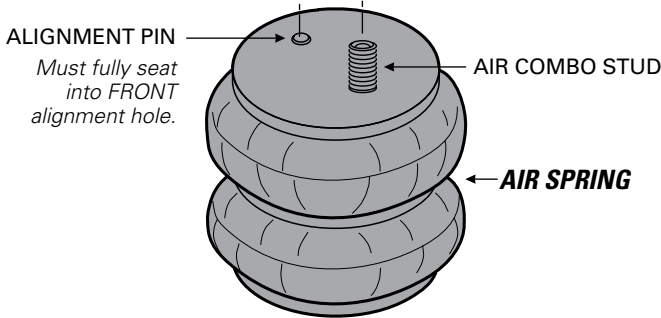

# 5

## INSTALL LOWER BRACKET ASSEMBLY

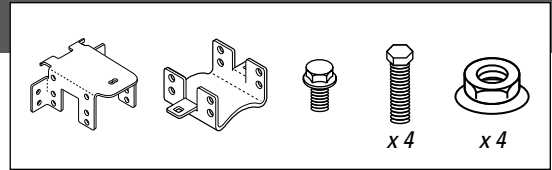

**1** Follow steps below to dry fit assembly. Make alignment marks as shown.

**2** Place bottom of Lower Bracket on the axle of the vehicle.

**3** Place the Upper Bracket above the Lower Bracket as shown. Assure both are tight against the leaf spring stack.

**4** Match the alignment marks and secure the Air Spring to the Upper Bracket, as shown.

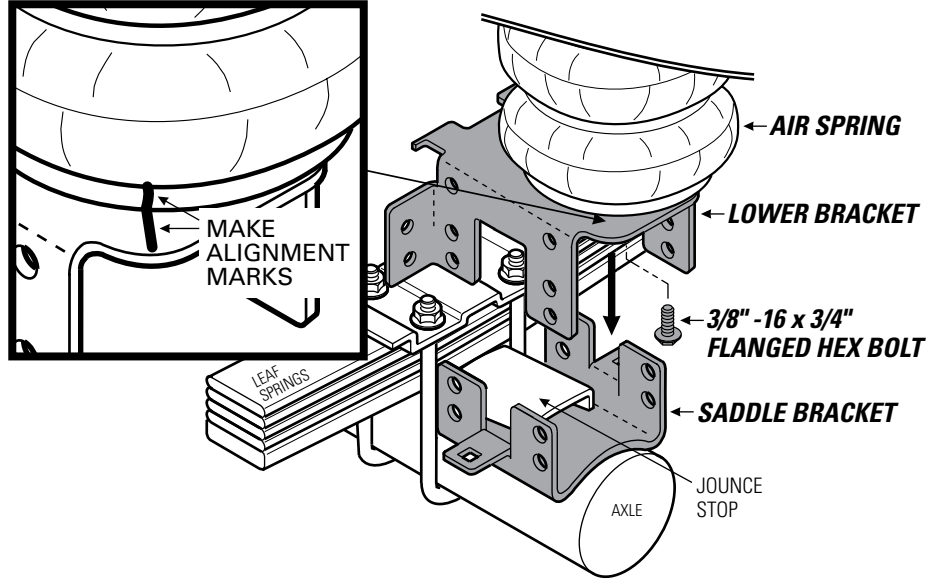

**5** Position the Lower Bracket as low as possible, while still clearing the jounce stop on the vehicle.

**6** Choose the bolt holes in both brackets that best line up with the Lower Bracket with the Saddle bracket. Make sure the Lower Bracket is parallel to the ground.

**7** Use supplied fasteners in the bracket holes you chose.

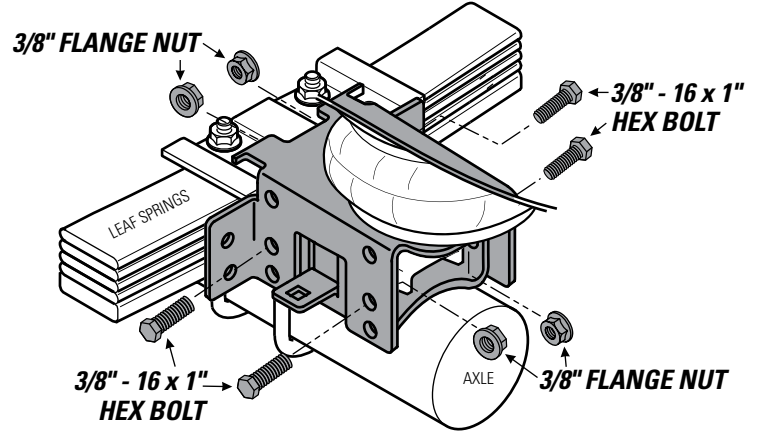

### ! IMPORTANT: INSTALL ON THE LOWEST SETTING POSSIBLE FOR YOUR VEHICLE

FAILURE TO DO SO CAN RESULT IN DAMAGED BRACKETS AND CAN VOID YOUR WARRANTY

#### 4-WHEEL DRIVE INCORRECT

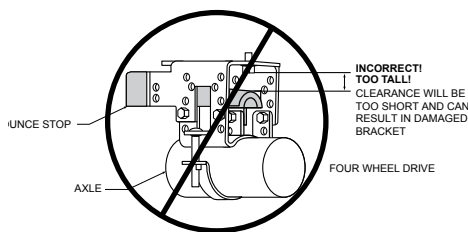

#### 4-WHEEL DRIVE CORRECT

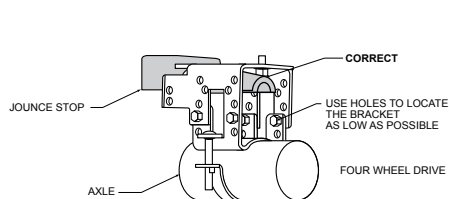

#### 2-WHEEL DRIVE CORRECT

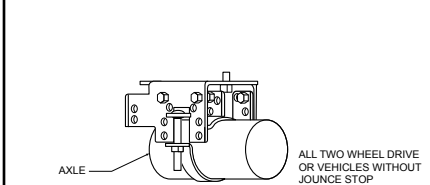



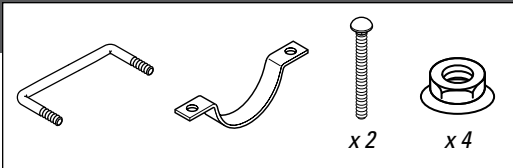

USE YOUR HAND TO CHECK FOR THE PROPER CLEARANCE AROUND THE AIR SPRING. IF YOUR HAND DOES NOT FIT BETWEEN THE AIR SPRING AND OTHER COMPONENTS, IT WILL RUB!

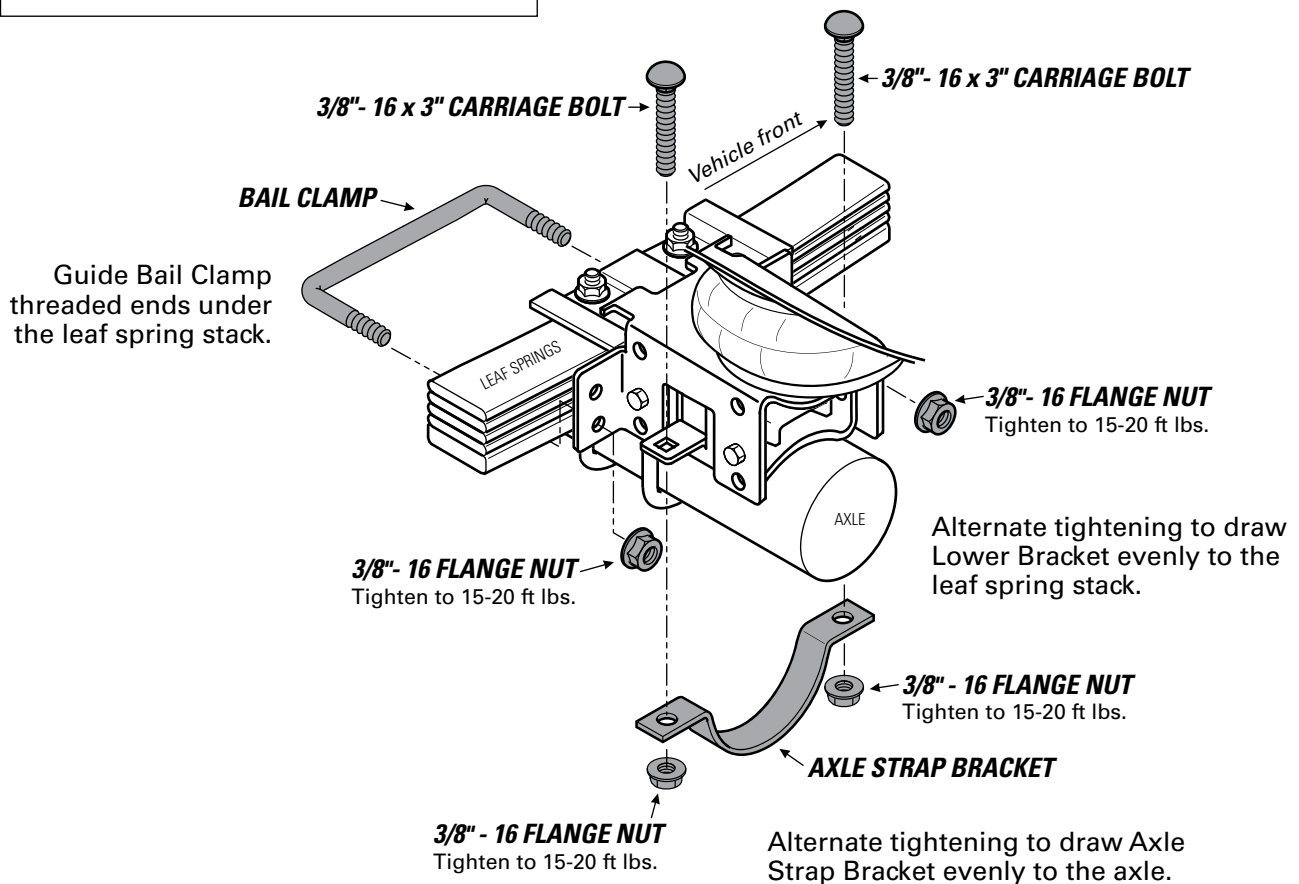

**AWESOME!** You're done with the left side. The right side is the same, with the addition of the Heat Shield. See Step 7, then complete the steps for the right side installation.

# 7

## INSTALL RIGHT SIDE WITH HEAT SHIELD

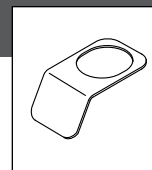

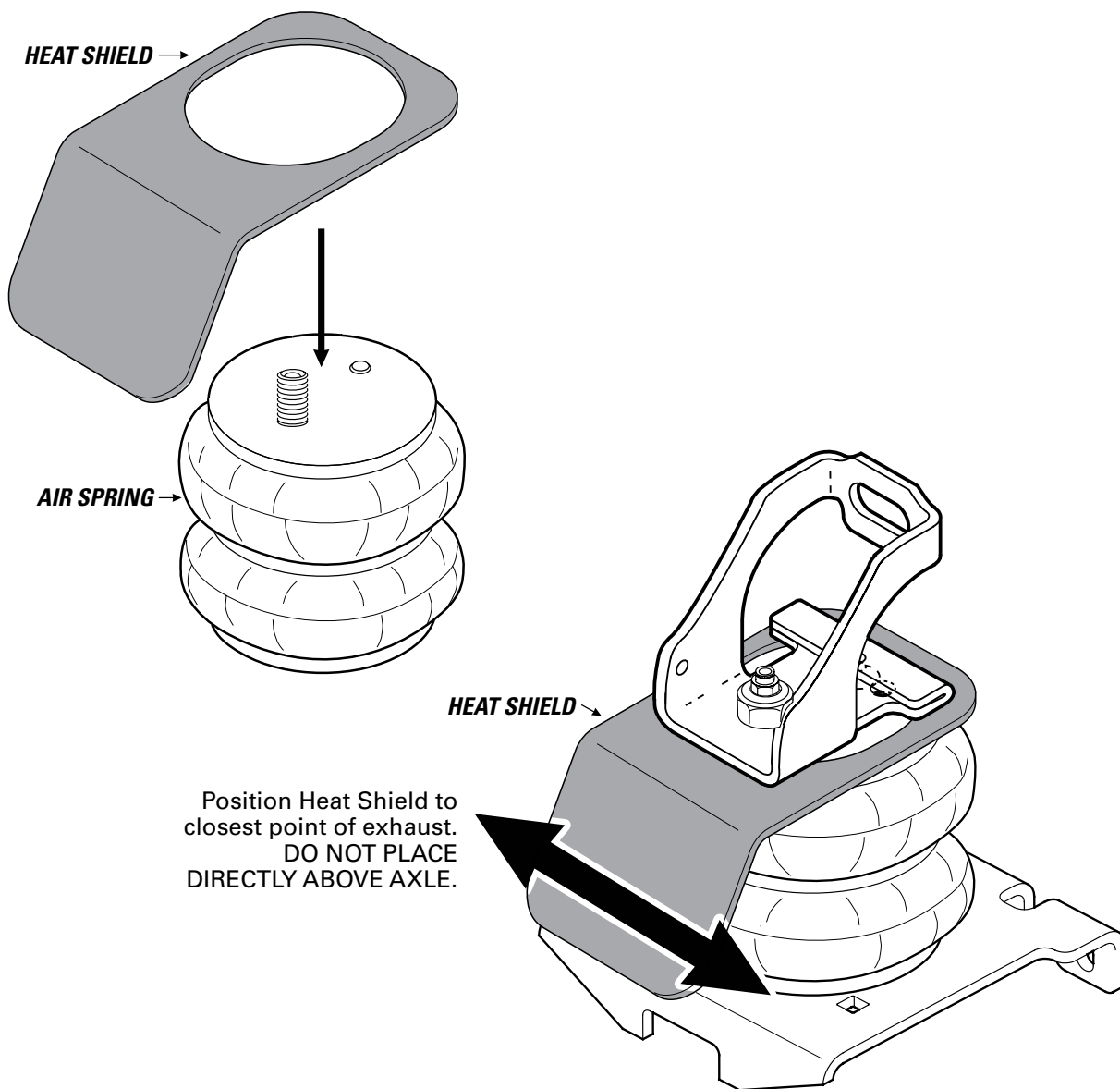

RIGHT SIDE INSTALLATION MUST INCLUDE HEAT SHIELD!







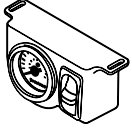
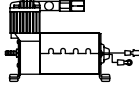
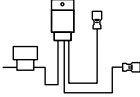

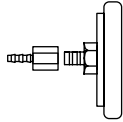

# SECTION 2 PARTS

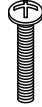
Compare the parts below to your kit. Assure you have all pieces, and organize them for an easier installation.

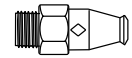
## AIR ACCESSORY CONTENTS

PART # 2572	 x1 SINGLE AIR CONTROL PANEL	 x1 AIR COMPRESSOR	 x1 RELAY HARNESS
PART # 9416	 x1 AIR LINE TUBE (30 FEET)	 x1 AIR FILTER AND FITTING	

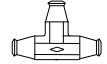
## AIR ACCESSORY HARDWARE PACK

PART # 3087	 x7 10-32 x 1" MACHINE SCREW	 x1 SMALL RING TERMINAL	 x1 1/8 NPT PUSH-TO-CONNECT STRAIGHT FITTING
PART # 3088	 x7 10-32 LOCK NUT	 x2 WIRE CONNECTOR	 x1 LARGE RING TERMINAL
PART # 3086	 x14 #10 FLAT WASHER	 x1 PUSH-TO-CONNECT T-FITTING	 x15 NYLON TIE

# CONTENTS AND OVERVIEW

## SECTION 2

PAGE **12** PLANNING THE INSTALL

PAGE **13** PREPARE AIR COMPRESSOR & CONTROL PANEL

PAGE **14** DRILL HOLES FOR AIR COMPRESSOR INSTALLATION

PAGE **15** INSTALL THE AIR COMPRESSOR

PAGE **16** AIR COMPRESSOR TO CONTROL PANEL AIR LINE TUBE

PAGE **17** AIR SPRINGS TO CONTROL PANEL AIR LINE TUBE

PAGE **18** INSTALL RELAY HARNESS

PAGE **19** FINISH CONTROL PANEL WIRING & INSTALLATION

PAGE **20** INSTALL THE AIR FILTER & CLEAN UP INSTALLATION

PAGE **21** TEST THE SYSTEM

PAGE **22** FIX AN AIR LEAK

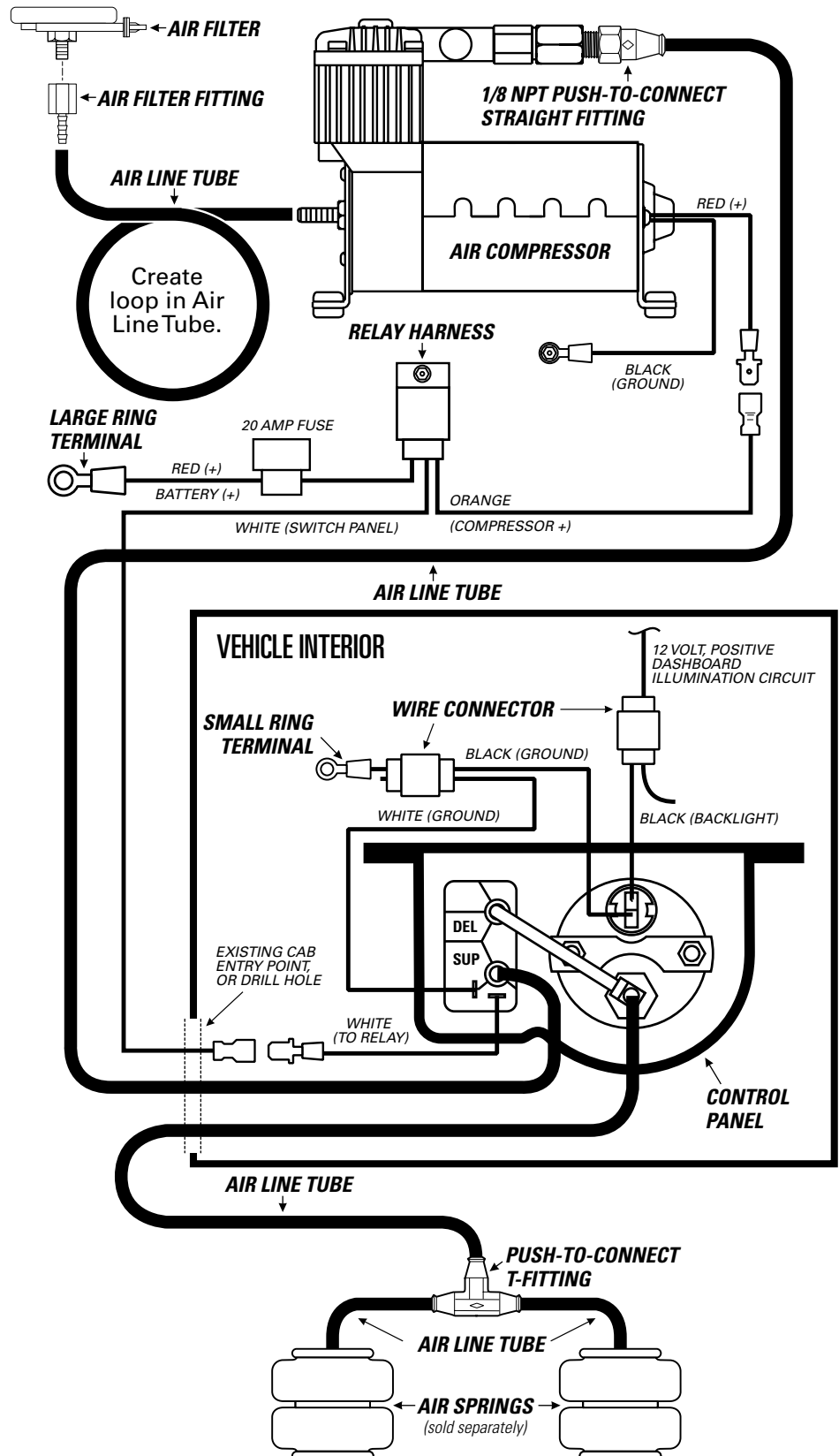

# PLANNING THE INSTALL

THESE PLANNING STEPS WILL HELP YOU SAVE TIME AND WILL MAKE THE INSTALLATION EASIER.

## **DETERMINE THE MOUNTING LOCATION FOR THE CONTROL PANEL**

- Mount inside the vehicle cab, in a place where you will not hit or kick it.
- Allow room for the Air Line Tube to run without sharp curves or bends.
- Do not obstruct your view or ability to safely operate the vehicle.

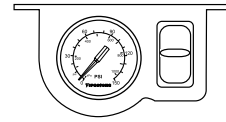

## **DETERMINE THE MOUNTING LOCATION FOR THE AIR COMPRESSOR**

- Provide ample air flow.
- Protect from airborne debris and moisture.
- If using the optional Frame Installation Kit (Part # 2497), consider the guidelines above, and follow Kit's instructions.

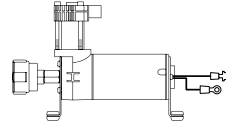

## **PLAN INSTALLATION ROUTES FOR WIRING AND AIR LINES INTO CAB**

- If possible, use existing factory grommet, such as where a wiring harness enters the cab.
- If not possible, drill a hole large enough for two Air Line Tubes and a ground wire. Make sure the wiring and Air Line Tubes are not exposed to sharp metal edges that can damage them.

## **SOAK AIR LINE TUBE ENDS IN HOT WATER BEFORE INSTALLING ONTO BARBED FITTINGS**

- The hot water makes the air line tube easier to work with and enables it to shrink onto the barbed fitting for a better seal.



## **TAPE ALL ELECTRICAL CONNECTIONS**

- Use electrical tape to appropriately secure and protect all electrical connections.

## **USING PUSH-TO-CONNECT FITTINGS FOR AIR LINES**

Your kit includes push-to-connect fittings to connect the Air Line Tubes to hardware. Use the instructions below when using the air line.

- 1** Insert end of Air Line Tube into Air Fitting.

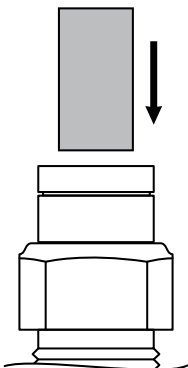

- 2** Push Air Line Tube into Air Fitting as far as possible.

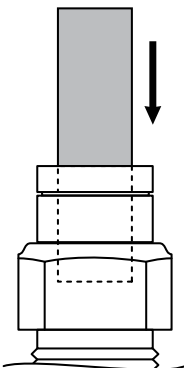

- 3** Gently pull on the Air Line Tube to check for a secure fit.

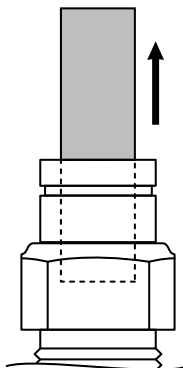

- 4** To remove, push down collar and gently pull Air Line Tube away.

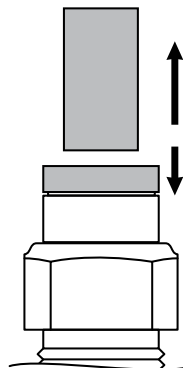

**Removal Tip:** Use a 1/4", 5/16", or 6mm open-ended wrench to push the collar down.

# 1

## PREPARE THE AIR COMPRESSOR

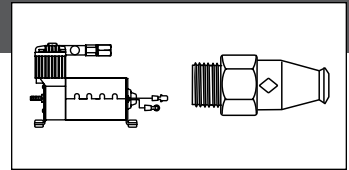

- 1 Install 1/8 NPT Push-to-Connect Straight Fitting to the head of the Air Compressor.

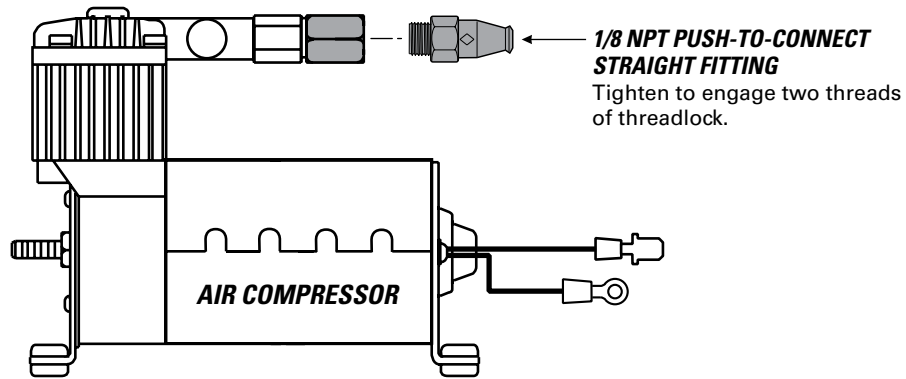

# 2

## DRILL HOLES FOR CONTROL PANEL INSTALLATION

Use the location you selected during the Planning the Installation step on Page 12.

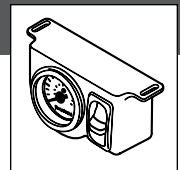

- 1 Using the Control Panel slots as a template, mark two drill locations with a punch or marking tool.
- 2 Drill a 3/16" diameter hole on each center mark.
- 3 Do not mount the Control Panel until Step 8.

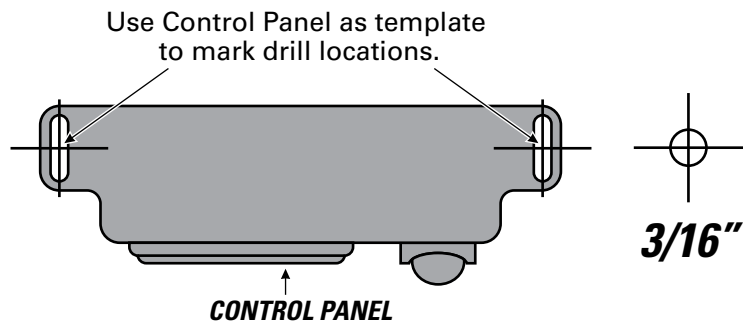

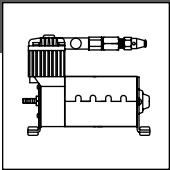

IF YOU ARE USING THE OPTIONAL FIRESTONE AIR COMPRESSOR MOUNTING KIT (PART # 2497), SKIP THIS STEP AND REFER TO THE MOUNTING KIT'S INSTRUCTIONS.



CHECK SURROUNDING AREA AND BACK SIDE OF MOUNTING LOCATION TO AVOID DRILLING INTO EXISTING LINES OR WIRING.

**1** Using the Air Compressor as a template, mark four drill locations with a punch or marking tool.

**2** Mark ground wire fastening location within reach of the ground wire Ring Terminal.

**3** Drill 3/16" diameter holes. Remove any burrs and debris from drill holes.

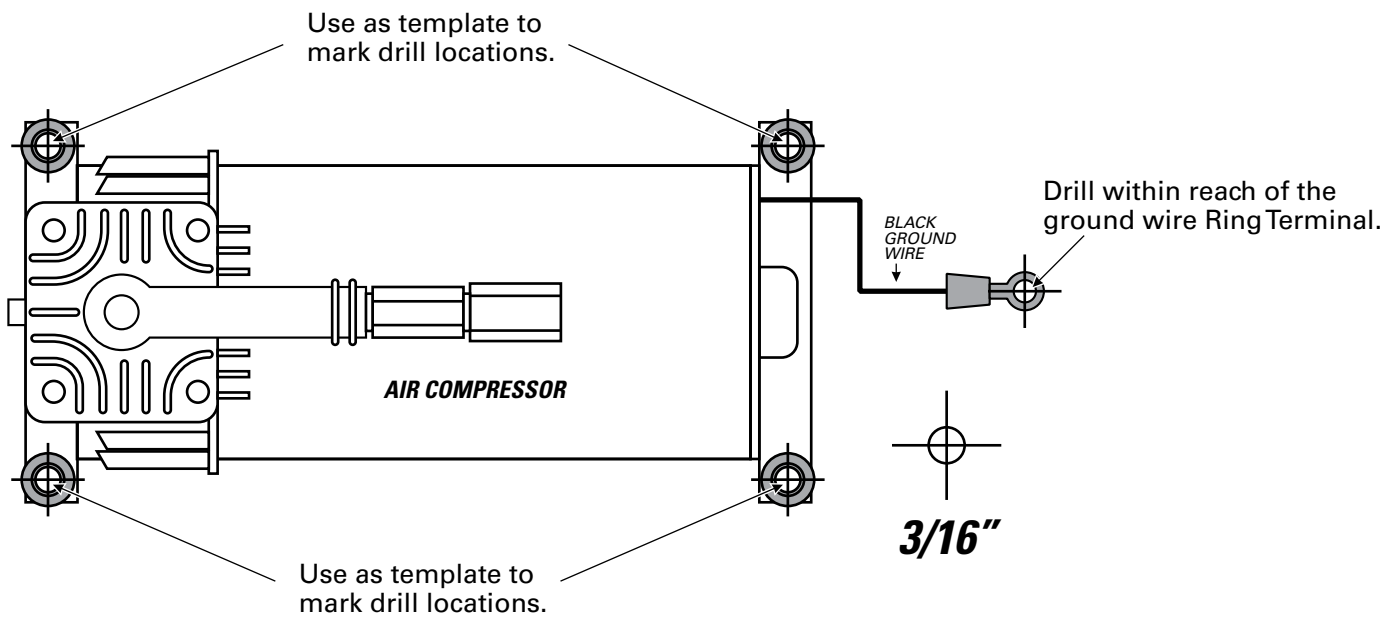

# 4

## INSTALL AIR COMPRESSOR



x 5



x 10



x 5



DO NOT OVER TIGHTEN MOUNTING BOLTS AND NUTS. TOO MUCH TORQUE CAN CRUSH THE BRASS INSERTS AND RUBBER ISOLATORS.

**1** Mount the Air Compressor to the drill hole location using the supplied fasteners. DO NOT OVERTIGHTEN.

**2** Mount the black ground wire Ring Terminal using the supplied fasteners. Assure that the Ring Terminal makes a solid contact with bare metal for a proper ground. (Optionally, you can run the negative to the negative battery terminal.)

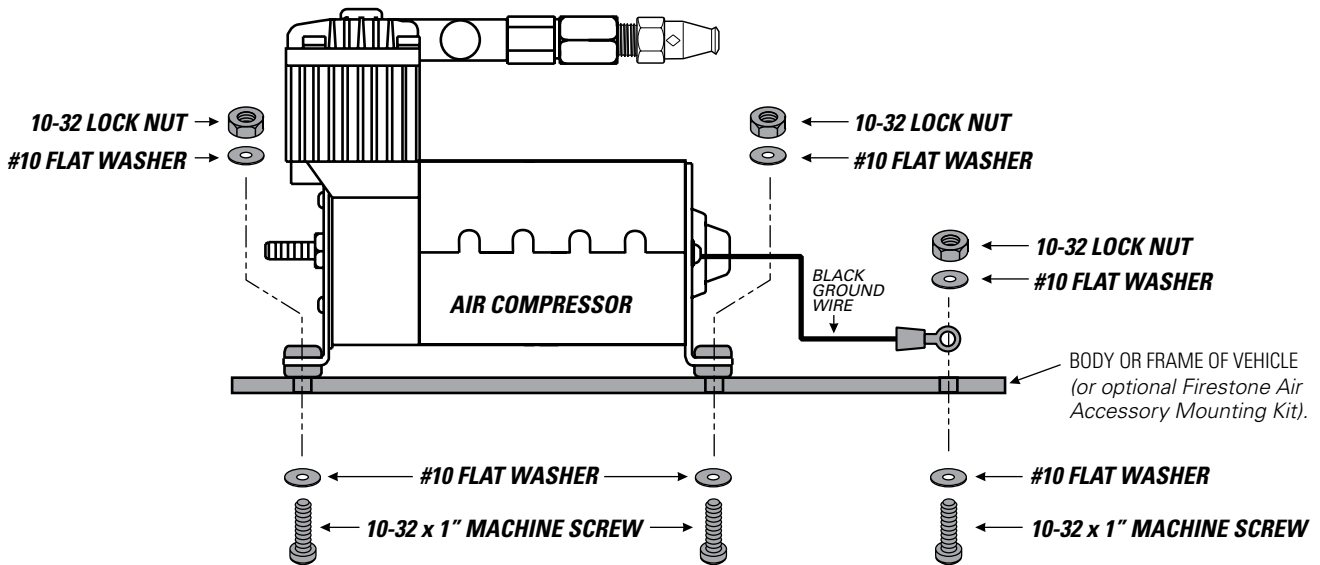

TO CREATE A PROPER GROUND, ASSURE THE GROUND RING TERMINAL CONTACTS BARE METAL AND IS FASTENED SECURELY. AFTER INSTALLATION, YOU MAY OPTIONALLY COAT THE RING TERMINAL IN SILICONE TO PROTECT IT FROM CORRODING.



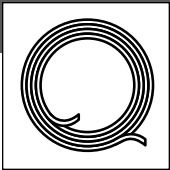

Use the route you selected during the Planning the Installation step on Page 12.

**1** Route the Air Line Tube from the Air Compressor to the Control Panel, leaving room to secure line safely. Use guidelines below to cut.



EXHAUST ALL AIR FROM THE SYSTEM PRIOR TO RELEASING AIR TUBES FROM AIR FITTINGS.

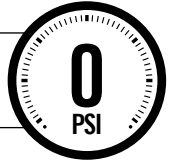

**2** Install the Air Line Tube end onto the barbed fitting on the back of the Control Panel switch as shown.



FOR PROPER INSTALLATION, SOAK AIR LINE TUBE ENDS IN HOT WATER BEFORE INSTALLING ONTO BARBED FITTINGS.

**3** Install the Air Line Tube end into the 1/8 NPT Push-to-Connect Straight Fitting on the top of the Air Compressor.

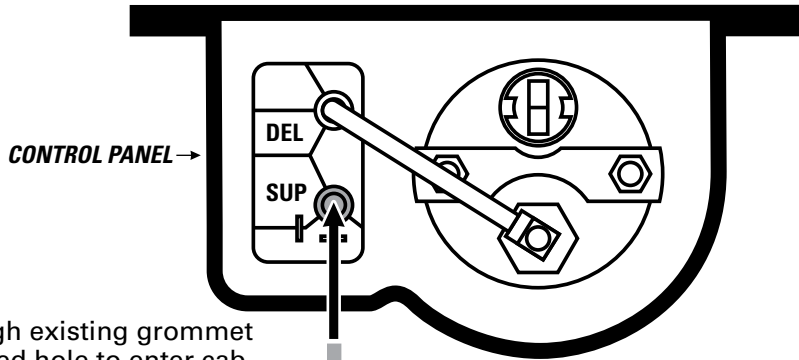

Pass through existing grommet or drilled hole to enter cab.

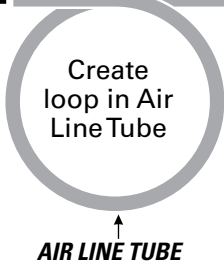
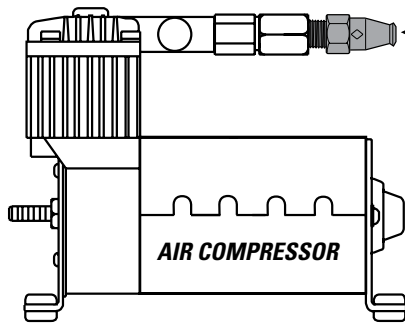

THE AIR LOOP CREATES A TRAP FOR CONDENSATION TO GATHER. WITHOUT THIS TRAP, THE AIR COMPRESSOR COULD BE DAMAGED BY WATER INTAKE.

**DO**

Make sure the cut is as square as possible. Use a tube cutter or sharp utility knife.

**DON'T**

Fold or kink the Air Line Tube. Cut the Air Line Tube at an angle. Use pliers, scissors, snips, saws, or side cutters.

**PROPER AND IMPROPER CUTS IN THE AIR LINE TUBE**

--	--	--	--

# 6

## INSTALL T-FITTING AND ROUTE AIR LINE TUBE TO CONTROL PANEL

Use the route you selected during the Planning the Installation step on Page 12.

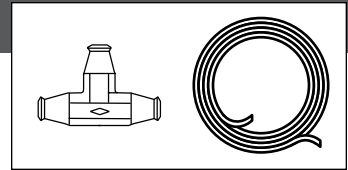

EXHAUST ALL AIR FROM THE SYSTEM PRIOR TO RELEASING AIR TUBES FROM AIR FITTINGS.

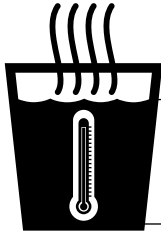
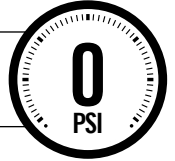

FOR PROPER INSTALLATION, SOAK AIR LINE TUBE ENDS IN HOT WATER BEFORE INSTALLING ONTO BARBED FITTINGS.

**1** Route the Air Line Tube from the Control Panel to the Air Springs.

**2** Install the Air Line Tube end onto the barbed fitting on the back of the Control Panel pressure gauge as shown.

**3** Determine a safe location for the Push-to-Connect T-fitting, where Air Line Tubes from the Air Springs and the Control Panel can safely meet.

**4** Install the Air Line Tubes from the Air Springs into opposite ends on the Push-to-Connect T-fitting, as shown.

**5** Install the Air Line Tube from the Control Panel to the single end on the Push-to-Connect T-fitting.

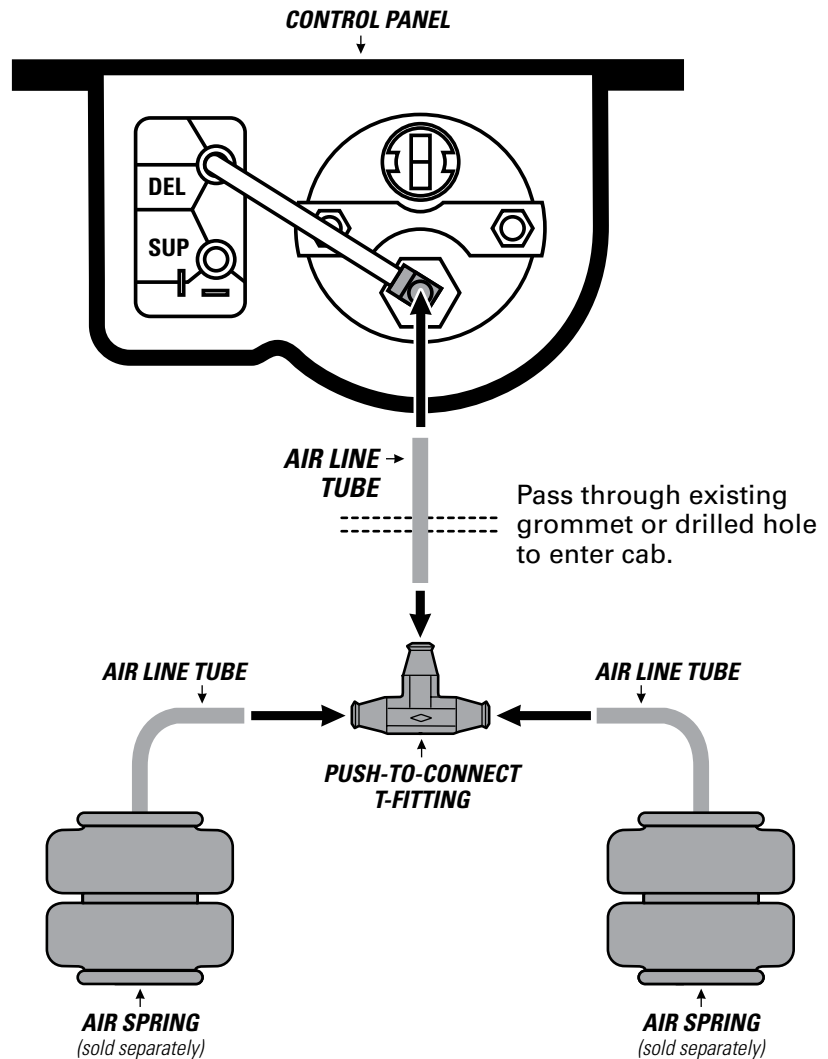

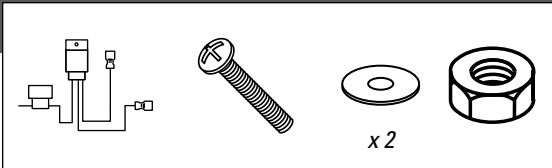

**1** Select a safe location within 3 feet of the Air Compressor.

**2** Mark and drill a 3/16" hole to mount the relay housing on the Relay Harness. Secure with fasteners shown.

**3** Route the white wire with the female spade connector labeled "switch panel" to the Control Panel.

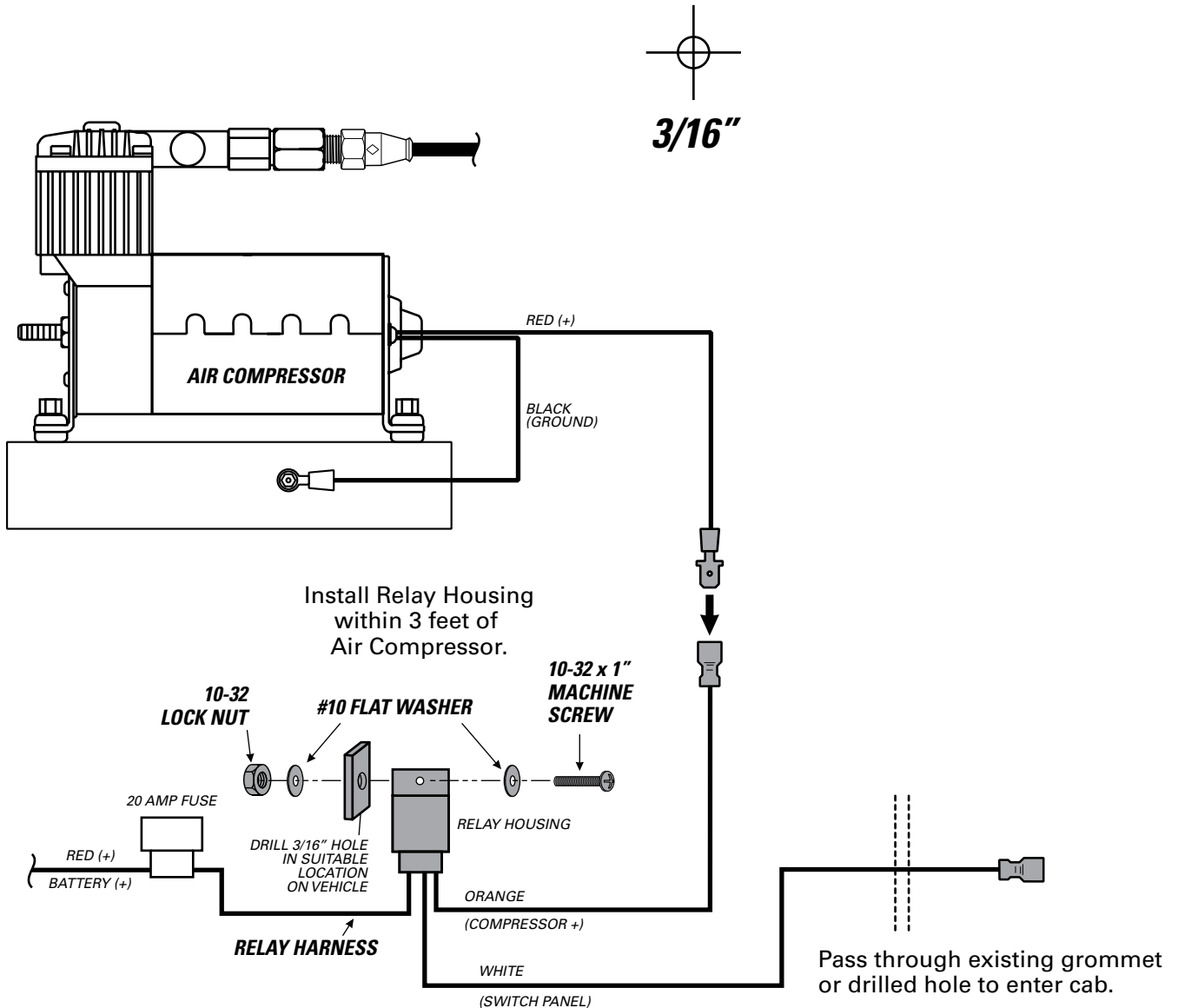

# 8

## FINISH WIRING AND INSTALLATION



x 2



x 3



x 6



x 3

**1** Connect wires, install Ring Terminals and Wire Connectors as shown below.

**2** Fasten Control Panel ground wires to vehicle as shown.

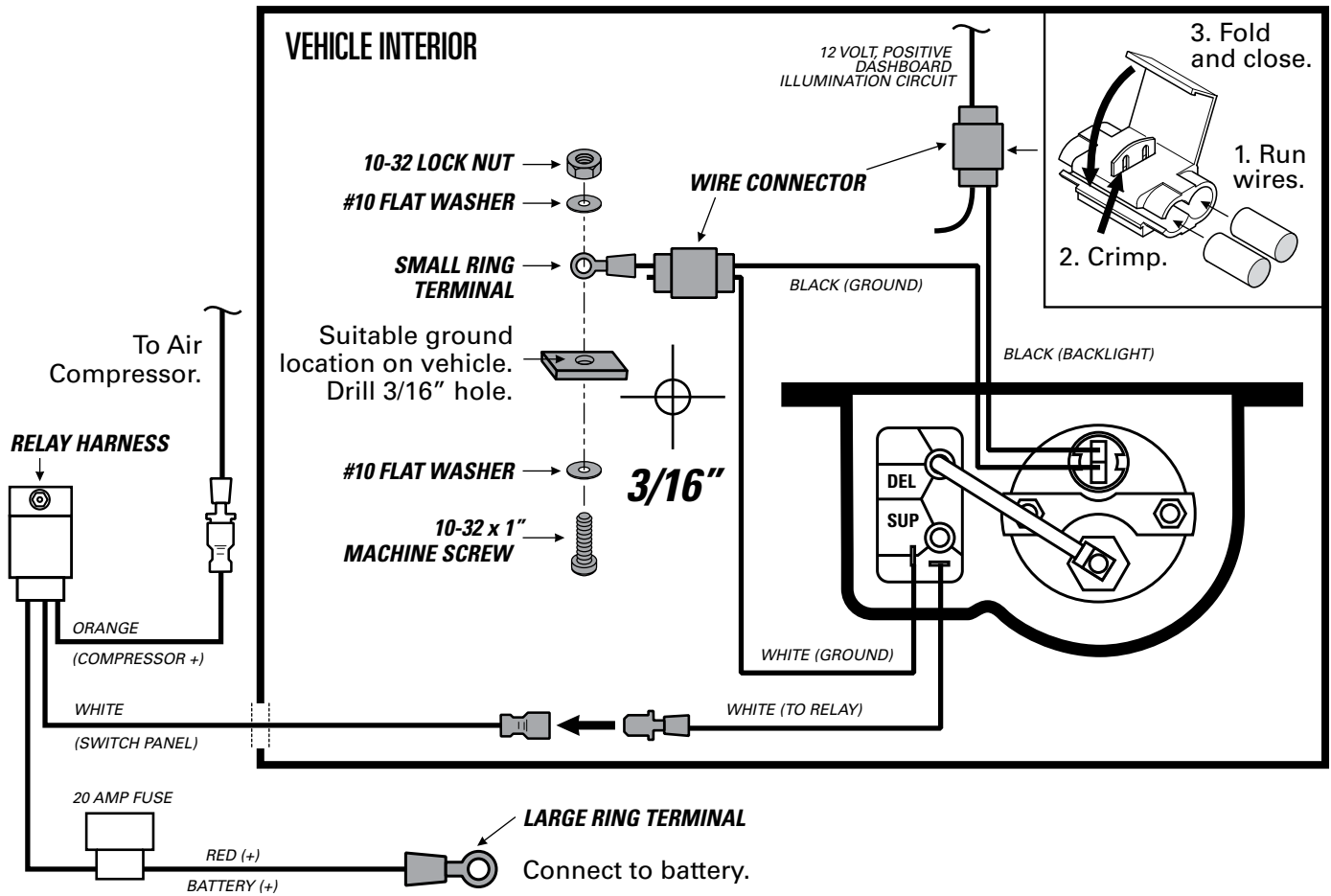

**3** Install the Control Panel using the supplied fasteners.

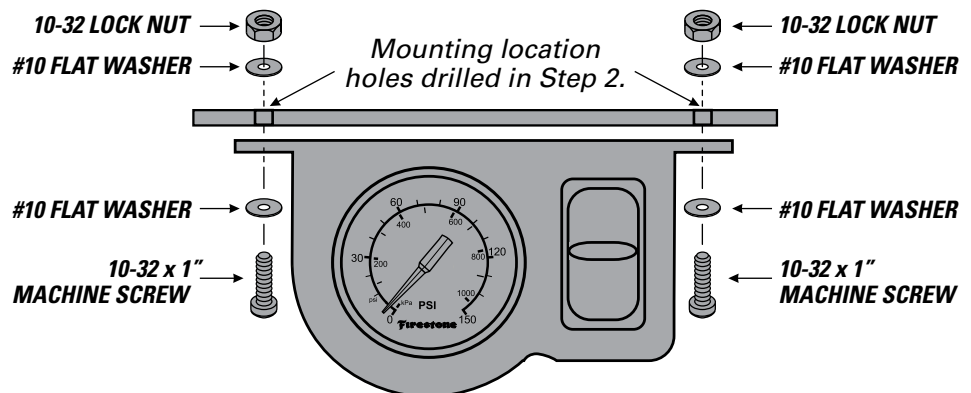

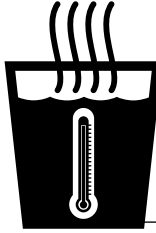
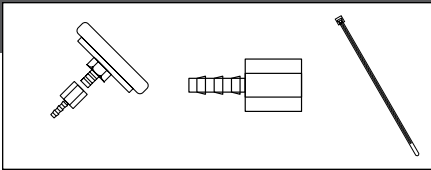

FOR PROPER INSTALLATION, SOAK AIR LINE TUBE ENDS IN HOT WATER BEFORE INSTALLING ONTO BARBED FITTINGS.

**1** Install the 1/4 NPT x 1/4" Tube Fitting onto the Air Filter Inlet as shown, hand tighten.

**2** Use supplied Nylon Ties to secure the Air Filter to a dry, protected location no more than 6 feet from the Air Compressor.

**3** Cut a length of Air Line Tube to run from the Air Compressor to the Air Filter. Attach the Air Line Tube to the barbed fittings as shown below.

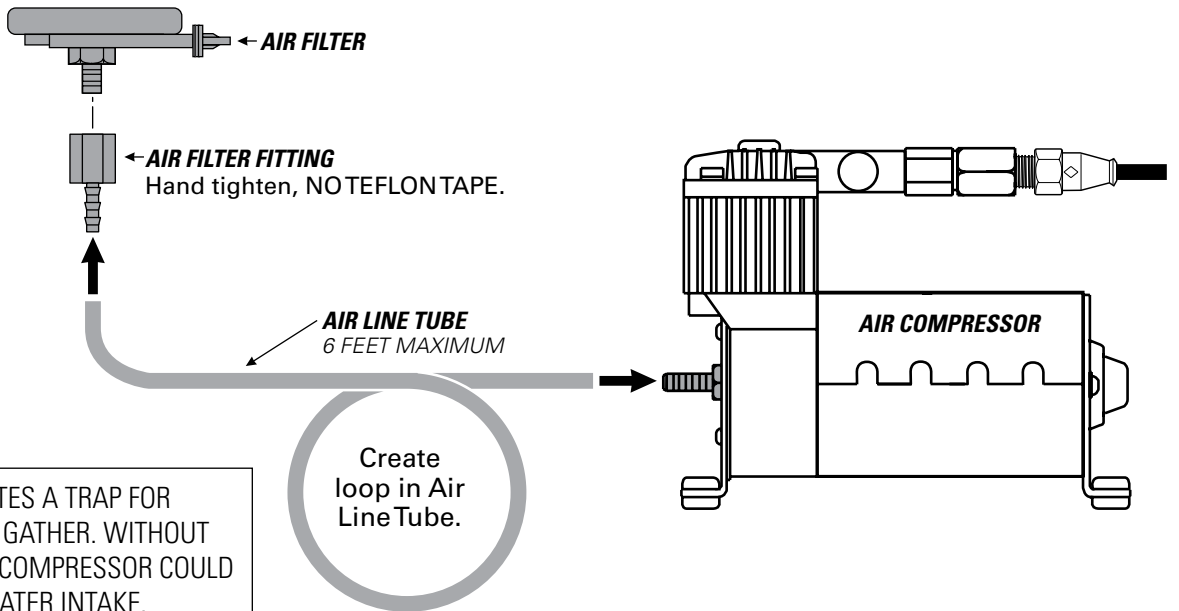

THE AIR LOOP CREATES A TRAP FOR CONDENSATION TO GATHER. WITHOUT THIS TRAP, THE AIR COMPRESSOR COULD BE DAMAGED BY WATER INTAKE.

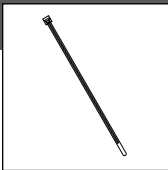
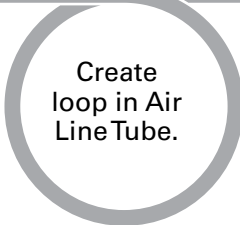

**1** Clean up the installation using supplied Nylon Ties, and return all factory parts and materials to operative state.



USING SUPPLIED NYLON TIES, SECURE ALL WIRING AND AIR LINE TUBE IN A MANNER THAT DOES NOT OBSTRUCT YOUR VIEW OR ABILITY TO SAFELY OPERATE THE VEHICLE.

# 10

## TEST THE SYSTEM

With the Air Command Kit and your Air Springs installed, you are ready to test the system.

- 1** Re-attach the negative battery cable.

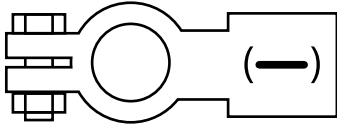

- 2** Turn on your vehicle's ignition.

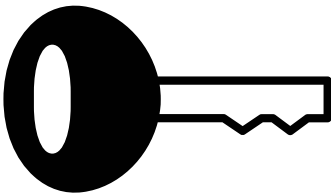

- 3** Push paddle switch up to inflate the Air Springs to 70 PSI.

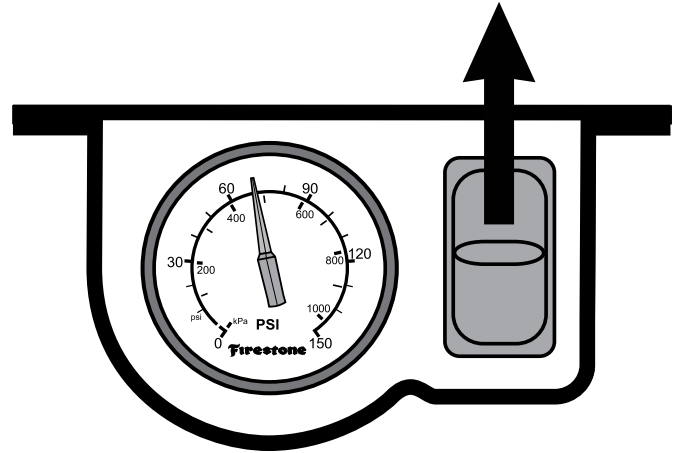

- 4** Spray fittings with soap and water mixture.



- 5** Observe bubbles.

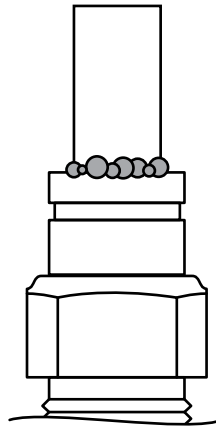

**SMALL SOAP BUBBLES  
THAT DO NOT EXPAND**

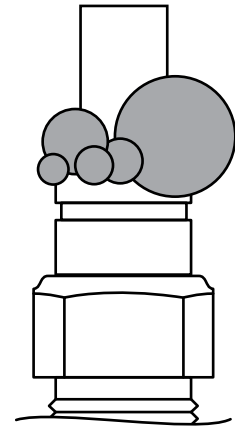

**SOAP BUBBLES  
THAT EXPAND**



# NO LEAKS?

Congratulations! You're riding right with the flip of a switch! Remember to review the Operating Instructions.

# LEAK?

Bummer. Continue to Step 11 to fix the leak.



EXHAUST ALL AIR FROM THE SYSTEM PRIOR TO RELEASING AIR TUBES FROM AIR FITTINGS.



- 1** Push paddle switch down to release all air pressure from the Air Springs.

NOTE: While doing this, if you get a quick burst of air prior to the gauge dropping to 0 PSI, your lines are incorrectly swapped.

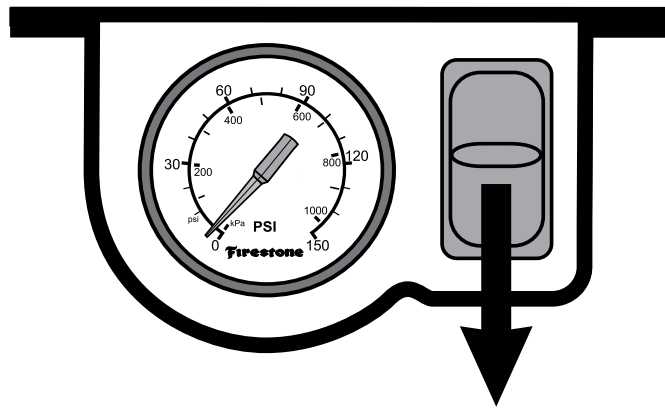

#### LEAK AT AIR LINE TUBE AND AIR FITTING

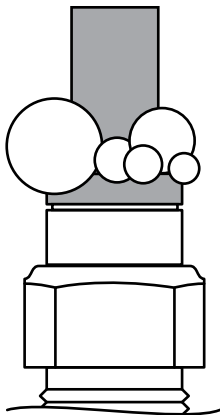

Release Air Line Tube (see page 12). Review proper cuts and procedures in Step 5. Repeat installation steps.

#### LEAK AT BASE OF AIR FITTING ON AIR SPRING

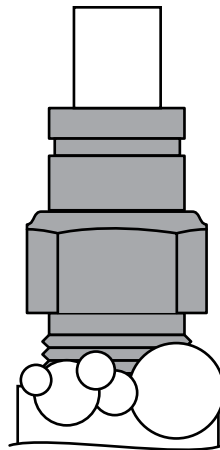

Tighten Air Fitting one turn or until leak stops.

#### LEAK AT A BARBED FITTING

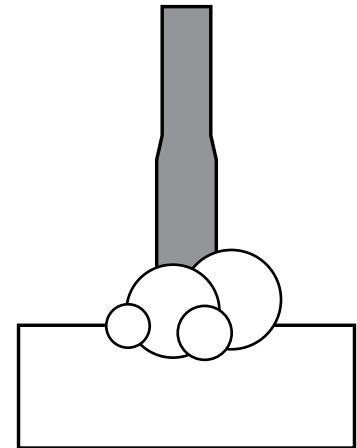

Being careful not to scar the metal barbs, cut away, check for debris. Trim Air Tube Line, **soak for 5 minutes in hot water**. Reinstall.

## STILL HAVE A LEAK?

Refer to the Troubleshooting section of the Instruction Manual. If the leak persists, or if there is an issue with a leaking part, call 1-800-888-0650; Option 1; Option 1 for Tech Support.



[riderite.com](http://riderite.com)

### **SAFELY RETURN VEHICLE TO OPERATIVE STATE**

If you removed any wheels during installation, install the wheels and torque the lug nuts to the manufacturer's specifications. Safely remove any jack stands and wheel chocks used during installation. Re-attach the negative battery cable.

### **READ AND UNDERSTAND THE OPERATING INSTRUCTIONS**

The Ride-Rite system can improve handling and comfort. Take the time to learn how to properly use and maintain your investment by reading the Operating Instructions.

### **BEFORE YOU DRIVE, CONFIRM THE FOLLOWING:**

- Do you have a minimum of 5PSI in your Air Springs?
- Are your Air Springs standing 5 1/2" - 7" tall? 5 1/2" - 7"
- Are your Air Springs properly aligned, left-to-right and front-to-back?
- Are your nuts and bolts tight?
- Put your paper work back into the sleeve and keep it in your glove compartment for future reference.
- Secure all Air Line Tubes and wiring inside the cab and on the outside of the truck.
- The system passes the leak test and holds air.
- The Air Compressor ground ring terminal is contacting bare metal, and coated with silicone if possible.
- Make sure no wiring, Air Line Tubes, or hardware obstruct your vision or ability to safely operate the vehicle.
- There is a loop in the Air Line Tubes as shown to prevent water or debris from getting into the Air Compressor head and damaging it.
- The air gauge backlight turns off when the ignition is off, or when dashboard lights do not illuminate.
- You've been bagged...and now your suspension is Airide equipped! Show it off with the supplied decal!

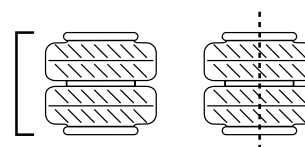

## **NEED INSTALLATION HELP? 1-800-888-0650**

Select Option 1 for Ride-Rite; Select Option 1 for Technical Support.

Or, email us at [rrtech@fsip.com](mailto:rrtech@fsip.com). If emailing, please include photos to help us better diagnose and understand any problems you may be experiencing.



CONNECT WITH US



@rideriteair



@rideriteair



Firestone RideRite



Firestone Ride-Rite