



2003-2005 Ford Powerstroke BD Remote Mount Exhaust Brake

Part Number	Application
1027145	Ford 6.0L Powerstroke with 3.5" Exhaust (Manual Trans)
1027145AP	Ford 6.0L Powerstroke with 3.5" Exhaust (Auto Trans)
1027146	Ford 6.0L Powerstroke with 4.0" Exhaust (Manual Trans)
1027146AP	Ford 6.0L Powerstroke with 4.0" Exhaust (Auto Trans)

Serial # _____

Date Purchased _____

Purchased from _____

Installed by _____

*** Please fill out and mail registration card as soon as possible. ***

OWNER'S MANUAL – LEAVE IN GLOVE BOX

BD ENGINE BRAKE, INC.
 Plant Address: A10-33733 King Rd, Abbotsford, BC, Canada V2S 7M9
 US Shipping Address: 88-446 Harrison St, Sumas, WA 98295 US Mailing Address: PO Box 231, Sumas, WA 98295
 Phone: 604-853-6096 Fax: 604-853-8749 Internet: www.bd-power.com

TABLE OF CONTENTS

Kit Contents.....	3
Welcome	4
Options	4
Battery Disconnect & Removal.....	5
Vacuum Pump & Reservoir Removal.....	5
Air Compressor & Reservoir Installation	6
Regulator Installation.....	6
Valve Installation	7
Air Solenoid Installation.....	8
Pump Relay Harness and Under hood Wiring	9
Cab Wiring.....	12
Optional Shifter Switch	15
PCM Wiring	16
Cruise Control Wiring	17
Control Wiring.....	18
Battery Reinstall	18
Brake Controller Calibration	18
Exhaust Brake Testing	19
Maintenance & Troubleshooting.....	20
Common Problems.....	20
Exhaust Brake Adjustments	21
Operating Guidelines.....	21
LIMITED WARRANTY STATEMENT.....	24

BD ENGINE BRAKE, INC.

Plant Address: A10-33733 King Rd, Abbotsford, BC, Canada V2S 7M9

US Shipping Address: 88-446 Harrison St, Sumas, WA 98295 US Mailing Address: PO Box 231, Sumas, WA 98295

Phone: 604-853-6096 Fax: 604-853-8749 Internet: www.bd-power.com

Kit Contents

Base Kit

All kits receive these parts – see below for the separate items for each kit.

1	1030125	Air Pump Kit (w/ mounting bracket)
1	1030124	Vacuum Pump Relocation kit
1	1330440	Vacuum Pump/Relay wiring harness
1	1127038	Exhaust Brake
1	1220047	Regulator Assembly
1	1220048	Solenoid Assembly
1	1220113	Air Snorkel Kit
1	1331045	Control Kit
2	1100350	3.5" Pipe Adapter
2	1100404	4.0" Marmon clamp
1	1100735	3.5" Lap Exhaust Clamp
1	1321045	Application Kit (w/ brake module)

Additional Kit Components – 1027145

2	1100350	3.5" Pipe Adapter
2	1100404	4.0" Marmon clamp
1	1100735	3.5" Lap Exhaust Clamp

Additional Kit Components – 1027146

2	1100400	4.0" Pipe Adapter
2	1100404	4.0" Marmon clamp
1	1100740	4.0" Lap Exhaust Clamp

Additional Kit Components – 1027145AP

2	1100350	3.5" Pipe Adapter
2	1100404	4.0" Marmon clamp
1	1100735	3.5" Lap Exhaust Clamp
1	1031300	Ford 6.0L Auto/PressureLoc

Additional Kit Components – 1027146AP

2	1100400	4.0" Pipe Adapter
2	1100404	4.0" Marmon clamp
1	1100740	4.0" Lap Exhaust Clamp
1	1031300	Ford 6.0L Auto/PressureLoc

BD ENGINE BRAKE, INC.

Plant Address: A10-33733 King Rd, Abbotsford, BC, Canada V2S 7M9

US Shipping Address: 88-446 Harrison St, Sumas, WA 98295 US Mailing Address: PO Box 231, Sumas, WA 98295

Phone: 604-853-6096 Fax: 604-853-8749 Internet: www.bd-power.com

Welcome

Thank you for purchasing a BD Engine Exhaust Brake. Your kit should have the above-mentioned items for your installation; please check to make sure that you have everything. This manual is to aid you with your installation and operation of your braking unit. We strongly suggest that you fill out the installation information and retain this manual for any future reference.

Options

Description	Part #
Manual Transmission Shifter Switch Kit	1300210
Transmission Gauge Kit (Auto Trans)	1030584
X Monitor (3 in 1 Digital Gauge)	1087210
Performance Torque Convertor	Call

Attention:

On vehicles with automatic transmissions it is absolutely necessary to install a 6.0L AutoLoc/PressureLoc (#1031300) to utilize the full performance of the BD exhaust brake.

BD ENGINE BRAKE, INC.

Plant Address: A10-33733 King Rd, Abbotsford, BC, Canada V2S 7M9

US Shipping Address: 88-446 Harrison St, Sumas, WA 98295 US Mailing Address: PO Box 231, Sumas, WA 98295

Phone: 604-853-6096 Fax: 604-853-8749 Internet: www.bd-power.com

Battery Disconnect & Removal

Disconnect the negative terminals on both of the vehicle's batteries, and then disconnect the positive terminals. Remove the passenger side battery.

Vacuum Pump & Reservoir Removal

Locate the small electric vacuum pump and reservoir on the passenger side fender well. Remove the reservoir by removing the bolts on the underside of the fender well, and disconnecting all air hoses. Remove the small electric vacuum pump by removing the screws, unplugging the electrical plug and pulling off the supply tube to the reservoir.

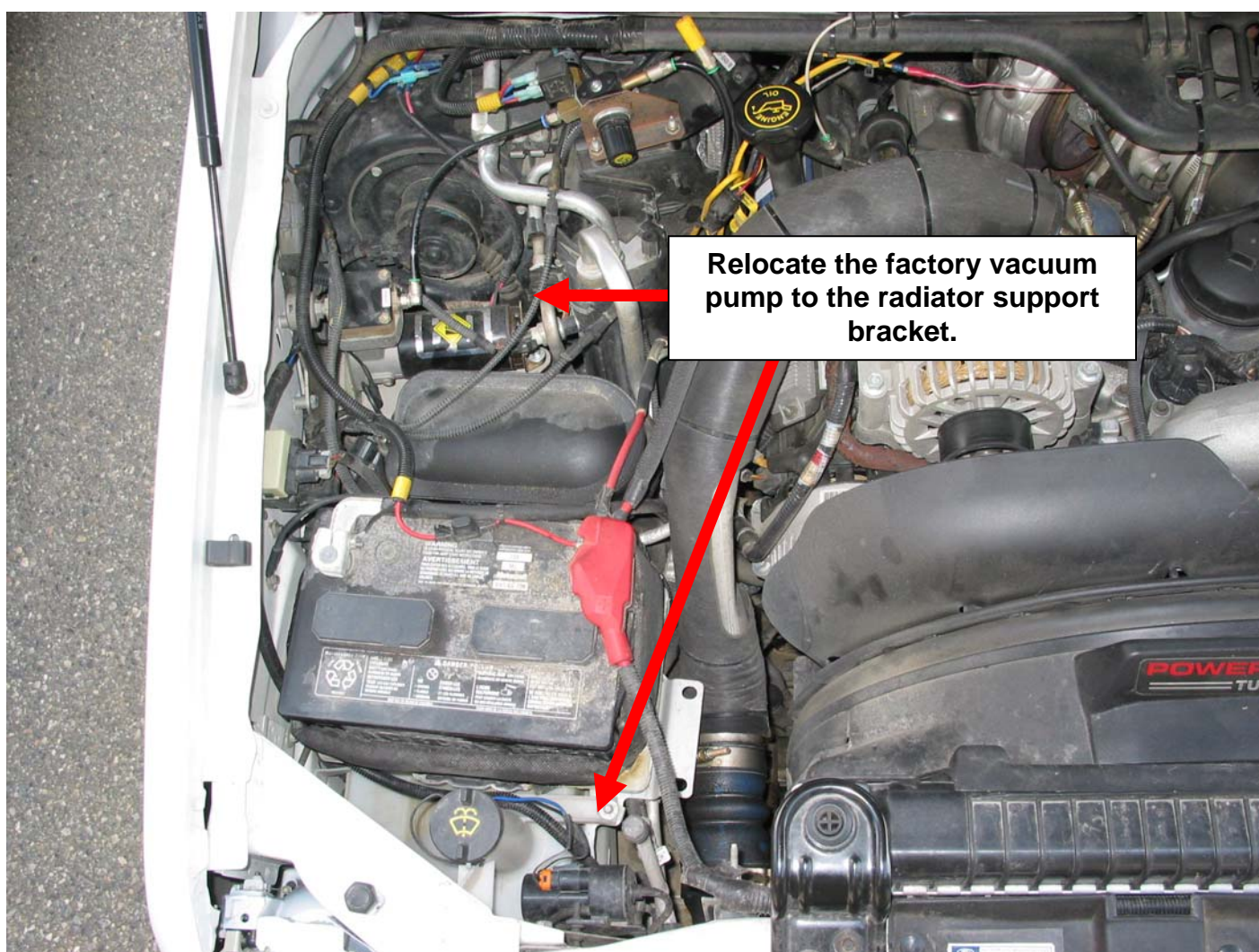

Remove the electric vacuum pump from the stock mount and re-install onto the new relocation mount provided. Trim the rubber ends on the three vibration dampers to clear when reinstalling. Install on the right hand side of the radiator support bracket with the two bolts and washers provided.

BD ENGINE BRAKE, INC.

Plant Address: A10-33733 King Rd, Abbotsford, BC, Canada V2S 7M9

US Shipping Address: 88-446 Harrison St, Sumas, WA 98295 US Mailing Address: PO Box 231, Sumas, WA 98295

Phone: 604-853-6096 Fax: 604-853-8749 Internet: www.bd-power.com

Cut the power supply wires for the electric vacuum pump approximately 4" from the connector and splice in the black and blue wires supplied using the butt connectors and shrink tubing. Route the relocation loom along the fender and towards the front up to the new vacuum pump location. Inside of the loom should be the supplied black and blue wires, along with the 1/8" plastic vacuum tube. Shrink tubing as been provided to securely seal this connection.

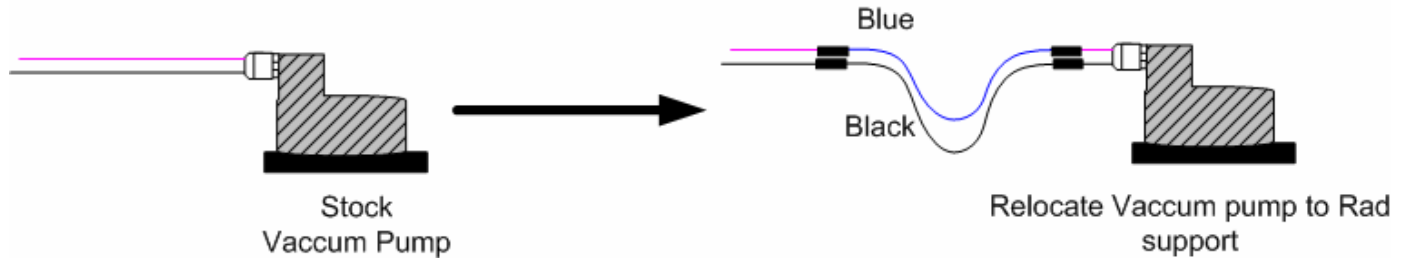

Air Compressor & Reservoir Installation

Install the supplied air compressor mounting bracket in the same location that the small electric vacuum pump was removed from. Secure it to the side of the engine compartment with supplied fender screws.

Install the BD Air Compressor onto the mounting bracket with the nuts supplied and reinstall the reservoir back into its original location. Once this has been completed, re-attach all air hoses.

You may now re-install the battery, but do not connect the positive or negative terminals at this time.

Regulator Installation

Install the Air Regulator assembly just above the AC dryer onto the MAP sensor bracket. You will need to remove two 10mm nuts to secure the regulator bracket to the mounting bolts. Install the bracket in a way that the regulator is easily adjusted and re-tighten the nuts to finish the installation. Install the relay wiring assembly on one of the existing screws or bolts and route the harness over to fender and secure. Make wire connections as per wiring diagram.

BD ENGINE BRAKE, INC.

Plant Address: A10-33733 King Rd, Abbotsford, BC, Canada V2S 7M9

US Shipping Address: 88-446 Harrison St, Sumas, WA 98295 US Mailing Address: PO Box 231, Sumas, WA 98295

Phone: 604-853-6096 Fax: 604-853-8749 Internet: www.bd-power.com

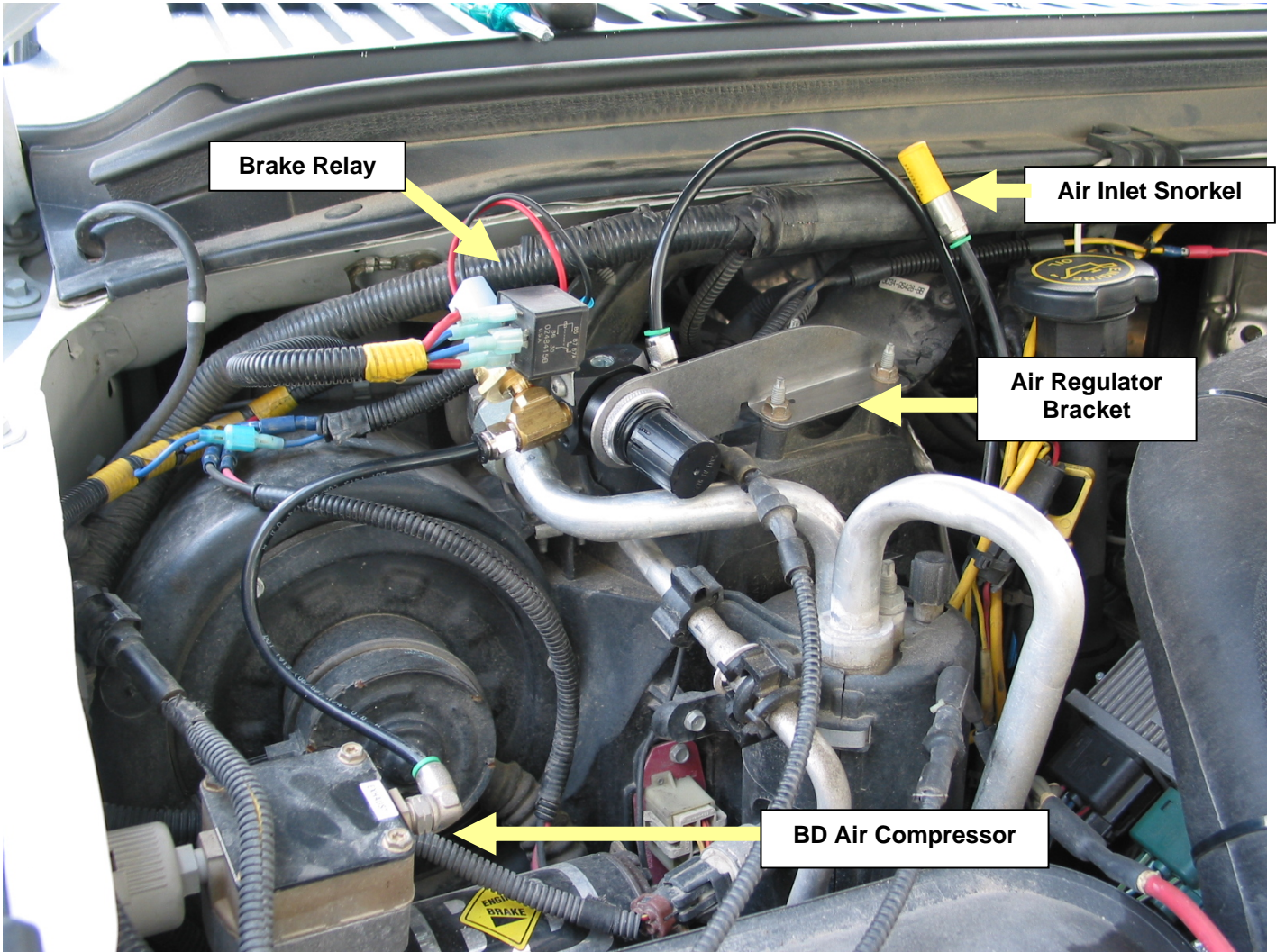

Valve Installation

***SAFETY*:** Raise the vehicle to a good working height and support with jack stands or axle stands to prevent injury or damage.

Locate the catalytic converter. About 8" from the rear of the catalytic converter you will need to remove an 11" section of the exhaust.

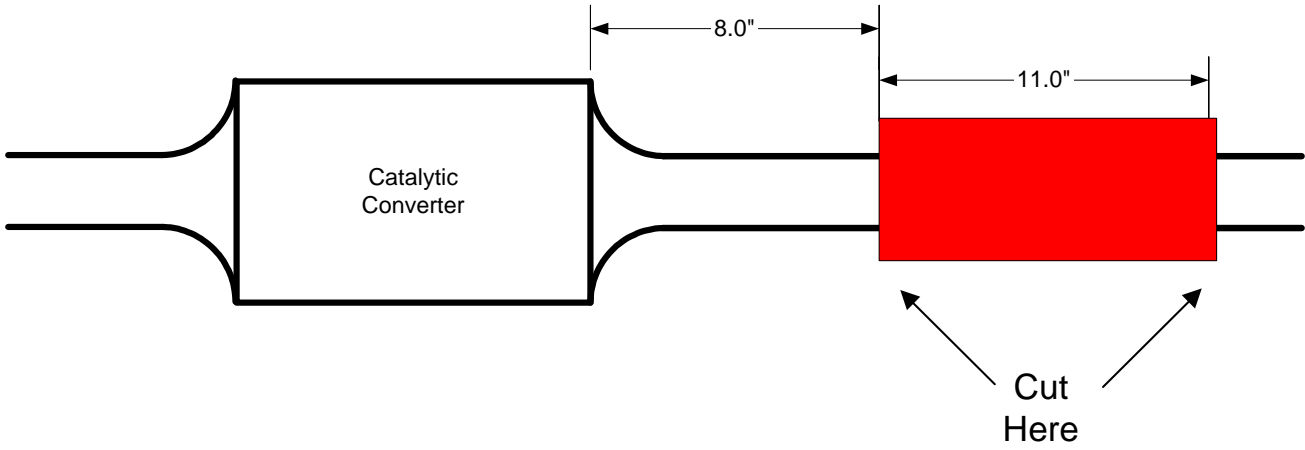

Slide the supplied flanges over the each side of the cut exhaust. The flange closest to the front of the vehicle will need to be welded. A good clean weld is needed to seal the high backpressure that the exhaust brake will create. The rear flange should be mounted with the supplied stainless band clamp.

Insert the valve assembly in between the two flanges and ensure that there is ample room when welding and tightening the two flanges. Also take note that there is an exhaust flow direction arrow cast into the exhaust brake. This arrow should be pointing **towards the rear of the vehicle**. Once you have finalized the fit by welding the front flange and securing the rear the flange, tighten the two supplied V clamps around both flanges on either side of the exhaust brake. The exhaust brake should now be held securely in place.

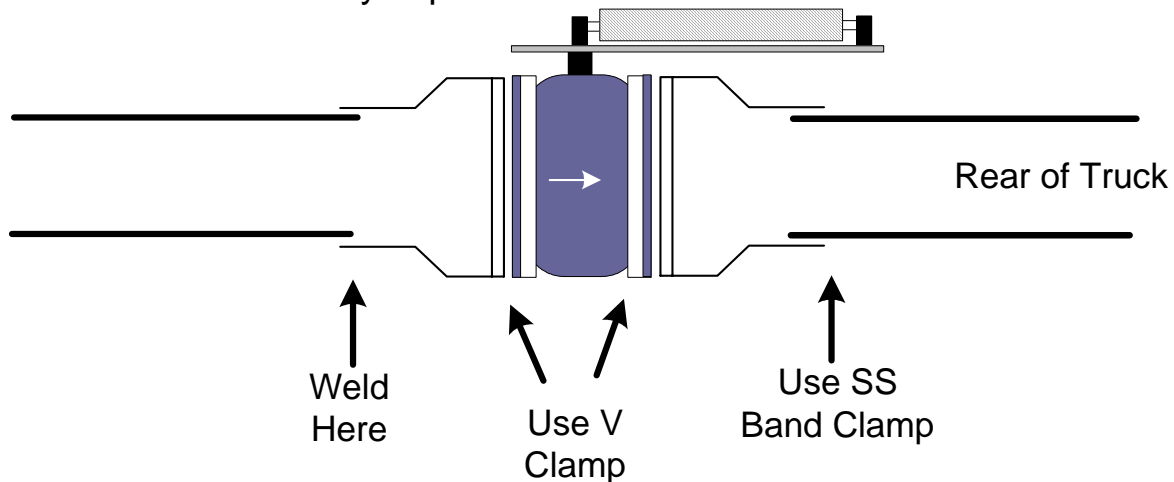

Note: This kit can be purchased for 4" exhaust or the factory 3.5" exhaust.

Air Solenoid Installation

Just across from the exhaust brake on the passenger side frame rail you will notice a number of factory holes in the frame. You will need to mount the air solenoid assembly on the inside of the frame rail utilizing one of these holes. Make sure that the air solenoid assembly is as close as possible to the exhaust brake to ensure a quick engagement and disengagement of the valve.

At the same time it is a good idea to install the feedback diode harness. Connect the

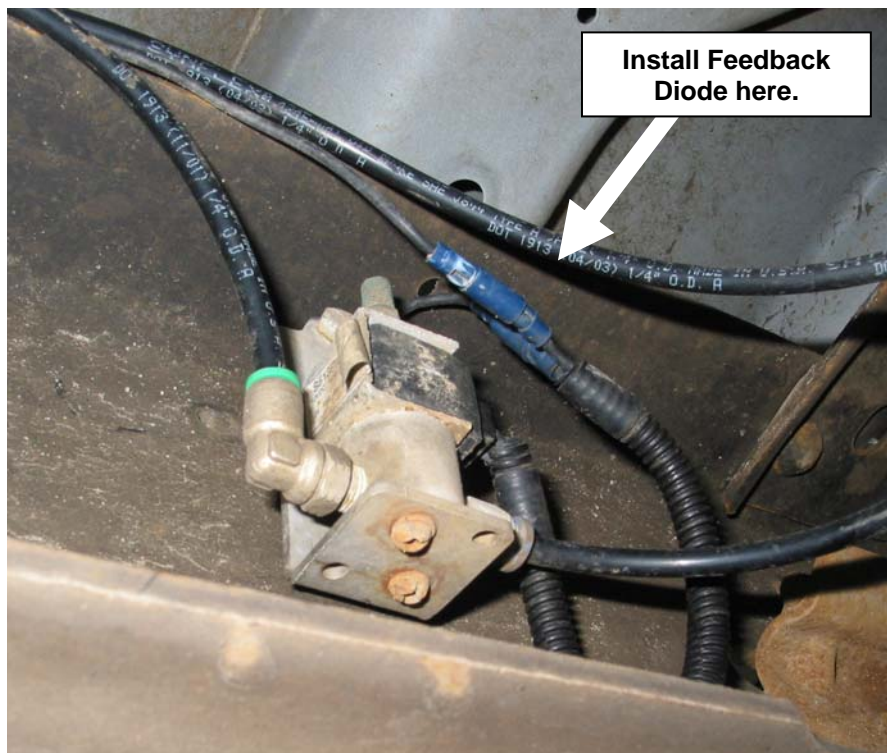

BD ENGINE BRAKE, INC.

Plant Address: A10-33733 King Rd, Abbotsford, BC, Canada V2S 7M9

US Shipping Address: 88-446 Harrison St, Sumas, WA 98295 US Mailing Address: PO Box 231, Sumas, WA 98295

Phone: 604-853-6096 Fax: 604-853-8749 Internet: www.bd-power.com

connectors together matching Black to Black (Ground) and Red to power.

Pump Relay Harness and Under hood Wiring

Consult the diagram on pages 10-12 for proper connections.

Starting first at the relay loom assembly, you'll need to connect both the positive and negative leads to the respective battery terminals (The battery leads should not be yet connected at this time).

Connect the male and female blue bullet connectors from the Relay loom assembly to the BD Air compressor leads.

Connect the male spade connector (blue wire) and the female bullet connector (blue wire) to the corresponding connectors (blue wire) on the small pressure switch loom.

Route the pressure switch loom near the top of the engine firewall. Connect the two female spade connectors (blue wires) to the pressure switch. Note that it does not matter which connection goes where.

Route and connect the ground eyelet to a bolt on the firewall that will provide a good solid ground.

Note: You do not need to connect the spare male bullet connector. It should be taped off.

Connect the female bullet connector to the long Air Solenoid loom assembly. This loom assembly will contain one black wire and two airlines. You will need to crimp the corresponding male bullet connector on this black wire, once you have routed the loom and trimmed the assembly to fit your specific application. You will need to route this loom assembly to Air Solenoid unit that you mounted on the frame rail across from the brake. Connect the female bullet connector to the red wire of the feedback diode assembly. The other red wire end of the feedback diode assembly should then be connected to the air solenoid. Connect the ground of the air solenoid to the black wire of the feedback diode assembly, and finally connect the remaining black wire to ground. Be sure that this connection is very tight. Sealing this connection with dielectric grease or shrink tubing is preferred.

It is highly recommended that you route this loom away from any moving parts or heat sources (i.e. exhaust). A good path is on the outside of the frame rail.

The next step is to connect all the airlines. Use a small piece of the provided plastic airline to make a connection between the pressure switch and the BD air compressor.

BD ENGINE BRAKE, INC.

Plant Address: A10-33733 King Rd, Abbotsford, BC, Canada V2S 7M9

US Shipping Address: 88-446 Harrison St, Sumas, WA 98295 US Mailing Address: PO Box 231, Sumas, WA 98295

Phone: 604-853-6096 Fax: 604-853-8749 Internet: www.bd-power.com

Connect the long airline to the 90° connector on the pressure regulator to the air solenoid mounted on the frame rail. You will need to connect this line to the input of the air solenoid. **"IN"** is marked on the input for easy reference.

Use a small section of line to connect the output of the air solenoid (90° fitting) to the input of the exhaust brake. The Air Cylinder has a quick release air valve attached to the top of it.

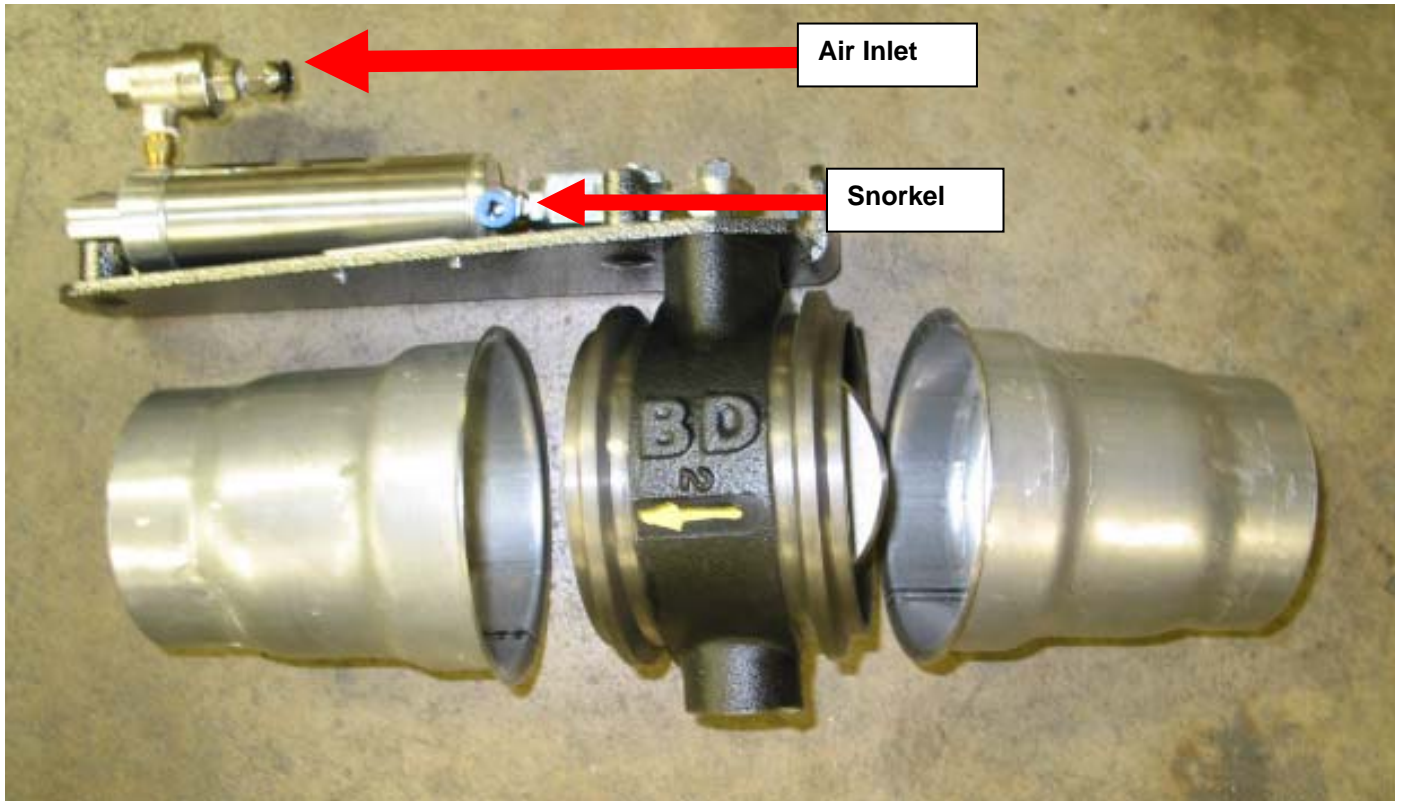

You must next run the snorkel line from the exhaust brake cylinder to underneath the hood of the vehicle in a dry clean area. You should see this connection on the front end of the exhaust brake air cylinder.

BD ENGINE BRAKE, INC.

Plant Address: A10-33733 King Rd, Abbotsford, BC, Canada V2S 7M9

US Shipping Address: 88-446 Harrison St, Sumas, WA 98295 US Mailing Address: PO Box 231, Sumas, WA 98295

Phone: 604-853-6096 Fax: 604-853-8749 Internet: www.bd-power.com

Ford 6.0L Exhaust Brake P/N#1027145 / 1027146 / AP

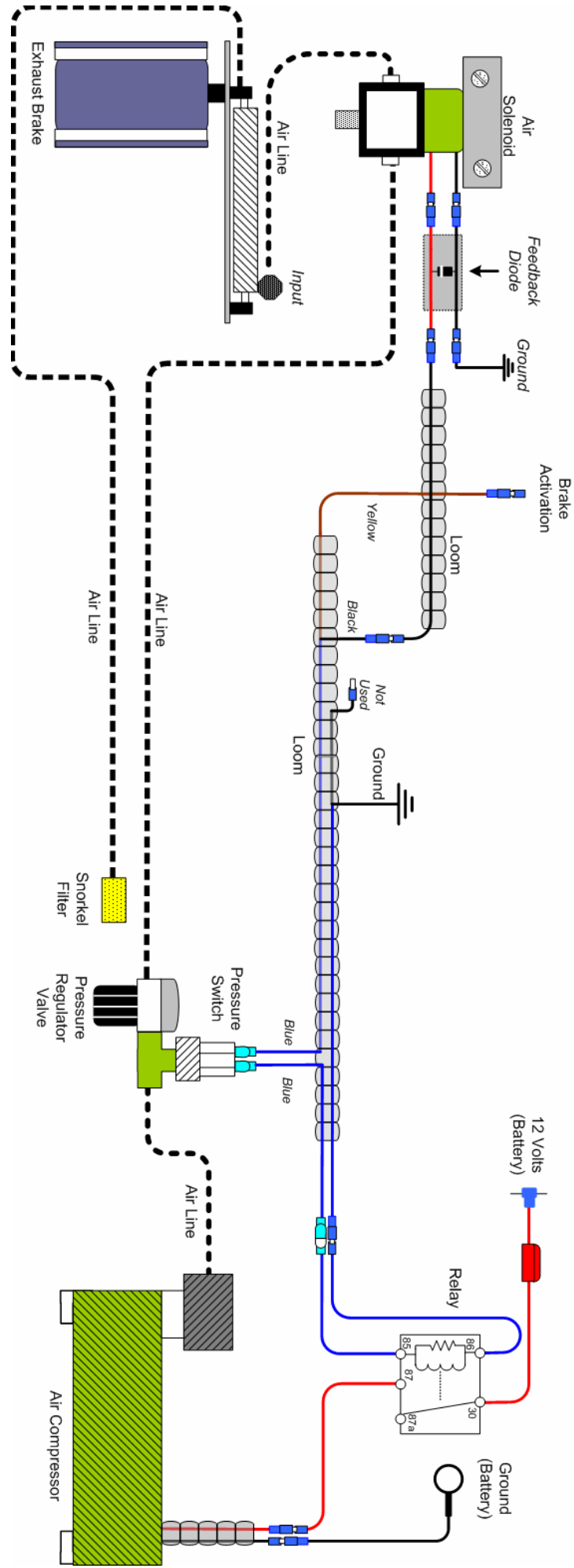

BD ENGINE BRAKE, INC.

Plant Address: A10-33733 King Rd, Abbotsford, BC, Canada V2S 7M9

US Shipping Address: 88-446 Harrison St, Sumas, WA 98295 US Mailing Address: PO Box 231, Sumas, WA 98295

Phone: 604-853-6096 Fax: 604-853-8749 Internet: www.bd-power.com

Cab Wiring

CAUTION: Before installing any wiring modifications or equipment, ensure to disconnect the battery Ground (Negative) terminals on all the vehicle batteries as damage to the vehicle's ECU and/or installed components may result.

For 2005 trucks that are equipped with the up fitter switches, you may wire these 12V inputs into the toggle switch input of the brake controller.

Consult the diagram on the next page for proper connections.

BD ENGINE BRAKE, INC.

Plant Address: A10-33733 King Rd, Abbotsford, BC, Canada V2S 7M9

US Shipping Address: 88-446 Harrison St, Sumas, WA 98295 US Mailing Address: PO Box 231, Sumas, WA 98295

Phone: 604-853-6096 Fax: 604-853-8749 Internet: www.bd-power.com

Remove the lower section of dash, under the steering column, and mount the 6.0L Brake Control module to the cross member. Connect the black wire from the 6.0L Brake Control module to a good clean ground using the round eyelet. You will also use this ground point for the on/off switch (black wire).

Locate one of the ignition switched Red /Black tracer wires under the steering column (one is 10/12ga and the other is 14/16ga) and connect an appropriate Posi-Tap connector to it (green for 10/12ga and black for the 14/16ga wire). Also note that fuse #29 in the central junction box underneath the dash will also work. Connect the red wire from the 12V (Switched power) input of the brake controller to this Posi-Tap. You should also use this connection to power the on/off switch (red wire).

When wiring the on/off switch be sure to leave yourself enough wire length when mounting the switch in the dash. You will need to drill a 1/2" hole in the dash to accommodate the toggle switch. Connect the ground (black) and power (red) wires to the switch using the supplied female blade connectors. The ground wire must be connected to the terminal labeled "AMBER". The provided tan wire should go to the TOGGLE SWITCH terminal on the brake controller and be connected to the output of the switch.

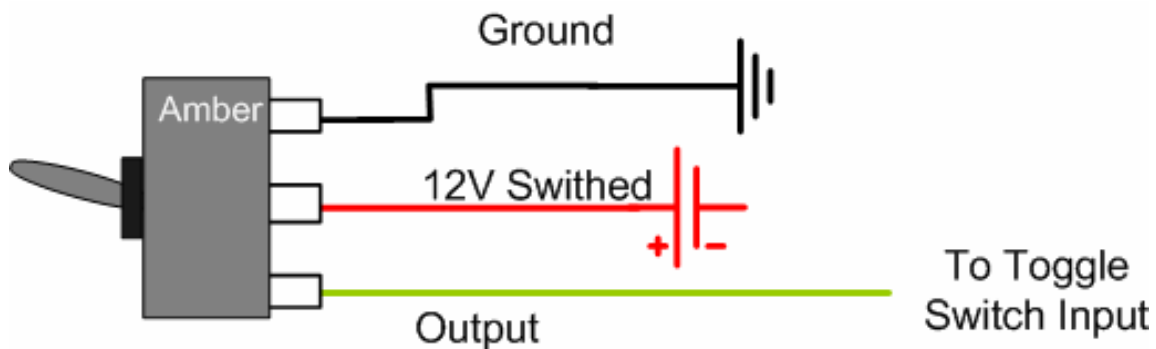

Locate the Throttle Position Sensor at the throttle pedal and, using a Posi-Tap connector, attach the **Yellow** wire from the brake controller module to the correct APPS/TPS wire. If this wire does not exist, you will need to locate a wire that varies its voltage according to how much the throttle is depressed (0.5V to 4.5V). This wire should be connected to the APPS/TPS terminal of the brake controller.

Vehicle Year	APPS/TPS Wire Color
2003-2004	Yellow w/white
2005-2006	White w/Red

Optional Shifter Switch

Mount the shifter switch onto the shift lever using the clamp supplied (either 5/8" or 3/4"). Run the electrical cable down the shifter shaft, securing the cable with zip-ties or electrical tape, and run it under the carpet to the firewall and under the dash to the relays, leaving enough slack for proper shifting of the transmission lever and to prevent rubbing of wire.

At the end of the cable, cut off any excess and strip away about 1 to 2 inches of the black rubber covering exposing the Black and White (or Green) wires then strip the insulation from the ends of the two wires.



Connect the White (or Green) wire to the "Switch" terminal on the 6.0L Brake Module.

Attach a male blade connector to the Black wire. Remove the fused Red wire from the toggle switch (the toggle switch and remaining Red and Black wire attached to the switch will no longer be needed) and attach to the Black wire from the optional switch to the female connector of the fused Red wire.

Locate one of the ignition switched Red /Black tracer wires under the steering column (one is 10/12ga and the other is 14/16ga) and connect an appropriate Posi-Tap connector to it (green for 10/12ga and black for the 14/16ga wire) then connect the fused Red wire to this Posi-Tap.

BD ENGINE BRAKE, INC.

Plant Address: A10-33733 King Rd, Abbotsford, BC, Canada V2S 7M9

US Shipping Address: 88-446 Harrison St, Sumas, WA 98295 US Mailing Address: PO Box 231, Sumas, WA 98295

Phone: 604-853-6096 Fax: 604-853-8749 Internet: www.bd-power.com

PCM Wiring

You will now need to connect three wires to the vehicle's PCM. Push the white, grey and purple wires through the firewall from the underneath the hood. Run the pink wire through the firewall as well (this will be used later on). Connect the grey wire to the VSS terminal, the white wire into the EBP INPUT terminal and the purple wire to the EBP OUTPUT terminal of the brake controller.

Note: To access the PCM you will need to remove the battery cover on the driver side of the vehicle.

Remove the locking plugs from the ECM for easier access.

Use the supplied Posi-tap to connect the grey wire to the Vehicle Speed Sensor (VSS) wire. This wire is grey w/black tracer and is located on **connector A** (closest

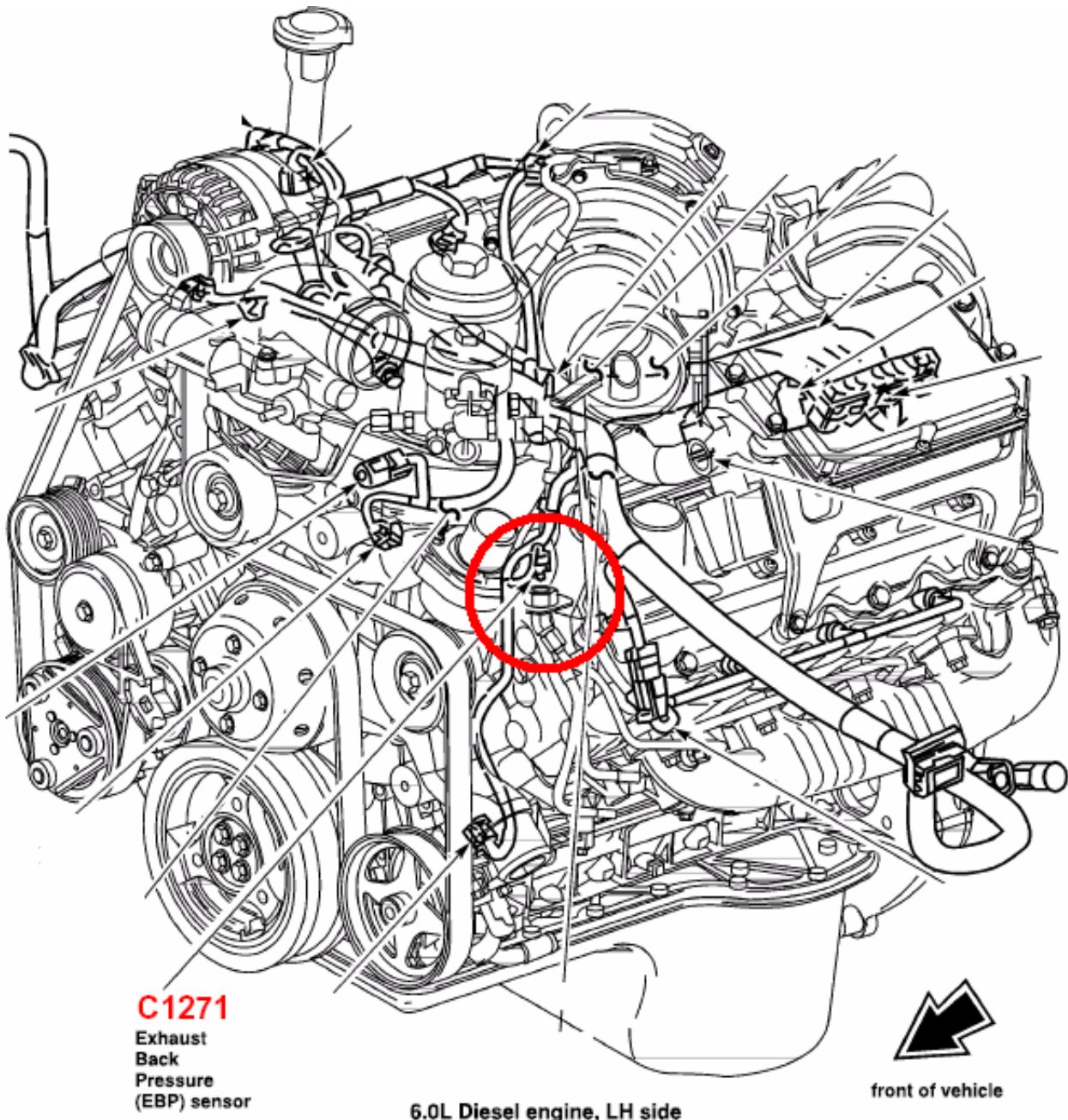

BD ENGINE BRAKE, INC.

Plant Address: A10-33733 King Rd, Abbotsford, BC, Canada V2S 7M9

US Shipping Address: 88-446 Harrison St, Sumas, WA 98295 US Mailing Address: PO Box 231, Sumas, WA 98295

Phone: 604-853-6096 Fax: 604-853-8749 Internet: www.bd-power.com

to the driver), **pin 35**. This wire should be connected to the VSS terminal on the brake controller.

Locate the exhaust back pressure sensor (**EBP**) at the front of the engine on the driver side. Disconnect the factory plugs from the EBP sensor and use the provided connectors to connect to the EBP sensor. Reconnect the factory plug into the provided female plug. When installing the plugs, be sure that no pins get pressed out the backside when inserting the plugs together.

The supplied **violet** wire should be connected to the **EBP OUTPUT** terminal, while the supplied **white** wire should be connected to the **EBP INPUT** terminal of the exhaust brake controller.

Please reference the wiring diagram to remove any discrepancies that you may have.

You may now reinstall the PCM connectors and the battery cover.

Cruise Control Wiring

NOTE: If the vehicle does not have Cruise Control, remove the Green and Blue wire from the install and discard.

You will now need to locate the 8 pin connector located just underneath the steering column on the passenger's side. In this connector will be the speed control switch input **Light Blue/ Black** wire. Attach the supplied red scotch-lok connector to this wire. Attach the male spade connector to the supplied green wire and connect it to the fore mentioned scotch-lok. This green wire should then be wired into the "CRUISE IN" input of the brake controller. The supplied blue wire should then be wired to ground and then into the "CRUISE OUT".

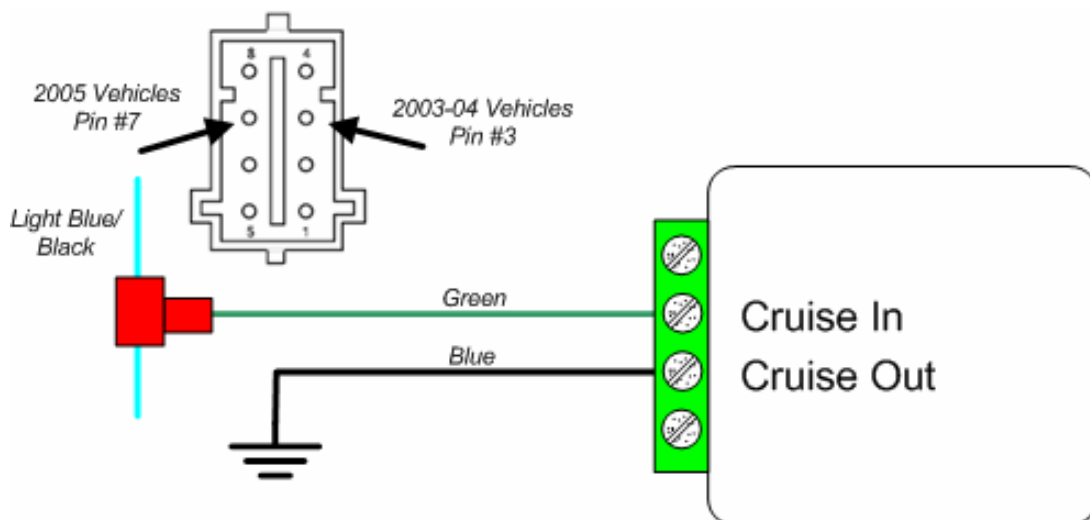

Please note for this change you the Exhaust Brake Controller will have to be version 1.30.

BD ENGINE BRAKE, INC.

Plant Address: A10-33733 King Rd, Abbotsford, BC, Canada V2S 7M9

US Shipping Address: 88-446 Harrison St, Sumas, WA 98295 US Mailing Address: PO Box 231, Sumas, WA 98295

Phone: 604-853-6096 Fax: 604-853-8749 Internet: www.bd-power.com

Control Wiring

Connect the **pink** wire that was brought through the firewall to the **BRAKE OUTPUT** of the brake controller. This wire should be routed along the top of the firewall, under the hood. You must keep this wire away from the turbocharger, as exposed heat will melt this wire. You will need to connect a female bullet connector to the end of the pink wire, which then should be connected to yellow wire located in the pressure switch loom.

Battery Reinstall

Re-install the passenger side battery. Reconnect the positive terminals on both batteries then reconnect the negative terminals.

Brake Controller Calibration

Ensure the connections of the corresponding wires to the Brake Controller Module are correct as shown in the wiring diagram.

To achieve the correct setting for the activation of the exhaust brake in relation to the throttle pedal the Brake Controller Module must be calibrated for your vehicle.

The Brake Controller has an LED inside of the case that should be visible through the case indicating brake activation.

With the throttle at idle, start the engine and turn on the brake switch. Using a small flat bladed screwdriver, turn the small adjusting screw (potentiometer) on the right side of the Brake Control Module counterclockwise or clockwise until the brake engages and the LED JUST turns on.

Hold the small test button on the side of the Brake Controller during this process. This button must be pressed to calibrate the engagement/disengagement point of the exhaust brake, as normally the exhaust brake disengages at 15mph.

CAUTION: THE ADJUSTING SCREW IS A MICRO-SWITCH WHICH IS VERY DELICATE, SO TURN USING SMALL ADJUSTMENTS.

Test by revving up the engine to approximately 1000 RPM and releasing the throttle. As the accelerator pedal is applied, the test light should turn off just before the engine starts to rev, indicating proper calibration of the Brake Controller Module with the TPS. Remember to keep the test button depressed.

BD ENGINE BRAKE, INC.

Plant Address: A10-33733 King Rd, Abbotsford, BC, Canada V2S 7M9

US Shipping Address: 88-446 Harrison St, Sumas, WA 98295 US Mailing Address: PO Box 231, Sumas, WA 98295

Phone: 604-853-6096 Fax: 604-853-8749 Internet: www.bd-power.com

The exhaust brake and LED should activate again when the throttle pedal returned to idle. If not, readjust the Brake Control Module so that it does. Reinstall lower dash cover.

Exhaust Brake Testing

Start the vehicle and check for idle pressure.

The idle pressure should be preset at 10–15 lbs from the factory, so it should not need to be adjusted. If an adjustment is thought to be necessary, please go to the exhaust brake adjustment section.

NOTE: The butterfly valve has been preset at the factory and should not be adjusted.

Start the vehicle and take it for a test drive. The brake will only engage above 15 mph - it will not operate below this speed. Take the vehicle above this set speed, turn on the brake activation switch and let off of the throttle. The brake should apply and you should feel the vehicle slow down. Once 15 mph is reached, the brake will disengage automatically. Accelerate past the threshold speed once more, and let off the throttle once again. Re-apply the throttle and make sure the brake **quickly** disengages.

The brake must quickly disengage, if it does not, a PCM error code may be generated. Some common reasons for a slow reacting brake would be from the brake controller not being adjusted correctly, or the air solenoid valve being too far away from the brake.

Next you will need to test the brake for maximum retarding pressure. You can either do this under load from a large hill or perhaps from letting off the throttle at a high RPM.

The regulated pressure is adjusted with the regulator on the control assembly and has been preset to allow a MAXIMUM of 45psi of exhaust back pressure. Note that you should try to attain this maximum pressure.

CAUTION: Do NOT exceed 45 psi of back pressure.

If for some reason you do not have a back pressure gauge, you can measure the voltage at the “EBP IN” pin of the 6.0L Brake Controller. Under peak exhaust brake use (High Load & High RPM) you should see just below **4.0 Volts**.

While driving, turn on the cruise control, and then activate the brake. The activation of the brake should disconnect the cruise control. Turn the brake off and activate

BD ENGINE BRAKE, INC.

Plant Address: A10-33733 King Rd, Abbotsford, BC, Canada V2S 7M9

US Shipping Address: 88-446 Harrison St, Sumas, WA 98295 US Mailing Address: PO Box 231, Sumas, WA 98295

Phone: 604-853-6096 Fax: 604-853-8749 Internet: www.bd-power.com

cruise control again, this time pressing down on the hydraulic brake pedal to ensure that the cruise control disconnects when the brake pedal is applied.

You may also notice that every time the vehicle is started, the exhaust brake is cycled for a 1/10th of second. This should help everything stay free and clear and reduce the possibility of the valve being contaminated.

NOTE: Over the next two weeks, the backpressure at idle may rise due to the initial carbon build up and the brake valve will need to be adjusted again.

Check for any exhaust leaks and re-check all connections and hoses for security and interference from moving or heated items. After about 100 miles (160 km), re-torque the turbo exhaust clamp and flange bolts.

Maintenance & Troubleshooting

Your exhaust brake has been designed so that every time the vehicle is started the exhaust brake will cycle for 1/10th of a second. This will extend the operating life of the brake substantially.

On a twice-yearly interval, check and adjust the brake pressure to 10-15 lbs while the engine is at idle. The hoses, wires, fittings and clamps should be inspected on a regular basis for any deterioration, damage, or leaks.

By following the diagrams in this manual, trace hoses and wiring, check continuity through electric components, and check for any lines that are disconnected.

This should solve any problems that may arise but if you should need any assistance or need replacement parts, call our **Technical Service** department at 1-800-887-5030, between 8:30am and 4:30pm Pacific Time.

Common Problems

Brake cycles ON/OFF upon disengagement speed – To cure this problem, a new ground should be found for the Brake Controller. Electrical noise on the ground and the VSS line cause this symptom.

Brake does not activate – Check all the wire connections and make sure that when the brake is supposed to be energized that 12V exists on the Brake output of the Brake Controller. Whenever the brake is supposed to be energized, a red LED should be lit inside of the brake controller. You can check this operation by pressing the test button on the side of the controller. Check to make sure that the idle

BD ENGINE BRAKE, INC.

Plant Address: A10-33733 King Rd, Abbotsford, BC, Canada V2S 7M9

US Shipping Address: 88-446 Harrison St, Sumas, WA 98295 US Mailing Address: PO Box 231, Sumas, WA 98295

Phone: 604-853-6096 Fax: 604-853-8749 Internet: www.bd-power.com

verification potentiometer has been adjusted correctly and that the activation switch is in the ON position and is providing 12V to the switch input.

Upon disengagement of brake, Vehicle bogs down – Make sure that the feedback diode wiring assembly is installed at the solenoid valve. Without this, sporadic operations will result.

Exhaust Brake Adjustments

As mentioned in these installation instructions, the backpressure must be measured and adjusted when the vehicle is at idle. There is a 1/8" NPT port on the side of the exhaust brake casting designed for a pressure gauge.

It is required that a standard pressure gauge be used to make the necessary adjustments to the brake valve. Adjust the brake to reach approximately 10-15 lbs while the engine is at idle.

You will need to loosen the stop bolt on the top of the exhaust brake. To do this, first loosen the locknut and then turn the stop bolt in (clockwise) into the exhaust brake frame. Activate the brake. At this time the brake will stroke until it hits the side of the valve casting. Re-adjust the stop bolt until it touches the actuator arm, then turn it another 60° so that the stop bolt pushes the valve just off the side of the casting. Tighten the locknut and check the back pressure gauge for the 10-15 psi idle pressure. If you are still having problems, please contact BD Technical Support.

**DO NOT SET THE VALVE TO STROKE AGAINST THE VALVE CASTING WALLS
AS WARRANTY WILL BE VOIDED.**

Operating Guidelines

Thank you for taking interest in the BD Engine Exhaust Brake. As a driver, you probably already know the need for extra braking power that your vehicle requires on the hills and long grades. With loads being towed behind you, the extra push when slowing down or maintaining speed on downward grades can prove to be a great strain on the vehicle hydraulic braking system, even to point of "burn-up".

These guidelines were designed to offer a better understanding of the benefits of using exhaust brakes and are based on material developed by the US Department of Transportation National Highway Traffic Safety Administration.

The emphasis on today's vehicles is to give the consumer a product that can give them usable power with fuel efficiency. But, in the transition, the vehicles have lost their natural braking power, making it more easy for the vehicle to continue to roll and harder to stop. Of course, this gets more noticeable with the increase of weight,

BD ENGINE BRAKE, INC.

Plant Address: A10-33733 King Rd, Abbotsford, BC, Canada V2S 7M9

US Shipping Address: 88-446 Harrison St, Sumas, WA 98295 US Mailing Address: PO Box 231, Sumas, WA 98295

Phone: 604-853-6096 Fax: 604-853-8749 Internet: www.bd-power.com

on or behind the vehicle. This is where an exhaust brake becomes a useful tool in increasing the driveline drag of the vehicle without the use of the hydraulic brakes.

A tool, with maximum use or even occasional use, that can reduce wear on hydraulic braking parts and at the same time increase safety. The BD Exhaust Brake can be used to help maintain a controlled vehicle speed on a downward grade, as well as slowing the vehicle down for such times as turns or exit ramps, without you using your hydraulic brakes.

However, the exhaust brake cannot be used as a parking brake or a service brake to bring your vehicle to a complete stop.

By using a BD Exhaust Brake, the life and effectiveness of your hydraulic brakes will increase. This is because of the decreased use of the hydraulic brakes in situations like hills, the wear factor is reduced and there is less opportunity for your hydraulic brakes to heat up which would reduce the efficiency.

When you ride your hydraulic brakes, make hard stops or have poorly adjusted brakes, this creates high temperatures and as your brakes get hotter, the more chance there is for fading or failure. With terrain that is a series of up and down grades, the BD Exhaust Brake will aid in reducing exhaust valve warpage. Because of the power needed to pull your vehicle and load up a hill, this generates a lot of heat.

When you have reached the crest of the hill and are now coasting down the other side, the heated valves are too quickly cooled. With the exhaust brake engaged, the heat loss to the valves will be reduced, which can prevent valve warpage. When the toggle switch is turned to the "On" position, the valve is activated every time the driver takes his foot off of the throttle pedal. When the driver puts pressure back on the throttle pedal, the relay is activated and the valve opens again.

Exhaust brakes are designed to operate with the throttle at idle, not to be used in conjunction with cruise controls, and not designed to aid in gear shifting. Such cases could cause damage to engine and/or the exhaust brake. Vehicles may require downshifting to obtain the necessary retarding force.

Automatic transmissions with lock-up clutches in the converters can achieve the best retarding force with the use of a clutch control device (i.e. AutoLoc).

Incorporated with the BD Exhaust Brake, there is a pressure regulating system that will control the created backpressure. If the backpressure reaches the set limit, the exhaust valve will open slightly to relieve the excess pressure.

The brake pressure at idle is required to be checked and adjusted at time of installed, two weeks after installed, and on a regular twice a year interval.

BD ENGINE BRAKE, INC.

Plant Address: A10-33733 King Rd, Abbotsford, BC, Canada V2S 7M9

US Shipping Address: 88-446 Harrison St, Sumas, WA 98295 US Mailing Address: PO Box 231, Sumas, WA 98295

Phone: 604-853-6096 Fax: 604-853-8749 Internet: www.bd-power.com

Using a standard pressure gauge and the pressure port on the exhaust valve, the brake pressure at idle must be set between 10 and 15 psi. The best scenario for exhaust braking is when going down hill, select a gear that lets you maintain a constant speed with little or no use of the hydraulic brakes, or, the same gear that would be used to go up the same grade of hill. This also depends on the weight, load or road conditions that the vehicle will come upon.

Therefore, in summary, by using the BD Exhaust Brake, you reduce the need for use of your hydraulic brakes in situations where you need to slow down or maintain (i.e. hills, off ramps, corners, approaching speed changes or traffic lights). By reducing the use of your hydraulic brakes in these situations, this reduces the heat build up, as well as wear and damage to linings and drums. And, when you reduce these factors, you save your hydraulic brakes for when you really need them (i.e. for stopping or emergencies).

The BD Exhaust Brake is not a substitute for your hydraulic brakes and, cannot correct or compensate for poorly maintained or misadjusted brakes. But, when you need to slow down or maintain a constant speed, the BD Exhaust Brake will be a valuable and effective tool. Exhaust Brakes are more efficient at preventing than correcting an over-speed condition.

You may also notice that every time the vehicle is started the exhaust brake is cycled for a 1/10th of second. This should help everything stay free and clear and reduce the possibility of the valve being contaminated.

Thank you and happy motoring,

BD Engine Brake, Inc.

BD ENGINE BRAKE, INC.

Plant Address: A10-33733 King Rd, Abbotsford, BC, Canada V2S 7M9

US Shipping Address: 88-446 Harrison St, Sumas, WA 98295 US Mailing Address: PO Box 231, Sumas, WA 98295

Phone: 604-853-6096 Fax: 604-853-8749 Internet: www.bd-power.com

BD ENGINE BRAKE, Inc. *LIMITED WARRANTY STATEMENT*

THE INSTALLATION OF THIS PRODUCT INDICATES THAT THE BUYER HAS READ AND UNDERSTANDS THIS AGREEMENT AND ACCEPTS ITS TERMS AND CONDITIONS.

DISCLAIMER OF LIABILITY

BD Engine Brake Inc., its successors, distributors, jobbers, and dealers (hereafter "**BD**") shall in no way be responsible for the product's proper use and service. THE BUYER HEREBY WAIVES ALL LIABILITY CLAIMS.

BD disclaims any warranty and expressly disclaims any liability for personal injury or damages. **BD** also disclaims any liability for incidental or consequential damages including, but not limited to, repair labor, rental vehicles, hotel costs, or any other inconvenience costs by reason of use or sale of any such equipment. The **BUYER** acknowledges and agrees that the disclaimer of any liability for personal injury is a material term for this agreement and the **BUYER** agrees to indemnify **BD** and to hold **BD** harmless from any claim related to the item of any equipment purchased.

This warranty shall not apply to any unit that has been improperly stored or installed, or to misapplication, improper operation conditions, accidents, neglect, or which has been improperly repaired or altered or otherwise mistreated by the **BUYER** or his agent. **BD** also assumes no liability regarding the improper installation or misapplication of its products. It is the installer's responsibility to check for proper installation and if in doubt, contact the manufacturer.

LIMITATION OF WARRANTY

BD Engine Brake Inc. (hereafter "**BD**") warrants to the **BUYER** that any parts purchased shall be free from defects in material workmanship. A defect is defined as a condition within the product that would render the product inoperable. **BD** gives Limited Warranty as to description, quality, merchantability, fitness for any product's purpose, productiveness, or any other matter of **BD's** product sold herewith. **BD** shall be in no way responsible for the product's open use and service and the **BUYER** hereby waives all rights other than those expressly written herein. This Warranty shall not be extended or varied except by a written instrument signed by **BD** and the **BUYER**.

The warranty is limited to two (2) years from the date of sale. Labor costs incurred by the removal and replacement of the BD product, while performing warranty work, will be covered for 1 (one) year, payable at BD rates, at authorized centers and with prior approval. Until BD has approved the claim, the consumer may be responsible for these costs.

A Return Authorization (WA) number, obtained in advance from **BD**, must accompany all products returned for warranty consideration. All products must be returned, shipping prepaid, to **BD** and must be accompanied by a dated proof of purchase receipt. All Warranty claims are subject to approval by **BD** and repaired or replaced product will be returned to the customer freight collect. Accepted warranty units, which have been replaced, become the sole property of **BD**.

This warranty is in lieu of all other warranties or guaranties, either expressed or implied, and shall not extend to any consumer or to any person other than the original purchaser residing within the boundaries of the continental U.S. or Canada.

IN THE EVENT THAT THE BUYER DOES NOT AGREE WITH THIS AGREEMENT, THE BUYER MAY PROMPTLY RETURN THIS PRODUCT, IN A NEW AND UNUSED CONDITION, WITH A DATED PROOF OF PURCHASE, TO THE PLACE OF PURCHASE WITHIN THIRTY (30) DAYS FROM DATE OF PURCHASE FOR A FULL REFUND.

BD ENGINE BRAKE, INC.

Plant Address: A10-33733 King Rd, Abbotsford, BC, Canada V2S 7M9

US Shipping Address: 88-446 Harrison St, Sumas, WA 98295 US Mailing Address: PO Box 231, Sumas, WA 98295

Phone: 604-853-6096 Fax: 604-853-8749 Internet: www.bd-power.com