



**DOWNLOAD COLOUR
INSTALL MANUALS AT
www.bddiesel.com**



BD 68RFE Transmission

2007-2022 RAM Pickup 6.7L Cummins Engine

	Year	Drive	Trans. Only	Trans. + Converter
TORQUEMASTER <i>TRANSMISSION (700HP)</i>	07-18	2WD		1064262BM
	07-18	4WD	1064264B	1064264BM
	19-22	2WD	1064292B	1064292BM
	19-22	4WD	1064294B	1064294BM
TOWMASTER <i>TRANSMISSION (600HP)</i>	07-18	2WD	1064262	1064262SS
	07-18	4WD	1064264	1064264SS
	19-22	2WD	1064292	1064292SS
	19-22	4WD	1064294	1064294SS
ROADMASTER <i>TRANSMISSION (500HP)</i>	07-18	2WD	1064222	1064222SS
	07-18	4WD	1064224	1064224SS
	19-22	2WD	1064302	1064302SS
	19-22	4WD	1064304	1064304SS

Please read the instructions and warranty disclaimer before beginning installation.
WARRANTY VOID UNLESS ALL INSTALLATION PROCEDURES ARE FOLLOWED
 All learn procedures should be performed at the operating power setting of the vehicle.
 Special tuning required for 2019-2022 applications for increased pressure.

Contents

Contents	2
DO THIS FIRST	2
Introduction	3
Important	3
Special Tools Required	4
Maintenance.....	4
Aftermarket Tuners and TCMs.....	5
2019+ 68RFE TCC Solenoid PI Curve Re-learn.....	5
Transmission Installation	6
Transmission Removal	6
Transmission Cooler Flush.....	10
Torque Converter Removal	11
Torque Converter Installation	11
Transmission Installation	12
Pressure Test Adapter Installation (2007-2018).....	16
68RFE Pressure Module Installation (2007-2018 Only).....	17
Fluid Fill and Check.....	17
Transmission Quick Learn	17
Road Test and Pressure Checks	21
Drive Learn Procedure.....	22
Final Check and Gauge Removal	22
Returning the Vehicle to the Customer.....	22
Detailed Relearn Information	23
Solenoid Pack Field Replacement.....	27
Troubleshooting	27

DO THIS FIRST

Check off boxes to ensure you do not miss any important steps. Failure to perform some of these steps stated below may void your warranty.

<input type="radio"/> Step 1	Read the transmission warranty statement (With Customer).
<input type="radio"/> Step 2	Complete top part of the transmission warranty form.
<input type="radio"/> Step 3	Ensure you have an OEM or equivalent scan tool. If you do not have this tool, DO NOT INSTALL THIS TRANSMISSION.
<input type="radio"/> Step 4	Record CVI's of stock transmission and record on warranty form BEFORE performing quick learn.
<input type="radio"/> Step 5	Proceed with RE & RE of transmission - see installation instructions below
<input type="radio"/> Step 6	Install BD 68 RFE pressure module or appropriate pressure tuning in the TCM
<input type="radio"/> Step 7	Using pressure adapter kit (1061529) record pressures on warranty sheet.
<input type="radio"/> Step 8	Proceed with relearn procedure while continuing to update warranty sheet

Step 9

Fax warranty sheet to BD diesel and keep a copy for your records.

Introduction

BD Diesel 68RFE Transmissions incorporate many upgrades and updates to improve transmission longevity and performance. See our website for up-to-date sales features.



Check out the following videos on YouTube for installation walk-through and detailed relearn procedure information for the 68RFE transmission.



Transmission Installation Video

[https://w](https://www.youtube.com/watch?v=PdTHNtSRfSo)

www.youtube.com/watch?v=PdTHNtSRfSo



Quick Learn and Drive Learn Video

[https://www.you](https://www.youtube.com/watch?v=MdTH4ZyPXw4)

[tube.com/watch?v=MdTH4ZyPXw4](https://www.youtube.com/watch?v=MdTH4ZyPXw4)

Important

The 68RFE transmission has a unique TCM control strategy and it is imperative the instruction for the “Quick learn” are followed closely. Not following these directions correctly will result in a void warranty and will lead to premature failure. Do not use the vehicle for heavy towing or hauling until 300 miles of stop and go driving has elapsed to allow the computer to relearn the new transmission.



Burnt clutches are not covered by warranty. Failure to correctly adhere to this procedure may result in clutches that look like this.

BD Engine Brake Inc.

1-800-887-5030 | <https://www.bddiesel.com>

Special Tools Required

Scanner

Chrysler Scanners

SCANNER	YEAR
WiTech	2007-Current
Star Mobile	2007-Current
StarScan	2007-2009

Aftermarket Scanners

SCANNER	YEAR
Snap-On Modis	All
Auto Enginuity (with EI04 enhanced Dodge coverage)	All
Other scanners with FULL OE coverage (not code readers)	



300 psi oil filled gauge, with approx. 6ft line with male 1/8" NPT fitting (for applications with line pressure module)



Maintenance

BD recommends the first transmission oil and filter change to occur at the 3 month or 5,000 miles/8,000 km interval. This quick interval will not only give you piece of mind, but will also rid the transmission of any prior debris dislodged from the cooler. After this, OE service intervals are acceptable.

Use only MOPAR ATF+4 or aftermarket equivalent ATF+4 transmission fluid.

These are the only acceptable fluids for use in this transmission.

Aftermarket Tuners and TCMs

2007-2018 Models Using both the controller and tuning will set a P0868 fault code and may cause shift issues. Be sure to disable line pressure changes in your tuner for using the BD pressure controller OR do not use the BD controller if you must use tuning for line pressure.

Other transmission tuning, for example raising the 4-5 and 5-6 shift points will not conflict and may be run with the BD pressure module.

We recommend doing the drive learn process with the tuner set to the power level the truck is normally used at. Do not go full throttle during shifts until the transmission has had time to learn its CVI values.

When tuner power levels change the transmission will have to adapt shift timing, this leads to additional unnecessary wear. We suggest not frequently changing power levels.



2019-2022 Models You must use TCM tuning to increase line pressure on these applications. Do not use an inline pressure module. The factory TCM has programming flaws which will become prevalent at higher line pressure. In higher load conditions, clutches that are not supposed to be applied can pulse on. The only way to correct this at this time is using tuning. Contact your tuner and ensure they know of the issue and have the required workaround **BEFORE** installing their tuning. Suggested WOT line pressure using tuning is 250psi.

2019+ 68RFE TCC Solenoid PI Curve Re-learn

2019-2022 Models Valve bodies are equipped with a Variable Force Solenoid (VFS) for the Torque Converter Clutch (TCC) that has a **unique** close tolerance Pressure/Inductance (PI) curve. It is necessary to update the PI data in the PCM when replacing the TCC solenoid, Valve Body or Transmission assembly.

BD Diesel provides a copy of the unique code from the rectangular QR matrix in the form of an easy-to-scan QR code with this install manual. Ensure to scan and safely store it for future reference.

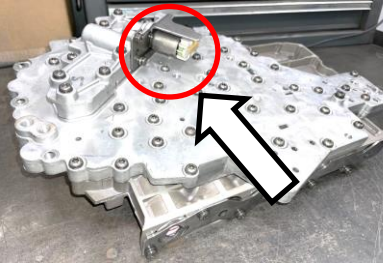
The 46 or 66 characters code must be used to perform a PI Curve re-learn after the transmission installation, but before the initial road test, using the "Program Torque Converter Solenoid PI Curve" routine in scan tool.

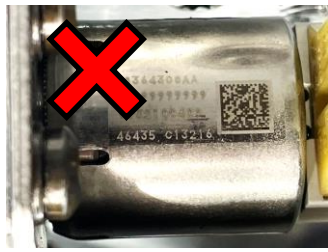
			
<p>BD Printed QR Code (Contains PI Curve info.)</p>	<p>2019+ Auxiliary Valve Body</p>	<p>Rectangular QR matrix (Contains PI Curve info.)</p>	<p>Square QR code (Not PI Curve info.)</p>

Transmission Installation
Transmission Removal

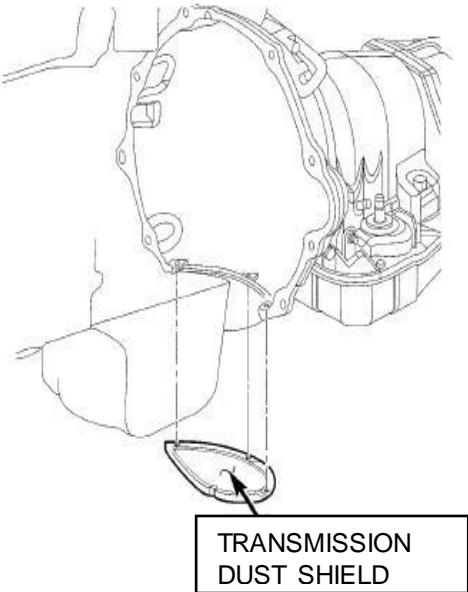
<p>Disconnect the negative battery cable.</p>	
<p>Raise and support the vehicle. Remove any necessary skid plates.</p> <p>Drain transmission.</p> <p>NOTE: Mark drive shaft and axle companion flanges for assembly alignment.</p> <p>Remove the rear drive shaft.</p> <p>Remove the front drive shaft, if necessary.</p> <p>Remove the exhaust support bracket from the converter housing.</p> <p>Remove the bolts securing the right power bending bracket to the engine block and the transmission adapter plate.</p> <p>Remove the right side power bending bracket.</p> <p>Loosen the inspection cover bolts and rotate the inspection cover out of the way.</p> <p>Remove the transmission dust shield.</p>	

Rotate the fly wheel by using the Chrysler barring tool # 7471B or a blade screw driver and remove the torque converter bolts one at a time.

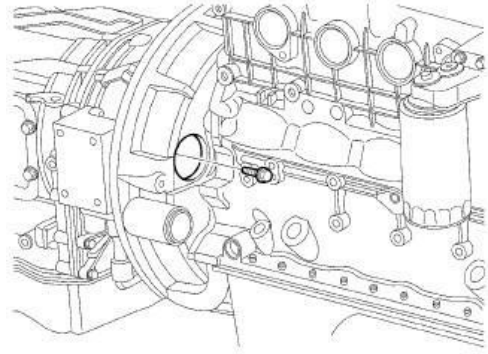

Disengage the output speed sensor connector from the output speed sensor.

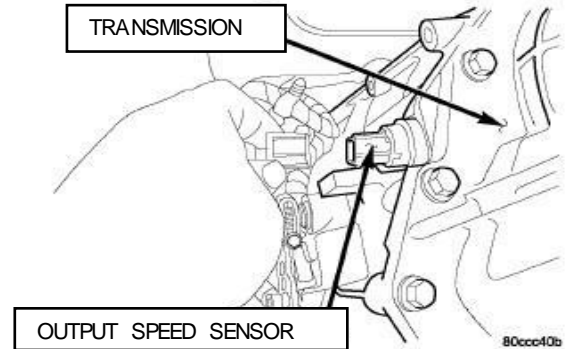

Disengage the input speed sensor connector from the input speed sensor.

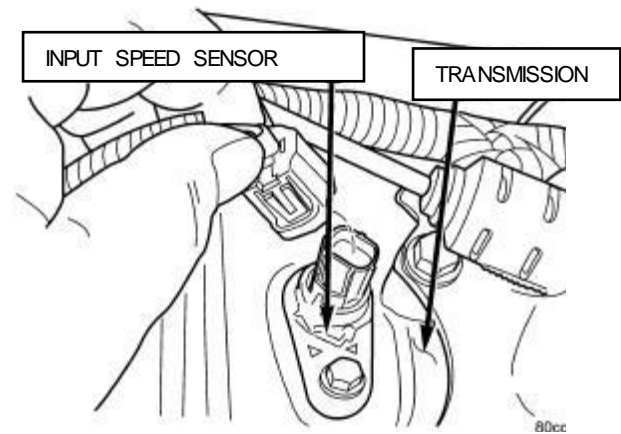

Disengage the transmission solenoid/TRS assembly connector from the transmission solenoid/TRS assembly.

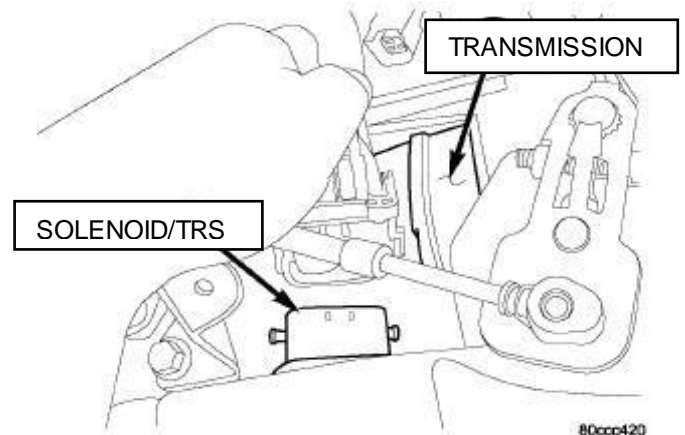

Disengage the line pressure sensor connector from the line pressure sensor. Thoroughly inspect both sides of the connector for corrosion or debris. This has been a known issue and can cause severe damage to the transmission if not corrected.

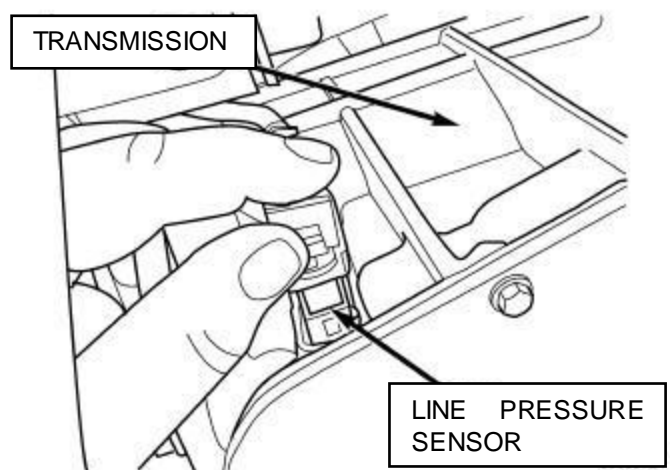

Important Inspection Notes

Corrosion in Connectors

You must check the Transmission Line Pressure connection for corrosion. It is not evident until you pull the yellow cap from the inside of the connector.

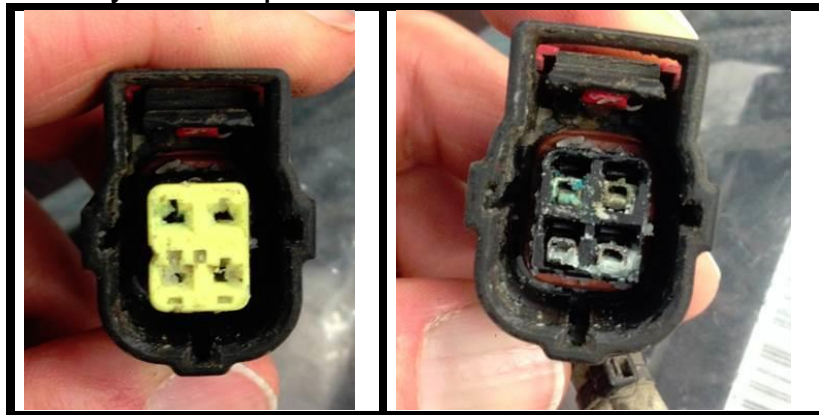

Corroded line pressure sensor connections are known to cause erratic shift quality concerns due to wildly varying transmission line pressure and in some cases cause broken transmission shafts. If corrosion is present, replace the entire connector assembly.

Disconnect electrical connector from the differential pressure sensor.

Remove bolt securing differential pressure sensor to the transmission case and position differential pressure sensor aside.

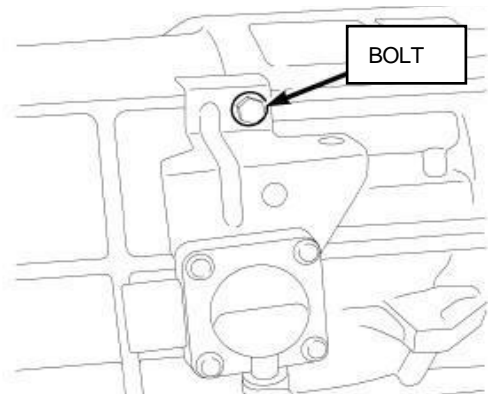

Disconnect gearshift cable from transmission manual valve lever.

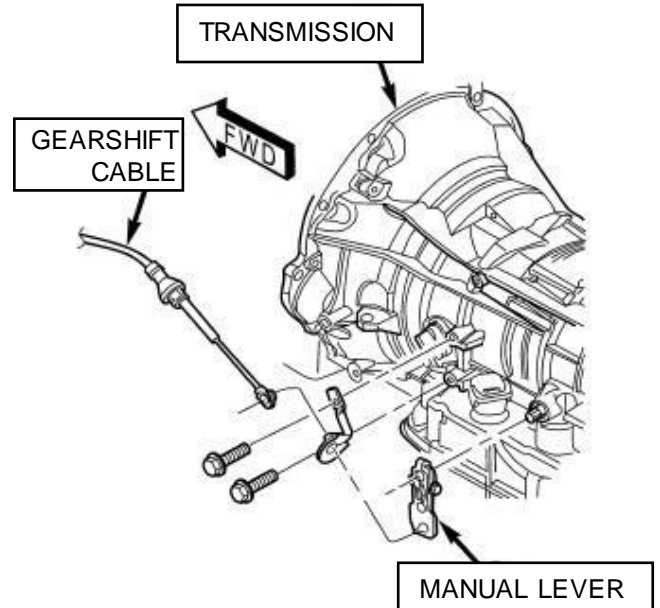

NOTE: For 2013 and newer vehicles, in preparation of installing the new BD 68RFE transmission, the cooler lines may need to be slightly re-shaped to clear the BD deep sump oil pan.



Remove the wiring harness and position aside.
Remove the bolt securing the fill tube at the transmission.
Disconnect the cooler lines from the transmission using cooler line disconnect tool Chrysler # 9546.

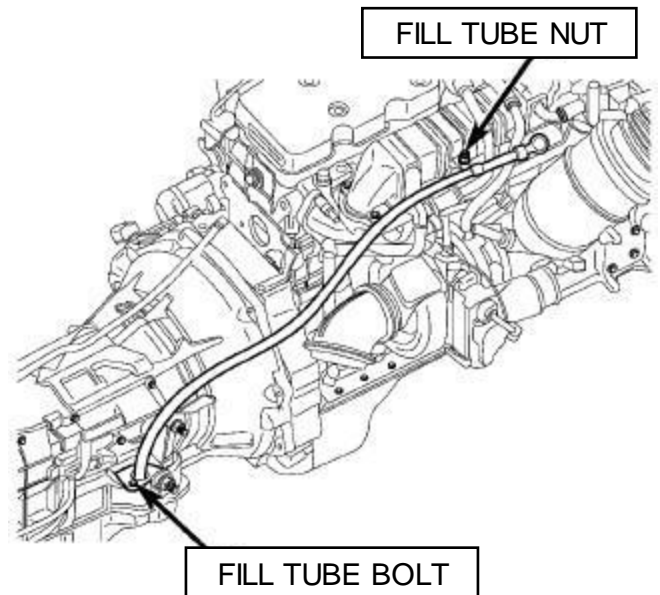

Support rear of engine with safety stand or jack. Raise transmission slightly with service jack to relieve load on crossmember and supports.

Remove the wiring harness from the crossmember and position aside.

Remove bolts securing rear support and cushion to transmission and remove the crossmember from the vehicle.

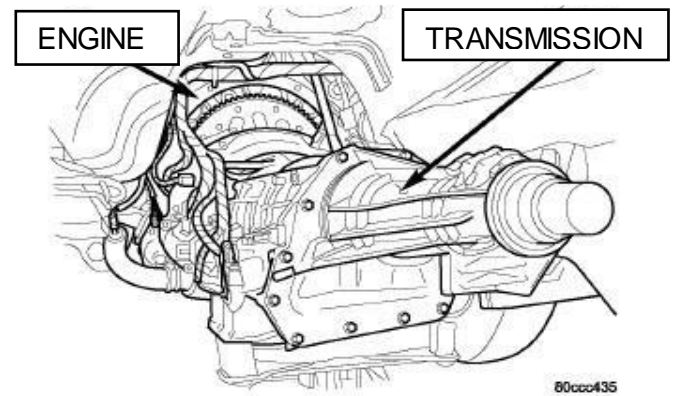

If equipped, Disconnect vent lines and connectors to the transfer case assembly. Remove mounting nuts for the transfer case and remove the t/case from the vehicle.

Disconnect the transmission vent hose from the transmission. Remove all remaining converter housing bolts.

Carefully work transmission and torque converter assembly rearward off engine block dowels while removing the fill tube from the fill tube bore.

Hold torque converter in place during transmission removal. Lower transmission and remove assembly from under the vehicle.

Transmission Cooler Flush

Before installing your BD transmission you must flush the transmission coolers using a backflow heated transmission flushing machine. By not doing this you may void your warranty.

If the transmission you are removing failed or has an excessive amount of debris in the pan, you should replace the transmission cooler and check valve assembly.

Torque Converter Removal

To remove the torque converter from the old transmission, carefully slide torque converter out of the transmission and drain as much fluid as possible.

All components and cores must be drained of fluid before sending back to BD for core credit.

To ship core back, reinstall torque converter using the special retainer plate that came on the new transmission. This will prevent damage during return shipping.

Torque Converter Installation

Upon installation ensure the brass drain plug is installed in the torque converter and preload the torque converter with 5 quarts of MOPAR ATF+4 fluid (Or aftermarket ATF+4). Do not use any other transmission fluid type!

Check torque converter hub and hub drive flats for sharp edges burrs, scratches, or nicks. Polish the hub and flats with 800/1000 grit paper and crocus cloth if necessary. Verify that the converter hub o-ring is properly installed and is free of any debris. The hub must be smooth to avoid damaging pump seal at installation.

Lubricate oil pump seal lip with transmission fluid.

Prefill torque converter with 5 quarts of Mopar ATF+4 or aftermarket ATF+4 before installing.

Align converter and oil pump.

Carefully insert converter in oil pump. Then rotate converter back and forth until fully seated in pump gears.

Check converter seating with steel scale and straightedge. Surface of converter lugs should be in front of the bell housing face about 25 mm (1 in.).

Temporarily secure converter with C-clamp.

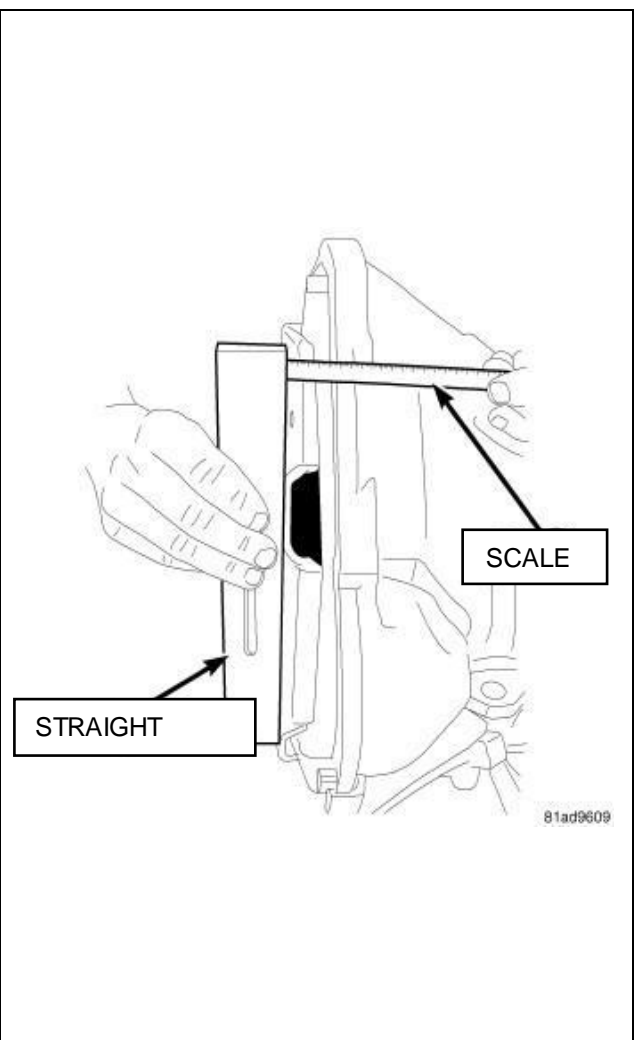

Transmission Installation

Note: *The following items and procedures are critical in the safe operation of your transmission. Failure to follow these recommendations will result in a VOIDED WARRANTY.*

2019-2022 Models: *Before installing the transmission, ensure to safely store the 46 or 66 character code containing the PI Curve information provided with the BD Transmission.*



SAMPLE CODE – NOT FOR USE

Transfer any components necessary, such as the manual shift lever and shift cable bracket, from the original transmission onto the BD performance transmission.

Position transmission on jack and secure it with chains.

Check condition of converter driveplate. Replace the plate if cracked, distorted or damaged. A BD flexplate would make a great upgrade.

Also be sure transmission dowel pins are seated in engine block and protrude far enough to hold transmission in alignment.

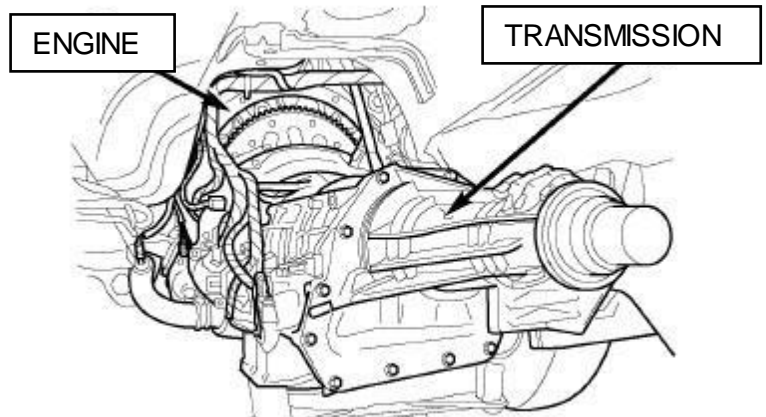

Apply a light coating of Mopar® High Temp Grease to the torque converter hub pocket in the rear pocket of the engine's crankshaft.

Raise transmission and align the torque converter with the drive plate and transmission converter housing with the engine block.

Move transmission forward. Then raise, lower or tilt transmission to align the converter housing with engine block dowels while positioning filler tube into the filler tube bore.

Carefully work transmission forward and over engine block dowels until converter hub is seated in crankshaft. Verify that no wires, or the transmission vent hose, have become trapped between the engine block and the transmission.

Install two bolts to attach the transmission to the engine, and check to ensure the torque converter is still able to rotate.

Install remaining torque converter housing to engine bolts. Tighten to 68 Nm (50 ftlbs).

CAUTION: It is essential that the correct length bolts are used to attach the converter to the flex plate. Bolts that are too long will damage the clutch surface inside the torque converter.

Install torque converter-to-drive plate bolts. Tighten bolts to 88 Nm (65 ftlbs). Thread locker is recommended on the torque converter bolts.

If equipped, Install transfer case. Tighten transfer case nuts to 35 Nm (26 ftlbs). Install rear support to transmission. Tighten bolts to 47 Nm (35 ftlbs).

Install crossmember.

Lower transmission onto crossmember and install bolts attaching transmission mount to crossmember. Tighten clevis bracket to crossmember bolts to 47 Nm (35 ftlbs). Tighten the clevis bracket to rear support bolt to 68 Nm (50 ftlbs).

Remove engine support fixture.

Install the transmission inspection cover. Tighten the bolts to 10 Nm (88 inlbs). Install the right side power bending bracket.

Install the transmission dust shield.

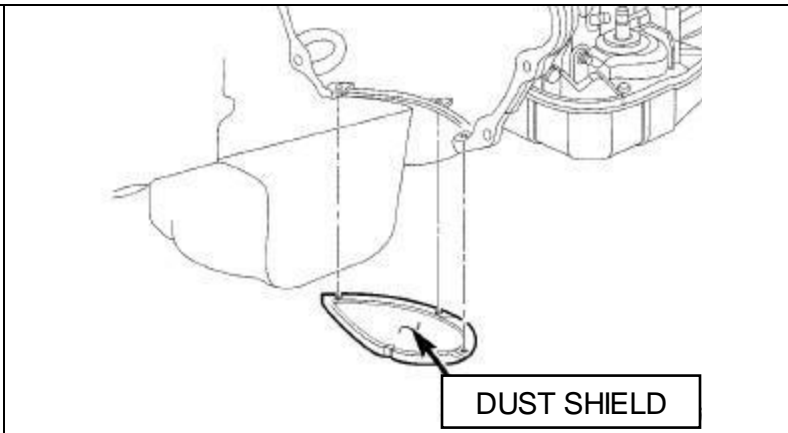

Connect gearshift cable to transmission.

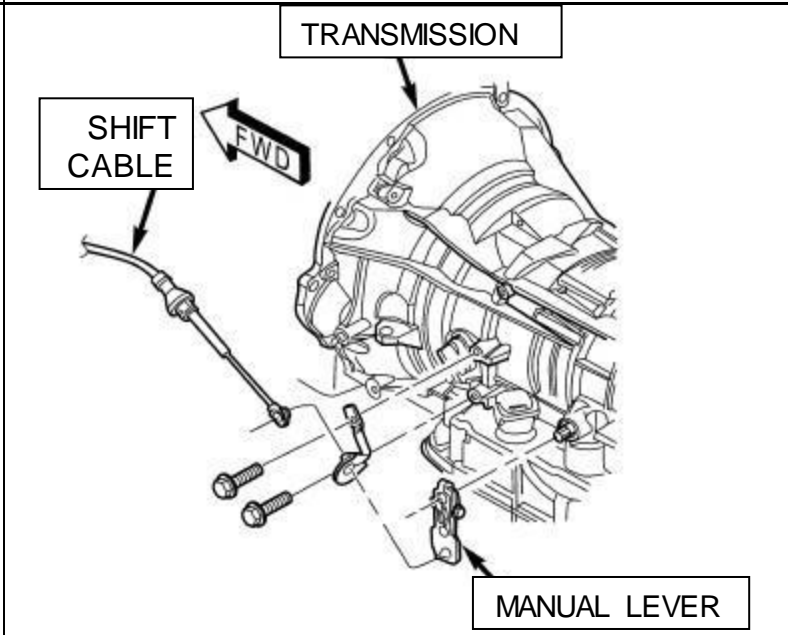

Connect wires to solenoid and pressure switch assembly connector.

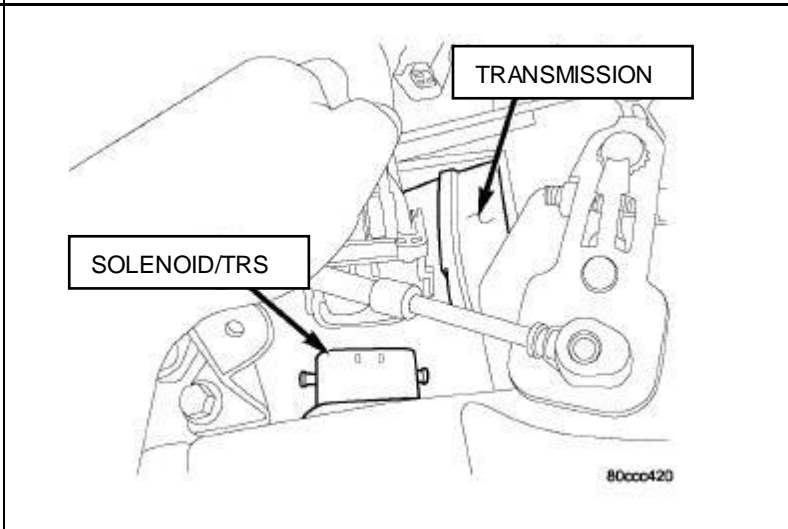

Connect wires to input speed sensor.

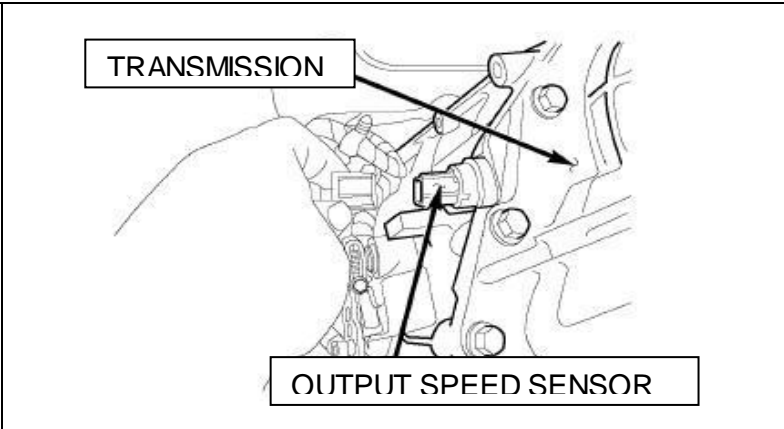

Connect wires to output speed sensor.

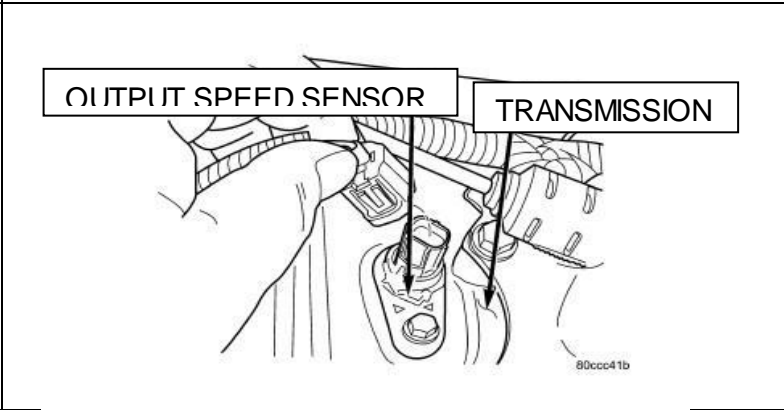

Connect wires to line pressure sensor. Be sure transmission harnesses are properly routed.

NOTE: Use dielectric grease when reconnecting this connector.

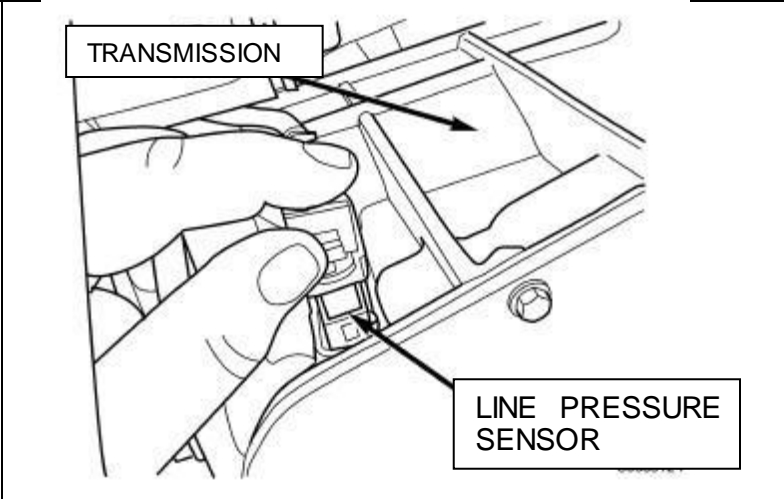

Install the differential pressure sensor bolt (if equipped). Tighten bolt to 10N.m (88 inlbs).

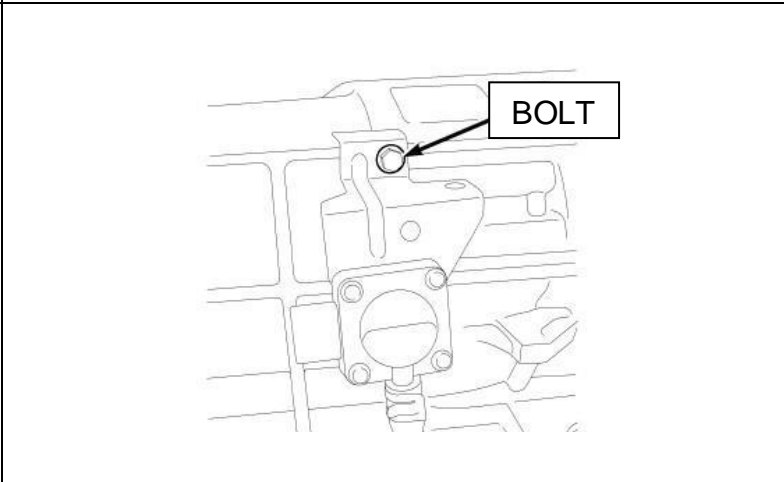

Connect cooler lines to transmission.

Install transmission fill tube bolt.
Tighten bolt to 10 Nm (88 inlbs.)

Install exhaust components, if necessary.

Align and connect drive shaft(s).

Drive Shaft Torque Specs

Front Axle	28 Nm (21 ftlbs)
Front T-Case	88 Nm (65 ftlbs)
Center Bearing Bolts	54 Nm (40 ftlbs)
Rear Bolts	115 Nm (85 ftlbs)

Adjust gearshift cable if necessary.

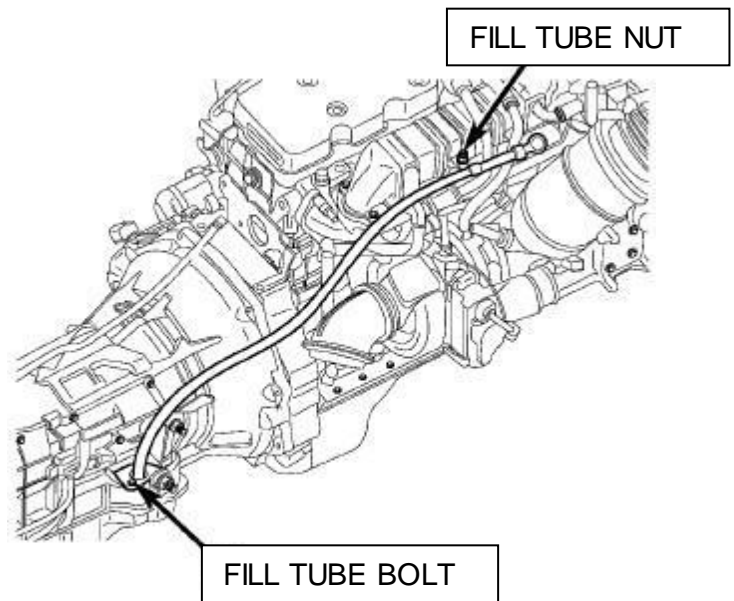

81abb9ac

Pressure Test Adapter Installation (2007-2018)

For 2007-2018 vehicle installations using the BD Line Pressure module you must install the pressure test adapter to measure the actual line pressure. This step is not used for 2019+ models or earlier models which rely on pressure tuning instead.

Disconnect and remove line pressure sensor.

Install pressure adapter with OE sensor back into transmission, attach 300 PSI liquid filled gauge to pressure adapter.

Route gauge from under vehicle into cab leaving sufficient clearance to exhaust system and moving parts. Lower vehicle.

Transmissions that will include BD's Pressure adapter Kit are:

1064262 & 1064262B

1064264 & 1064264B

This Pressure adapter kit should remain with the vehicle for future service.



68RFE Pressure Module Installation (2007-2018 Only)

In order to complete the transmission installation, the Line Pressure Module (1030369) provided with this kit will need to be installed. Please follow the instructions that come with the module kit.

****RoadMaster Applications will have a (1030366)****

Fluid Fill and Check

Fill transmission with MOPAR ATF+4 fluid or applicable aftermarket ATF+4 approved by the manufacturer. (See table below for suggested amounts).

NOTE: Fill capacities listed only as a guide. Correct fluid level should always be determined by marks on dipstick. Capacities listed are total system capacity including torque converter and BD pan.

<u>Application</u>	<u>First Fill Quarts (Liters)</u>	<u>Secondary Fill Quarts (Liters) (Includes TC Preload)</u>	<u>Total Capacity (Liters)</u>
2007.5-2017	12 (11.4)	Approx 10 (9.4)	22 (20.8)

Once transmission fluid is filled, start truck but **do not** drive it yet. Allow the transmission to pump fluid into the converter, coolers etc. Re-check fluid level.

Transmission Quick Learn

CRITICAL STEP!

Connect a Chrysler or equivalent aftermarket scan tool to the vehicle. Clear any existing transmission fault codes from last transmission.

BEFORE you begin the QUICK LEARN process, record the CVI values from the old transmission on your warranty sheet.

2019-2022 Models: Select 'Program Torque Converter PI Curve' in Misc Functions menu and enter the 46 or 66 digit code for the PI Curve which is provided with the BD 2019+ transmission.

Follow the steps in the scan tool and perform 'Quick Learn' when prompted.

1. Select 'Program Torque Converter PI Curve'



2. Click continue.

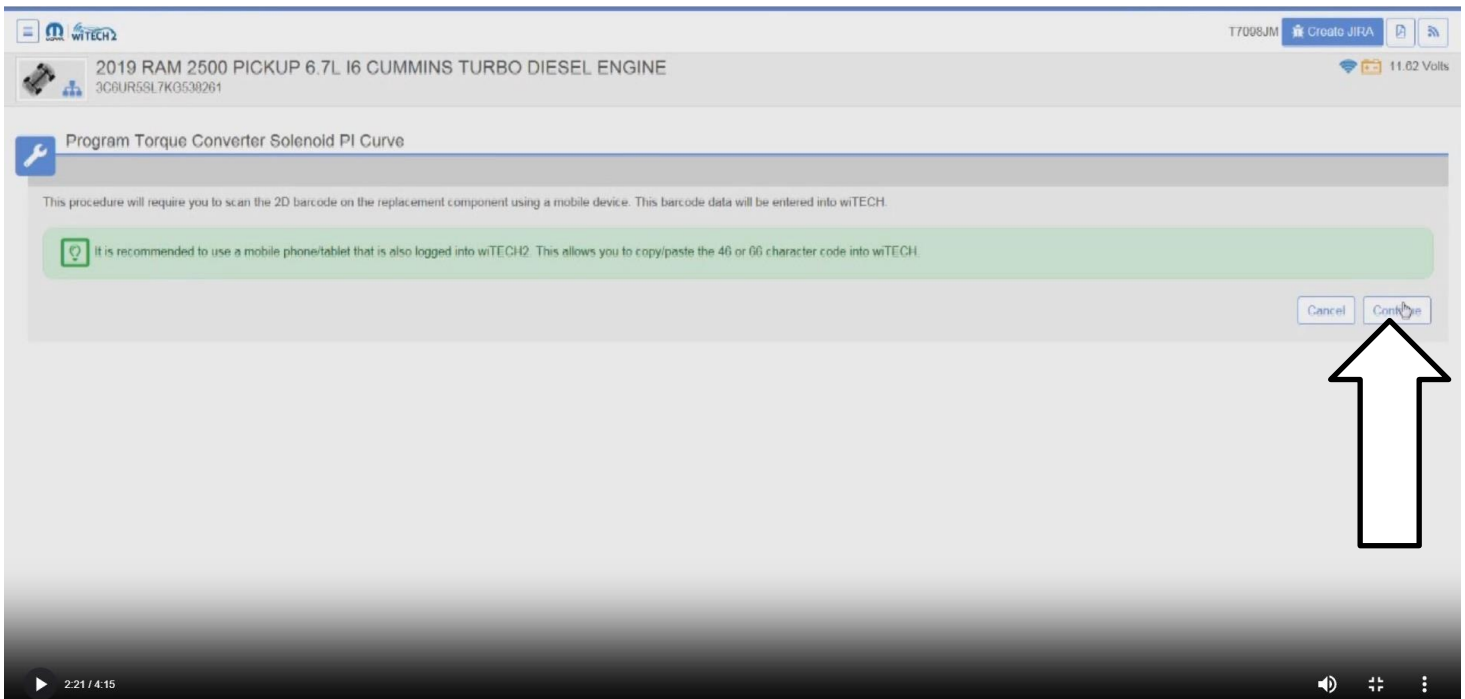

3. Select the Valve Body/Torque Converter Solenoid option and click continue.

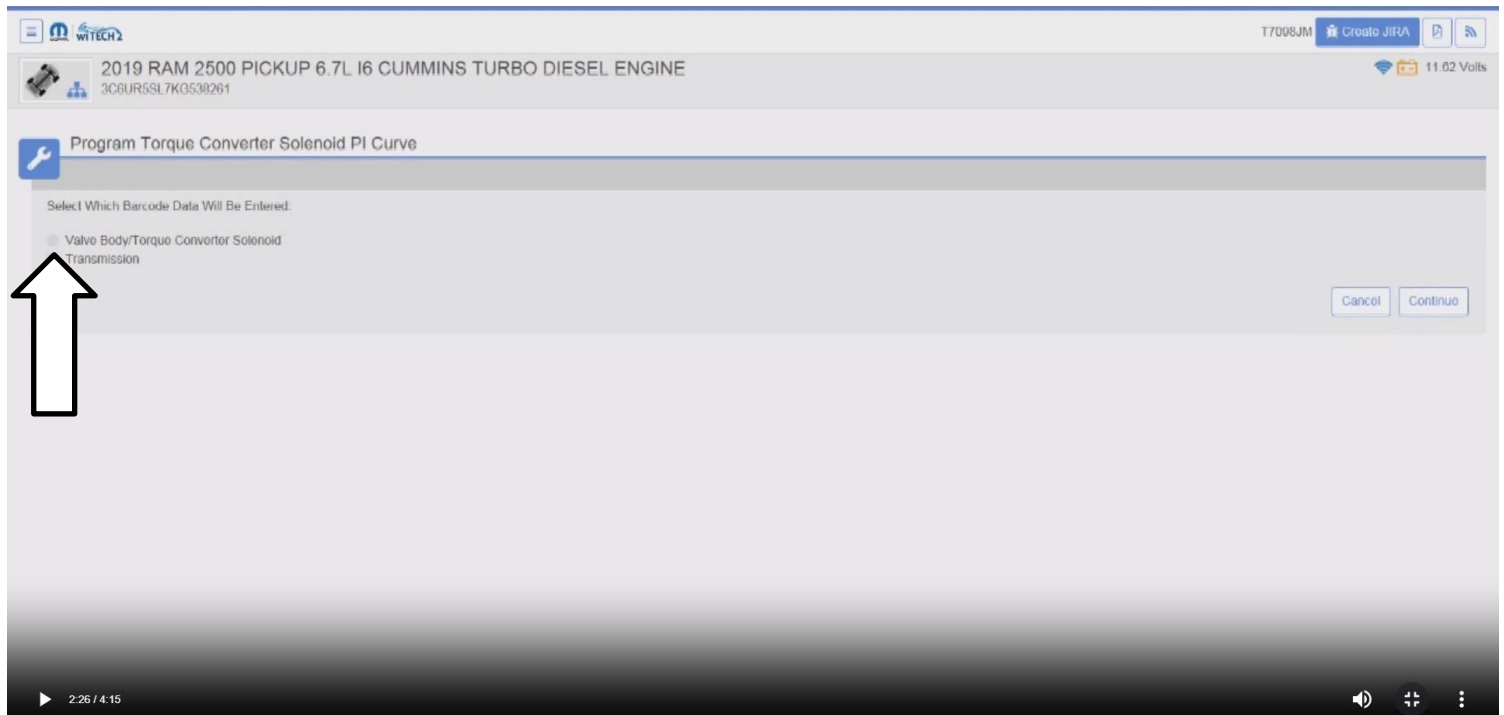

4. Scan and enter the 46/66 characters PI curve information provided on the QR label with the 2019+ transmission.

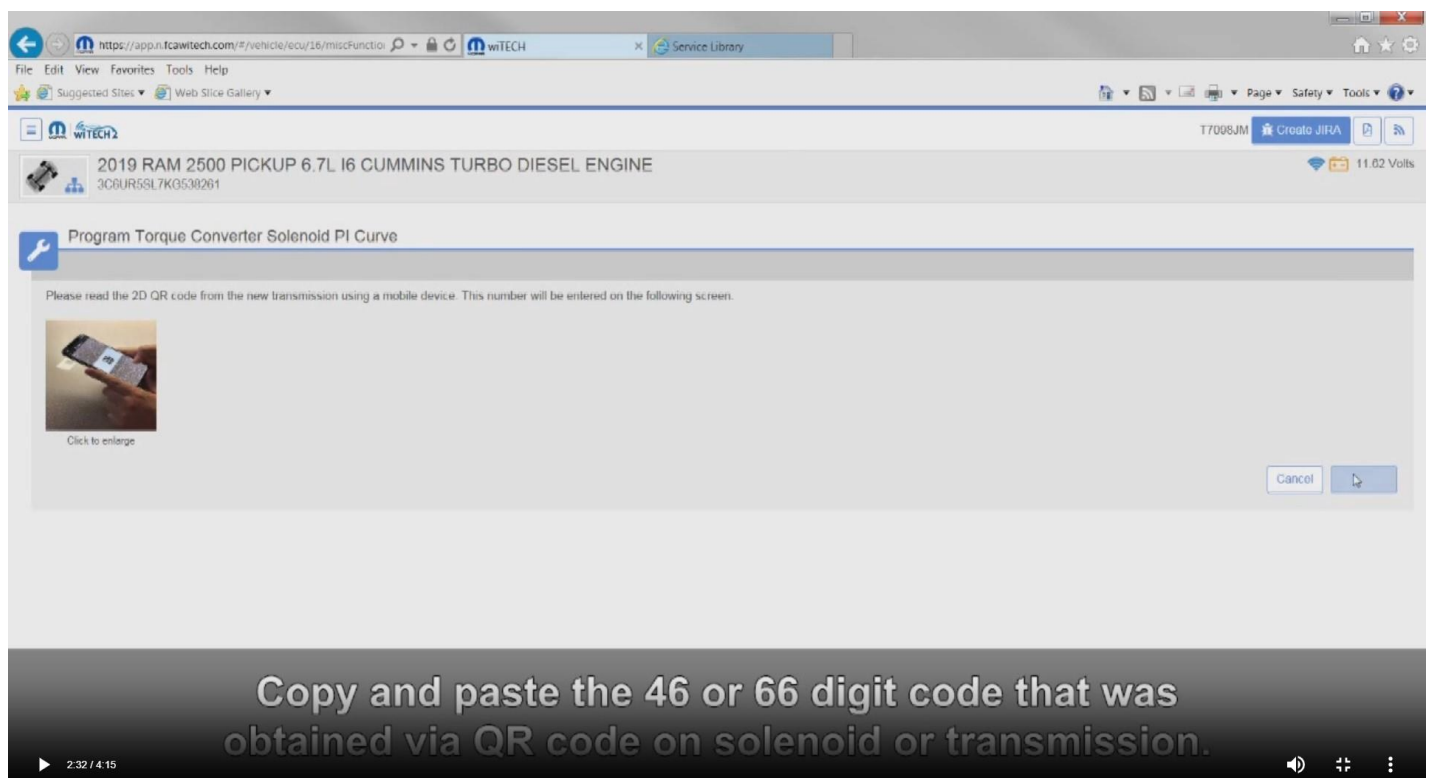

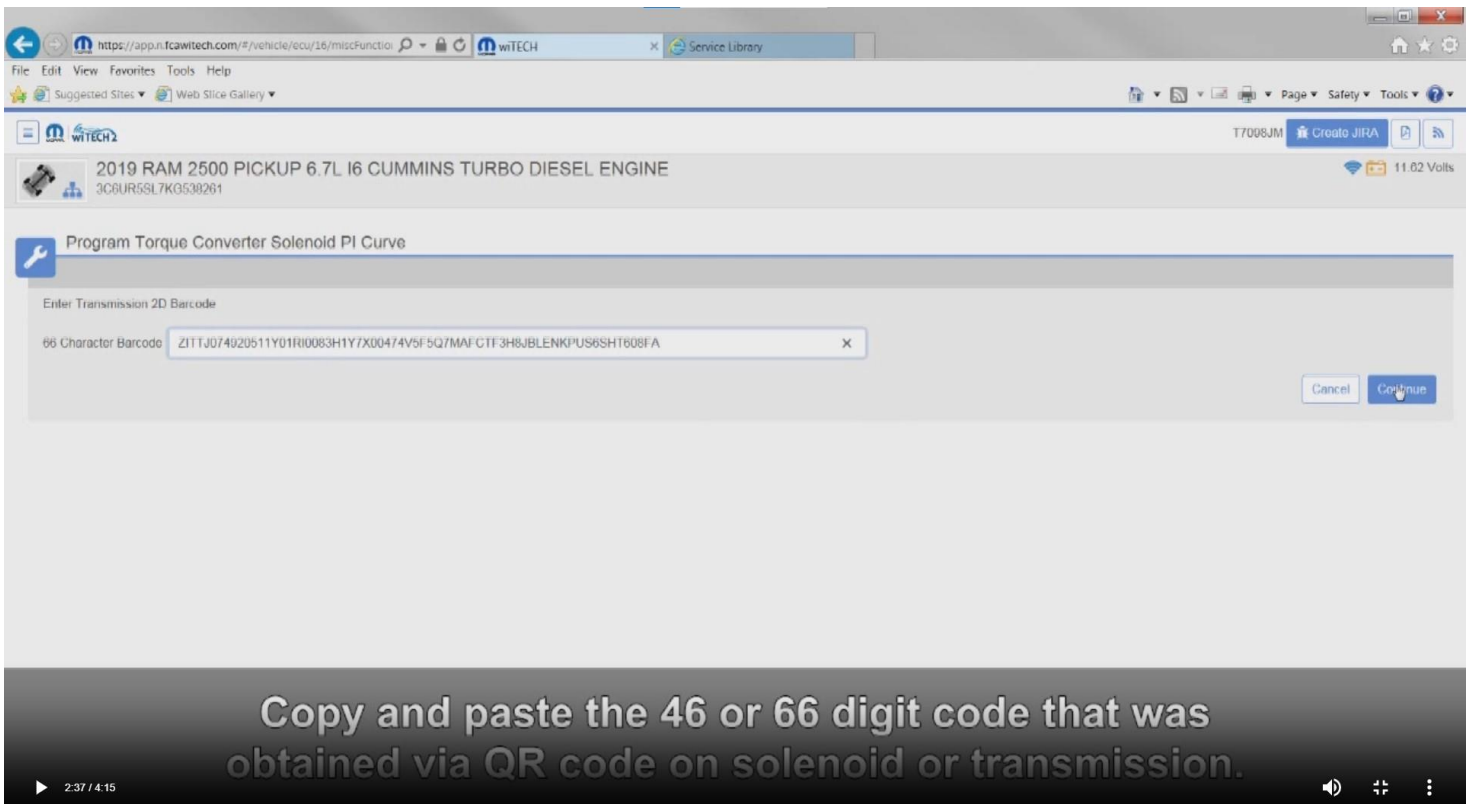

https://app.n.fcawitech.com/#/vehicle/ecu/16/miscFunction

Service Library

2019 RAM 2500 PICKUP 6.7L I6 CUMMINS TURBO DIESEL ENGINE
3C6UR5SL7KG538261

T7008JM Create JIRA

11.02 Volts

Program Torque Converter Solenoid PI Curve

Enter Transmission 2D Barcode

66 Character Barcode Z1TTJ074920511Y01R0083H1Y7XD0474V5F5Q7MAFCF3H8JBLENKPU6SHT608FA

Cancel Continue

Copy and paste the 46 or 66 digit code that was obtained via QR code on solenoid or transmission.

5. Perform Quick Learn by following the instructions in scan tool and clear DTCs.

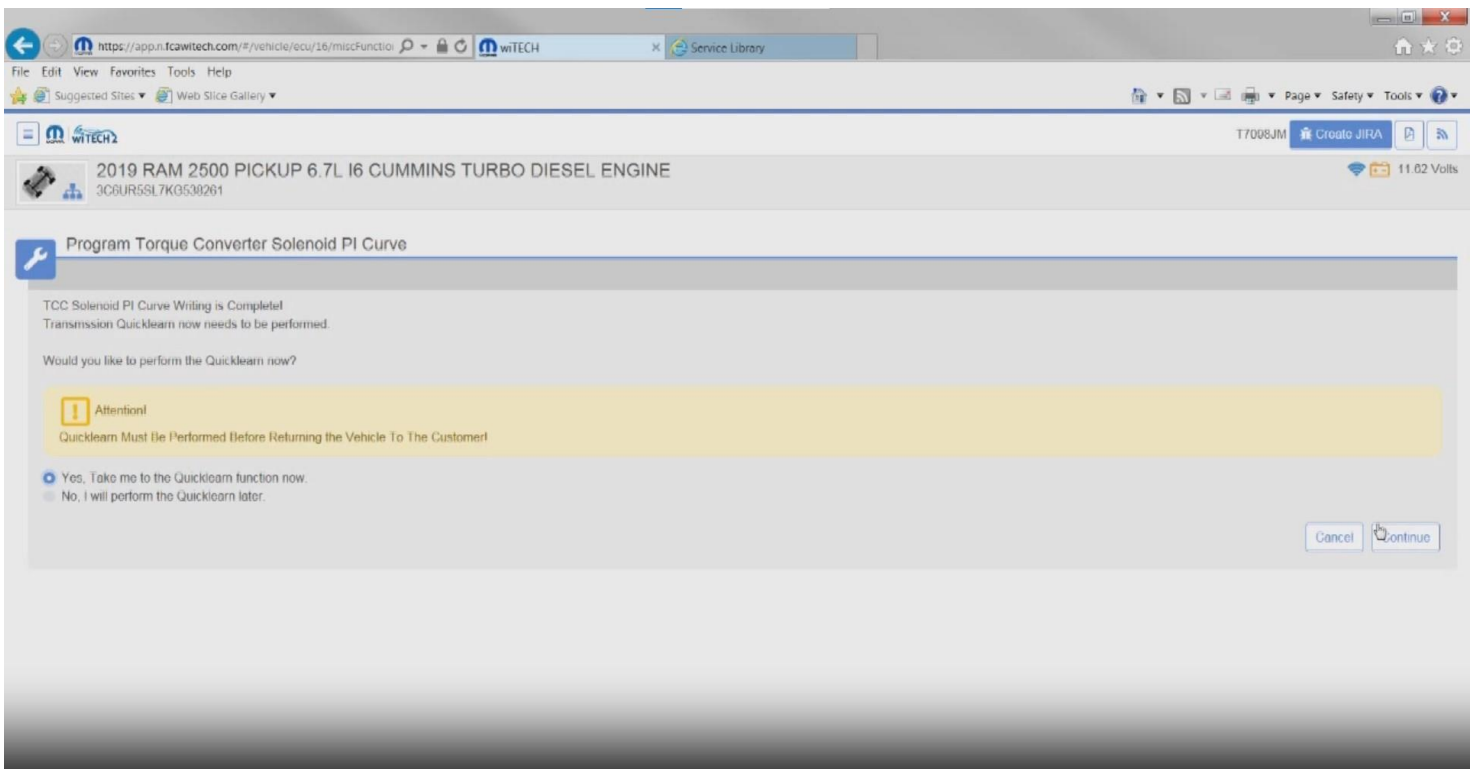

https://app.n.fcawitech.com/#/vehicle/ecu/16/miscFunction

Service Library

2019 RAM 2500 PICKUP 6.7L I6 CUMMINS TURBO DIESEL ENGINE
3C6UR5SL7KG538261

T7008JM Create JIRA

11.02 Volts

Program Torque Converter Solenoid PI Curve

TCC Solenoid PI Curve Writing is Complete!
Transmission Quicklearn now needs to be performed.

Would you like to perform the Quicklearn now?

Attention!
Quicklearn Must Be Performed Before Returning the Vehicle To The Customer!

Yes, Take me to the Quicklearn function now.
 No, I will perform the Quicklearn later.

Cancel Continue

Copy and paste the 46 or 66 digit code that was obtained via QR code on solenoid or transmission.

Select QUICK LEARN from the special function menu. If your scan tool does not have the QUICK LEARN function STOP. Do not drive vehicle. You will not be able to complete installation.

Follow the instruction on the scan tool. The transmission will engage the various clutches to determine base CVI values and will clear its adaptive learning history.

BEFORE you drive the vehicle, record the new CVI values on your warranty sheet. The transmission is now ready for drive learning and pressure checks.

On newer model years look for and preform the EMCC reset/relearn. This will reset the learn of the torque converter.



See BD Diesel YouTube video for more information on this procedure. Check out the Introduction section above for YouTube links!

Road Test and Pressure Checks

Before leaving for the road test, verify transmission pressures. If transmission pressures idle pressure are not as expected do not test drive vehicle. Re-check fluid level, check for fault codes or unplugged sensors. Call BD tech support for assistance.

Mainline Pressures (68 RFE)	
At Idle	Wide Open Throttle
60-120 psi	250 psi

Line pressure varies depending on load, operating state of the transmission etc. At idle in PARK with foot off the brake 60psi is expected. Applying the brake or shifting into gear will yield approximately 120psi.

Do not allow the vehicle to shift at full throttle when obtaining the WOT line pressure check as it will not yet fully relearned. Instead, use the factory tap shifter buttons to prevent shifting above 4th gear. Lightly accelerate until in fourth and in lockup. Then accelerate to WOT in this gear to get a pressure reading.



See BD Diesel YouTube video for more information on this procedure. Check out the Introduction section above for YouTube links!

Drive Learn Procedure

Accelerate with the minimum throttle required when leaving the shop and get onto a quiet stretch of road.

Slowly accelerate the vehicle from first gear up to fourth gear.

Repeat this process a few times until the shift quality becomes consistent. Increase throttle slightly and repeat the procedure.

As shift quality improves, allow truck to shift into 5th and 6th gears also. Generally if gears 1-4 are correctly learned 5th and 6th will shift nicely as they use the same clutches as 2nd and 3rd.

Complete a series of N to D and N to R shifts and verify shift quality is acceptable. See detailed transmission drive learn information below to target specific shifts and for more detailed information.



See BD Diesel YouTube video for more information on this procedure. Check out the Introduction section above for YouTube links!

Final Check and Gauge Removal

After drive learn and pressure checks are complete, bring truck back into shop and remove the transmission pressure gauge adapter.

Use the scan tool to view CVI values and record these on the transmission warranty sheet. Record the pressure readings from the gauge or scan tool as appropriate.

Verify the fluid level now that it is hot and top up if required.

Returning the Vehicle to the Customer

When returning the vehicle to the customer they must be informed the truck is not to be used for heavy towing or hauling until 300 miles of stop and go driving has been completed so that the TCM has time to adjust shift timing correctly.

Go over the warranty statement with them again at this time if not done before and ensure they are aware of the 5000 mile / 8000km first fluid change requirement. See maintenance section at front of manual.

Detailed Relearn Information

You must perform a transmission quick learn, in order for the TCM to recalibrate to the new CVI indexes. This can be accomplished with an OE level scan tool.

The quick learn/drive learn procedure must be performed should any of the following repairs are applied on the vehicle.

- 1) Transmission Replacement
- 2) Transmission Control Module Replacement (TCM)
- 3) Solenoid Pack Replacement
- 4) Clutch Plate and/or Seal Replacement
- 5) Valve Body Replacement or Recondition
- 6) Torque Converter Replacement
- 7) Battery Disconnect or Replacement
- 8) Power Upgrade or Flash Programmer Installation and/or Updates.

A relearn may be caused due to:

- 1) Faulty electrical connection
- 2) Sensor failure

68RFE Transmission Learn Procedure

Once the transmission is installed and full of fluid a scan tool must be connected. The first step is to locate the TCM or ECM Reset and complete the test. Next locate the Clutch Fill Volume Index (CVI) values in the data section of the Transmission Control Module (TCM). This data is in the Powertrain Control Module (PCM) on 2010-12 models. Record these values on the data sheet provided. Next a Quick Learn will need to be performed. This test will be located in the MISC section of the TCM or PCM. After the Quick Learn has completed, the CVI values will need to be recorded again.

Now you are ready for the initial test drive. It is imperative on this test drive not to accelerate aggressively. Bring the vehicle up to normal operating temperature. Try to locate a long level stretch of road with very little to no traffic. To initiate the first part of the drive learn bring the vehicle to a complete stop, place the transmission into reverse gear for 2-3 seconds and then back into drive. While watching throttle percentage accelerate holding a 15 degree throttle angle through the 1-2, 2-3 and 3-4 upshifts and bring the vehicle back to a stop. Now repeat the acceleration and upshift procedure at least 2-4 times before the next reverse or park gear selection. This complete procedure needs to be repeated until the CVI values stabilize (stop changing during shifts). When the CVI values have stabilized the drive learn can process is now ready for some heavier throttle upshifts. The vehicle should be accelerated from a stop at a 30 degree throttle angle through all gears to verify quick clean shifts. **If any stumble, chatter, clunking is felt repeat the initial drive learn test again to re-stabilize the CVI values.** When upshifts are feeling quick and crisp the vehicle can be accelerated at a higher and higher throttle percentage through all gears until 50-60 percent throttle is reached.

If at any time the transmission upshifts become irregular initial drive learn procedure will need to be applied.

After the drive learn is complete and the transmission is shifting correctly a final recording of the CVI values should be entered on to data sheet provided. As well any particularly objectionable shifts can be fine-tuned by following the applicable procedure below.

At this time vehicle can be released to customer to complete break in period.

NOTE: It is not necessary to perform the complete Drive Learn procedure every time the TCM is Quick Learned. Perform only the portions which target the objectionable shift.

LEARN A SMOOTH 1ST NEUTRAL TO DRIVE SHIFT

Perform this procedure only if the complaint is for a delayed or harsh shift the first time the transmission is put into gear after the vehicle is allowed to set with the engine not running for at least 10 minutes. Use the following steps to have the TCM learn the 1st N-D UD CVI.

NOTE: The transmission oil temperature must be between 80 - 110°F (27 - 43°C).

Start the engine only when the engine and ignition have been off for at least ten (10) minutes. With the vehicle at a stop and the service brake applied, record the 1st N-D UD CVI while performing a Neutral to Drive shift. The 1st N-D UD CVI accounts for air entrapment in the UD clutch that may occur after the engine has been off for a period of time. Repeat 1 and 2 until the recorded 1st N-D UD CVI value stabilizes.

NOTE: It is important that this procedure be performed when the transmission temperature is between 80 - 110°F (27 - 43°C). If this procedure takes too long to complete fully for the allowed transmission oil temperature, the vehicle may be returned to the customer with an explanation that the shift will improve daily during normal vehicle usage. The TCM also learns at higher oil temperatures, but these values (line pressure correction values) are not available for viewing on the scan tool.

LEARN A SMOOTH NEUTRAL TO DRIVE GARAGE SHIFT

Perform this procedure if the complaint is for a delayed or harsh shift when the transmission is put into gear after the vehicle has had its first shift. Use the following steps to have the TCM learn the Norm N-D UD CVI.

NOTE: The transmission oil temperature must be between 80 - 110°F (27 - 43°C) to learn the UD CVI. Additional learning occurs at temperatures as low as 0°F and as high as 200°F. This procedure may be performed at any temperature that experiences poor shift quality. Although the UD CVI may not change, shift quality should improve.

Start the vehicle engine and shift to drive.

Move the vehicle forward to a speed of at least 16 km/h (10 MPH) and come to a stop. This ensures no air is present in the UD hydraulic circuit.

Perform repeated N-D shifts at a stop while pausing in Neutral for at least 2-3 seconds and monitor Norm N-D UD CVI volume until the value stabilizes. The value will change during the N-D shift. This is normal since the UD value is different for the N-D shift than the normal value shown which is used for 4-3 coastdown and kickdowns. Perform repeated shifts in this temperature range until the Norm N-D UD CVI value stabilizes and the N-D shifts become smooth.

LEARN THE 1ST 3-4 SHIFT AFTER A RESTART OR SHIFT TO REVERSE

Use the following steps to have the TCM learn the 1st 3-4 shift OD CVI.

NOTE: The transmission oil temperature must be above 80°F (27°C).

With the vehicle engine running, select reverse gear for over 2 seconds.

Shift the transmission to Drive and accelerate the vehicle from a stop at a steady 15 degree throttle opening and perform a 3-4 shift while noting the 1st 3-4 OD CVI.

Shift the transmission to Drive and accelerate the vehicle from a stop at a steady 15 degree throttle opening and perform a 3-4 shift while noting the 1st 3-4 OD CVI.

Repeat 1 and 2 until the 1st 3-4 upshift becomes smooth and the 1st 3-4 OD CVI stabilizes.

LEARN A SMOOTH 3-4 AND 4-5 UPSHIFT

NOTE: The transmission oil temperature must be above 110°F (43°C).

Use the following steps to have the TCM learn the OD and 4C CVI's.

Accelerate the vehicle from a stop at a steady 15 degree throttle opening and perform multiple 1-2, 2-3, 3-4 and 4-5 upshifts. The 2nd 3-4 shift following a restart or shift to reverse will be shown during the shift as a value between the 1st 3-4 OD CVI and the normal OD CVI. Updates to the normal OD CVI will occur after the 2nd shift into 4rd gear, following a restart or shift to reverse.

Repeat 1 until the 3-4 and 4-5 shifts become smooth and the OD and 4C CVI become stable.

LEARN A SMOOTH 5-4 COASTDOWN AND PART THROTTLE 5-4 KICKDOWN

NOTE: The transmission oil temperature must be above 110°F (43°C).

Use the following steps to have the TCM learn the UD shift volume.

At a vehicle speed between 64-97 km/h (40-60 MPH), perform repeated 5-4 kickdown shifts.

Repeat 1 until the UD volume becomes somewhat stable and the shift becomes smooth.

LEARN A SMOOTH 1-2 UPSHIFT AND 3-2 KICKDOWN

Use the following steps to have the TCM learn the 2C shift volume.

NOTE: The transmission oil temperature must be above 110°F (43°C).

With a vehicle speed below 48 km/h (30 MPH) and the transmission in 3rd gear, perform multiple 3-2 kickdowns.

Repeat 1 until the 3-2 kickdowns become smooth and the 2C CVI becomes stable.

LEARN A SMOOTH MANUAL 2-1 PULLDOWN SHIFT AS WELL AS A NEUTRAL TO REVERSE SHIFT

NOTE: The transmission oil temperature must be above 110°F (43°C).

Use the following steps to have the TCM learn the LR volume.

With the vehicle speed around 40-48 km/h (25-30 MPH) in Manual 2nd, perform manual pulldowns to Low or 1st gear at closed throttle.

Repeat 1 until the LR CVI becomes stable and the manual 2-1 becomes smooth.

LEARN A SMOOTH NEUTRAL TO REVERSE SHIFT

NOTE: The transmission oil temperature must be above 110°F (43°C).

With the vehicle at a stop, perform Neutral to Reverse shifts until the shift is smooth. An unlearned Neutral to Reverse shift may be harsh or exhibit a double bump.

If any of the shifts are still not smooth after the clutch volume stabilizes, an internal transmission problem may be present.

LEARN A SMOOTH 5-6 UPSHIFT

NOTE: The transmission oil temperature must be above 110°F (43°C).

Use the following steps to have the TCM learn the Alt 2C CVI.

Accelerate the vehicle through 88 km/h (55mph) at a steady 10-15 degree throttle opening and perform multiple 5-6 upshifts.

Repeat 1 until the 5-6 shift become smooth and the Alt 2C CVI become stable. There is a separate 2C volume used and learned for 5-6 shifts, 2CA. It is independent of the 2C CVI learned on 3-2 kickdowns.

Solenoid Pack Field Replacement

If you must replace your transmissions solenoid pack, beware that BD Diesel transmissions use a different solenoid pack than stock transmissions for 2011-2018 vehicles.

You must use the 2008-2010 universal solenoid pack (Chrysler part number **68353383AB**) identified by the **white** connector, and not the “correct” solenoid pack for your vehicle.

Your transmission may have come with a gray solenoid pack connector that has been painted white. These solenoid packs have been modified by BD to be functionally equivalent to the white solenoid packs.

2019-2022 Models: If replacing the Valve Body/Solenoid Pack/TCC Solenoid on a 2019-2022 transmission, make sure to scan and save the new TCC Solenoid’s PI Curve information from the QR Code matrix on the solenoid and enter it into the scan tool’s ‘Program Torque Converter Solenoid PI Curve’ under Misc functions menu for updating the PCM. Also make sure to remove the old TCC solenoid’s QR code stickers if present on the transmission body.

Troubleshooting

Truck sets a P0868 Low Line Pressure fault code

Code present at idle

- Indicates a pressure module issue or connection issue
- Temporarily remove BD pressure box, clear code and retest to confirm if it is a pressure box issue. With the BD module removed the truck should run stock pressures.

Code present at WOT

- Possible connector issue or module issue
- If no problems found with connector, attach mechanical gauge and compare pressure on scan tool to mechanical gauge at WOT. If pressure is below 230psi it is likely there is an issue with the transmission cooler causing reduced flow. If replacing the cooler does not remedy this, contact BD.

Truck sets a P0871 Transmission Fluid Pressure fault code

Code present after solenoid pack replacement

- BD Diesel transmissions use a different solenoid pack than stock transmissions for 2011-2018 vehicles. You must use the 2008-2010 universal solenoid pack (Chrysler part number **68353383AB**) identified by the **white** connector, and not the “correct” solenoid pack for your vehicle.

Transmission Cooler Check

Disconnect cooler line and verify cooler flow rate. At idle it should be a minimum of 1.5GPM. You can use a clean bucket to drain into for this test. If it does not meet the requirement you will need to replace your cooler and check valve assembly.