



AEROMOTIVE
Part # 11803
01-10 CHEVY/GMC Duramax Fuel System Kit
RETRO FIT KIT FOR 1/2" LINES
INSTALLATION INSTRUCTIONS

CAUTION:

Installation of this product requires detailed knowledge of automotive systems and repair procedures. We recommend that this installation be carried out by a qualified automotive technician.

Installation of this product requires handling of diesel. Ensure you are working in a well ventilated area with an approved fire extinguisher nearby. Extinguish all open flames, prohibit smoking and eliminate all sources of ignition in the area of the vehicle before proceeding with the installation.

When installing this product, wear eye goggles and other safety apparel as needed to protect yourself from debris and sprayed diesel.

Aeromotive system components are not legal for sale or use on emission controlled motor vehicles.

This kit contains the following parts:

1 ea Frame Bracket 1	1 ea Pump Power Harness
1 ea Frame Bracket 2	4 ea P/N 15129 AN10 to 1/2" J2044 Quick Connect
2 ea 2" Bracket Spacers	1 ea P/N 15131 AN12 to 1/2" J2044 Quick Connect
1 ea Fuel Pump Assembly (130gph)	1 ea 15632 0-15psi, 1/8" npt, Fuel Pressure Gauge
1 ea 1/2" Suction Hose Assembly	3 ea 3/8-16 Zinc Plated Jam nut
3 ea 3/8-16 x 4" Hex Head Bolt	4 ea AN-10 o-ring
2 ea 3/8-16 x 3" Tapered Socket Cap Screw	1 ea AN-12 o-ring
3 ea Zinc Plated Lock Washer	1 ea P/N 12324 100 micron pre-filter

PUMP SPECS:

Regulator Adjustment Pressure Range:	2-20psi
Flow Output @ 13.5V:	130gph @ 10psi
Filter Micron Rating:	2 Micron (CATERPILLAR 1R-0750)
Coolant Ports:	AN-08 ORB
Inlet Port:	AN-12 ORB
Outlet/Return Port:	AN-10 ORB
Filter Threads:	1"-14
Factory Pressure setting:	10 psi
Gauge Port:	1/8" NPT

NOTE: This system is designed to replace a diesel lift that is already installed on a vehicle using the 1/2" J2044 connectors. If you do not have this style of connector please call Aeromotive's Tech department 913-647-7300.

WARNING: DO NOT REVERSE POLARITY ON PUMP! FUEL PUMP DAMAGE WILL ACCUR.

WARNING!



Always be aware of flammable situations. Drilling and grinding can be potential ignition sources. Extinguish all open flames, prohibit smoking and eliminate all sources of ignition in the area of the vehicle and workspace before proceeding with the installation. Ensure you are working in a well ventilated area with an approved fire extinguisher nearby.

WARNING!



Installation of this product requires modification to a fuel tank, failure to satisfy all safety considerations will result in fire, explosion, injury and/or loss of life to yourself and/or others.

WARNING!



Mechanical and hydraulic lifting devices can tip over or lower accidentally due to incorrect maneuvering or technical errors. A falling object can cause injury and/or loss of life to yourself and/or others. When working under the vehicle always use stands and ensure that the ground or floor is stable and level. Never crawl under a vehicle which is only supported by a jack.

CAUTION:



Make sure all batteries are disconnected before starting installation. Most diesel truck have two 12v batteries.

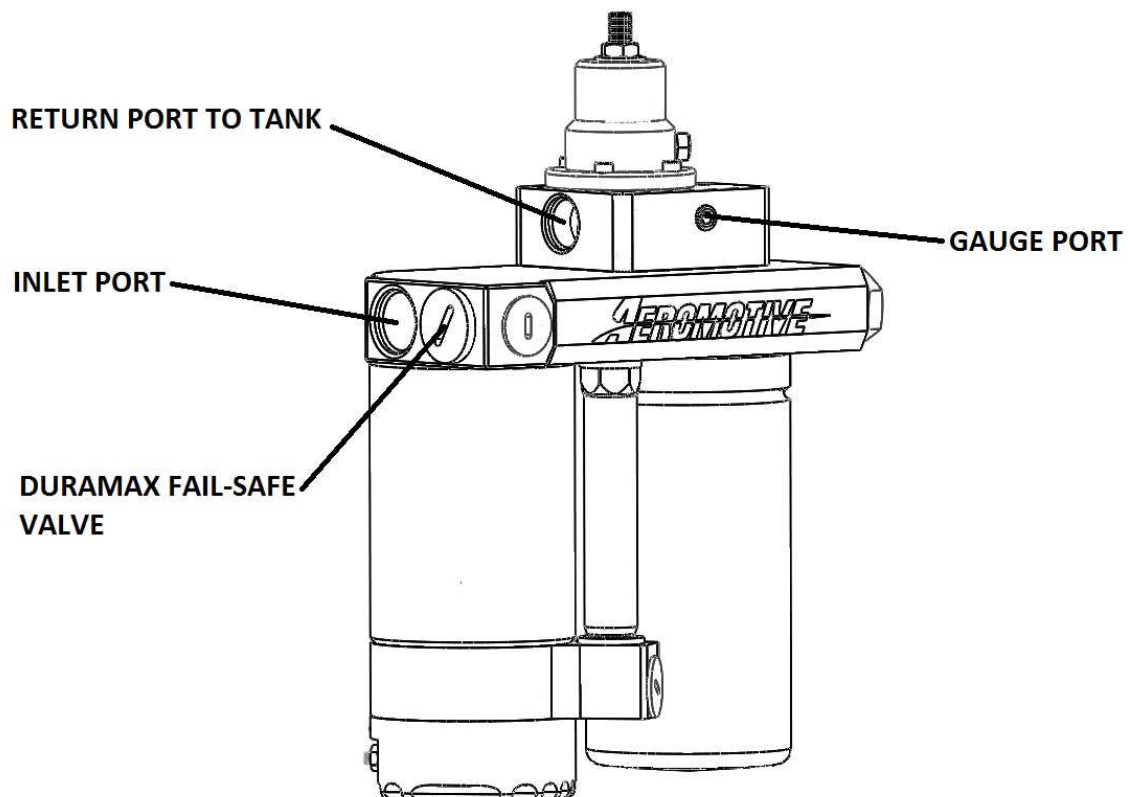

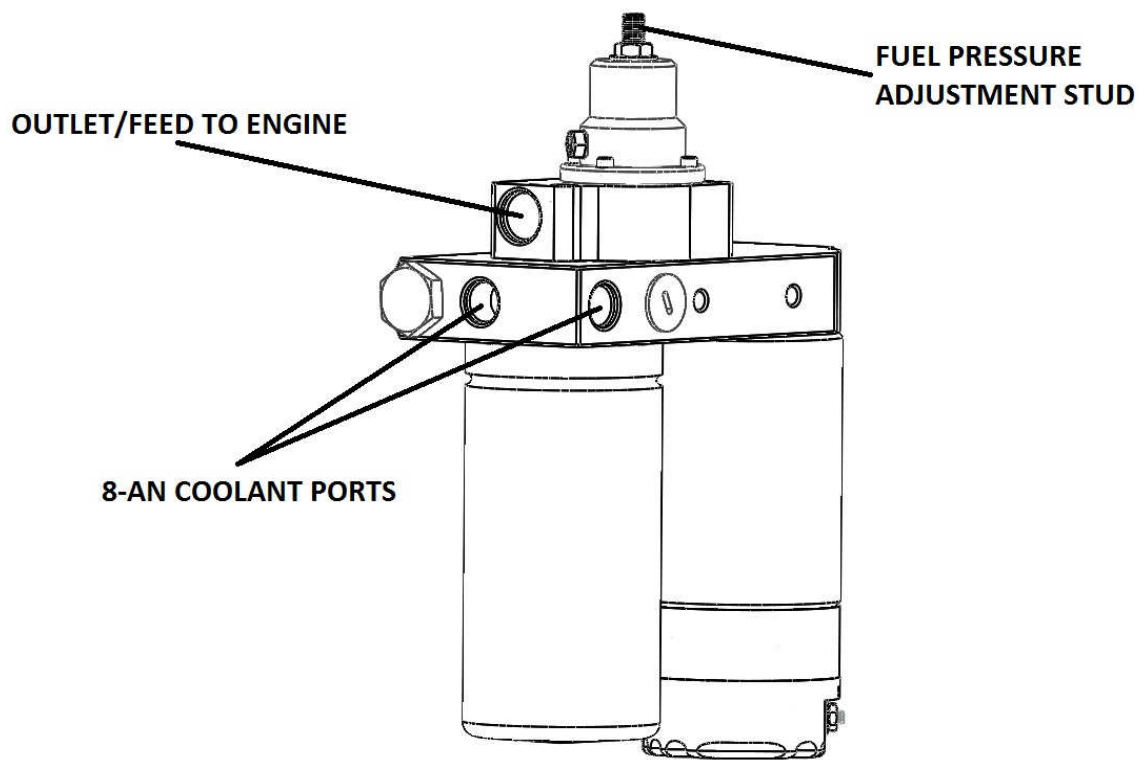

1. Locate the existing lift pump mounted on the frame rail and remove it along with the brackets. Leave all wiring and hoses in place as these will be reused.
2. Assemble the bracket to the frame as illustrated in **FIGURE 1-1**. Use the 3/8" x 4" bolt, lock washers and nuts.

NOTE: When installing the top bolts in the mounting plate, be sure not to pinch any tubes or wiring between the plate and frame.

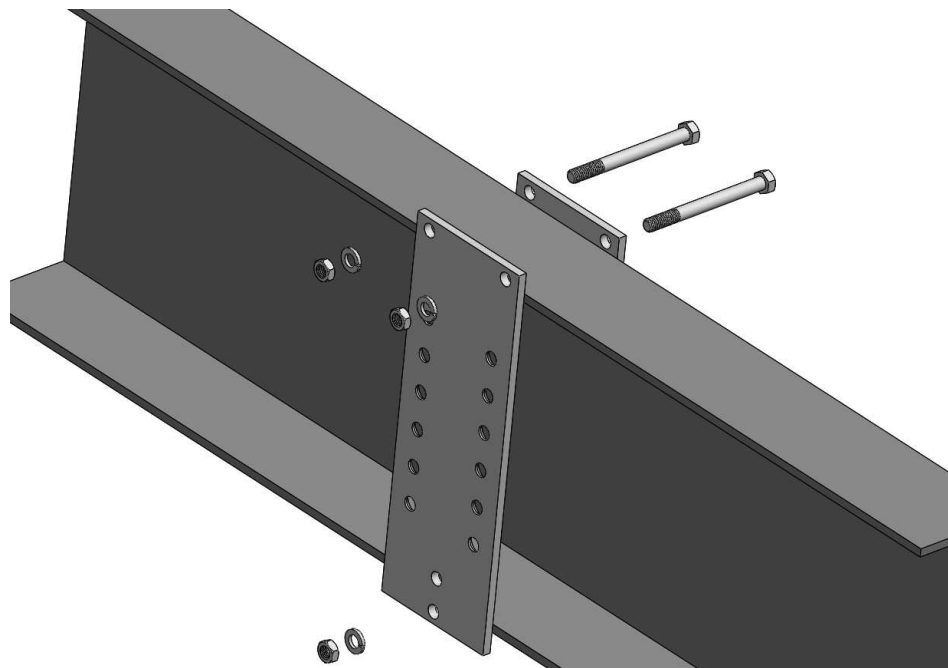

FIGURE 1-1

3. Choose the holes that best set the pump height closest to the floor pan. This will allow maximum clearance for road debris (on or off road). Feed the tapered head 3/8" bolts thru the back side of the bracket. **FIGURE 1-2**

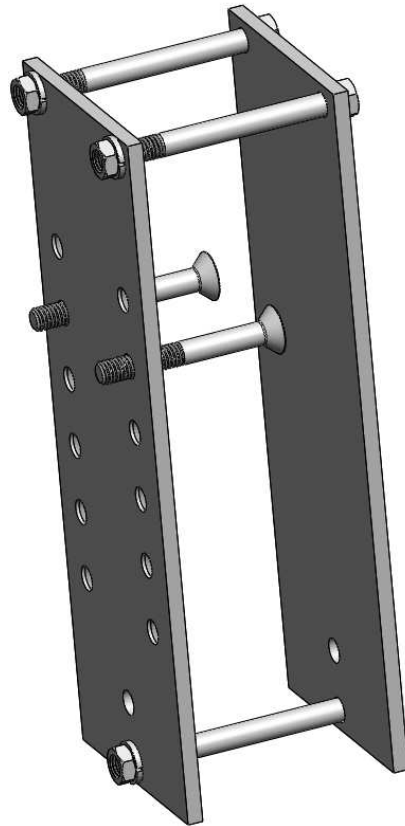

FIGURE 1-2

4. Slide the two spacers over the two bolts to space the pump away from the frame and wiring. Now tighten the pump to the bracket. **FIGURE 1-3**

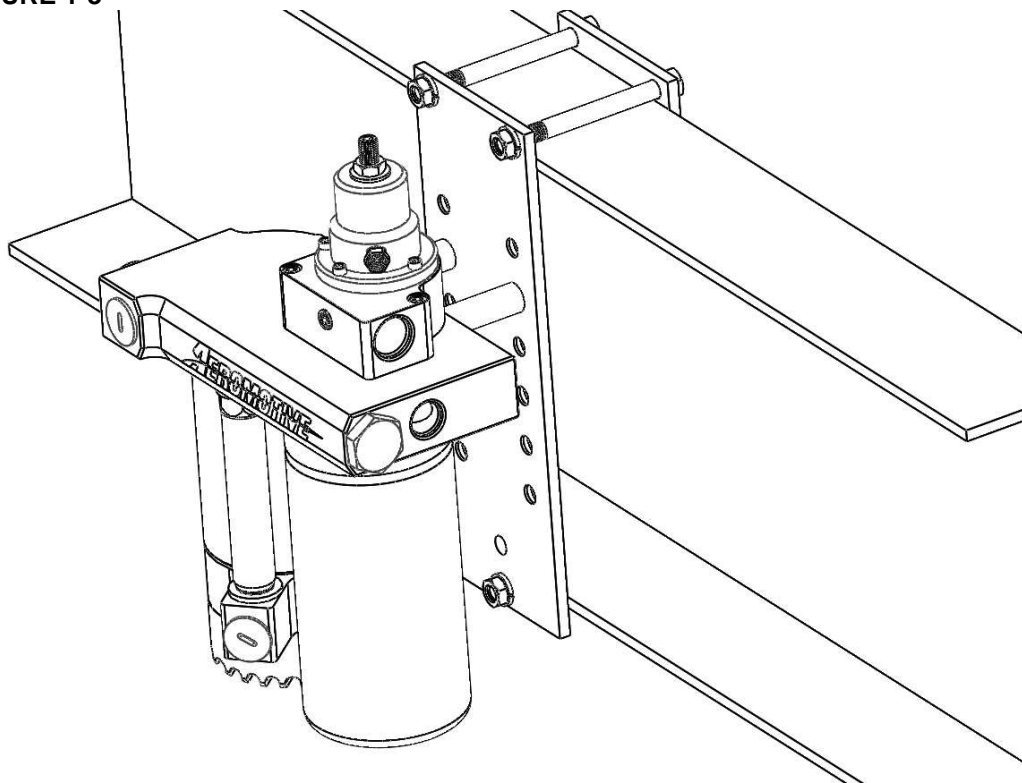

FIGURE 1-3

5. Screw the three port fittings into the pump. Ensure that the fitting have the o-rings installed on them. If not, do that at this time. **FIGURE 1-4**

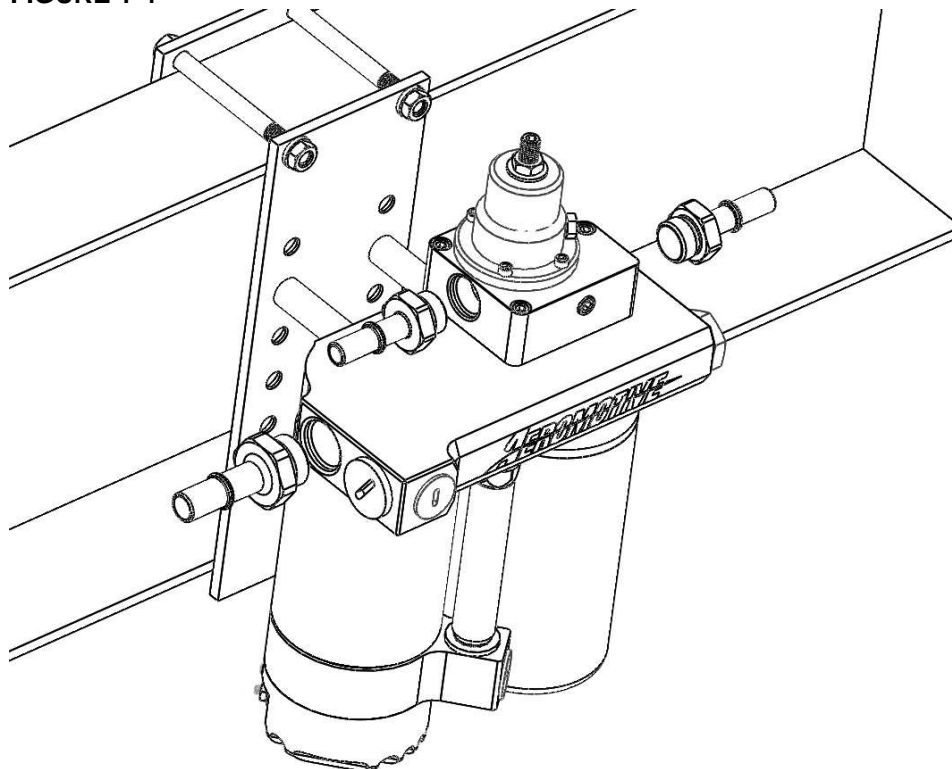

FIGURE 1-4

6. Connect the return and engine feed lines back to the Aeromotive pump.
7. Assemble the 12" section of suction line with the included filter fittings (make sure fitting have o-rings installed on them). **FIGURE 1-5**

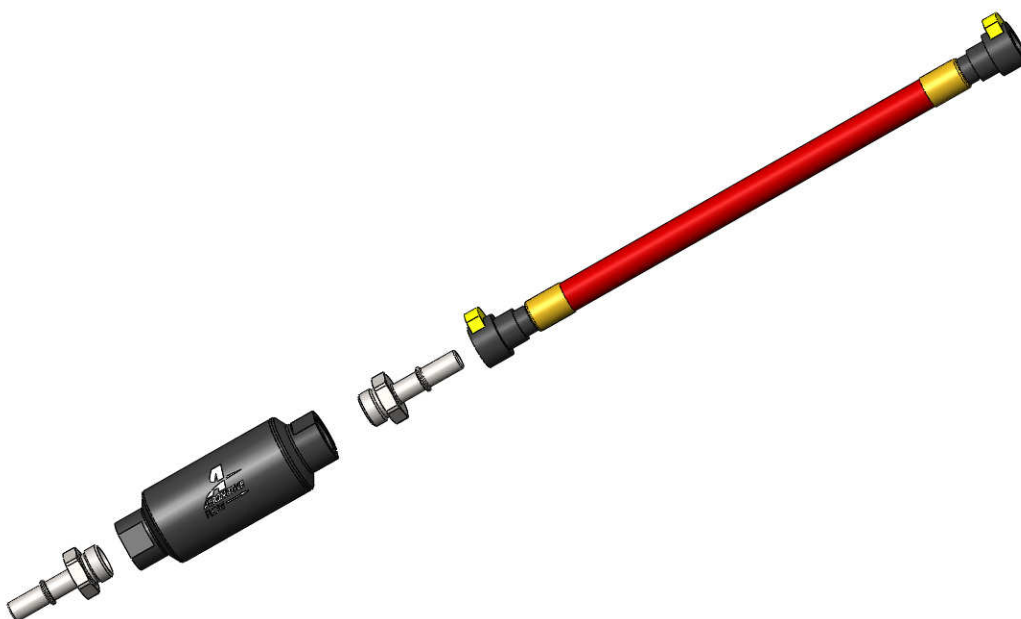

FIGURE 1-5

8. Attach the filter line assembly to the fuel pump inlet. **FIGURE 1-6**

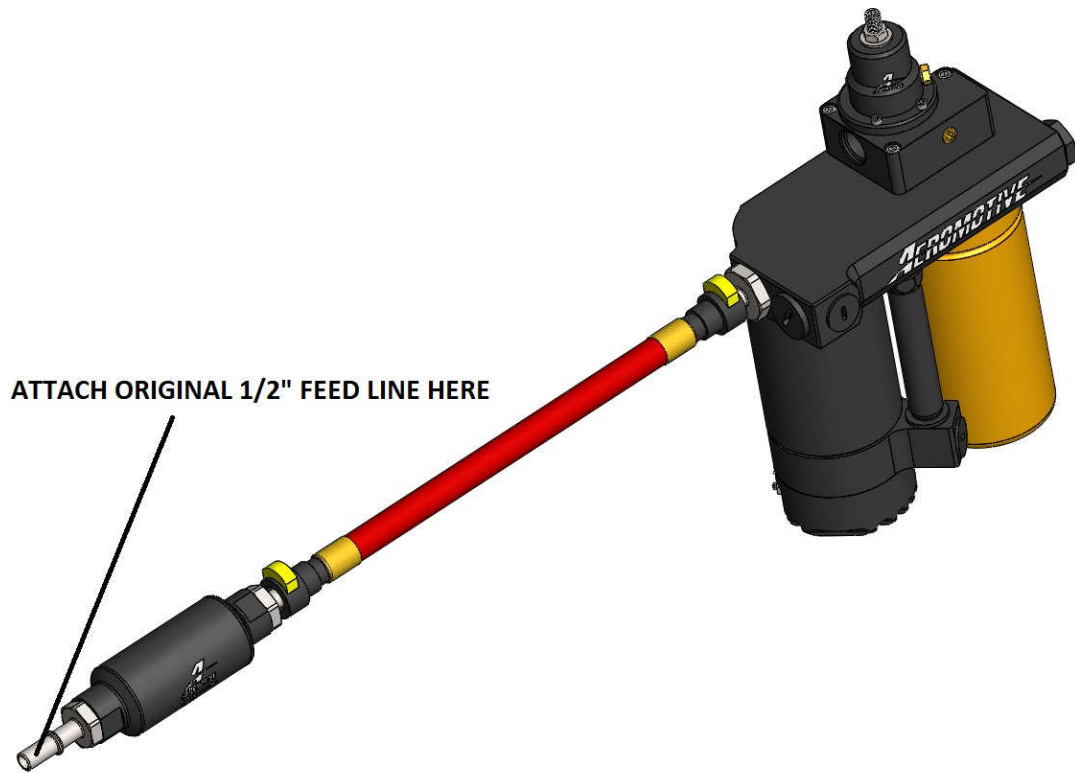

FIGURE 1-6

9. Using the supplied wiring pig tail, connect it to the old wiring harness.
10. Attach the provided fuel pressure gauge to the gauge port on the pump. **FIGURE 1-7**

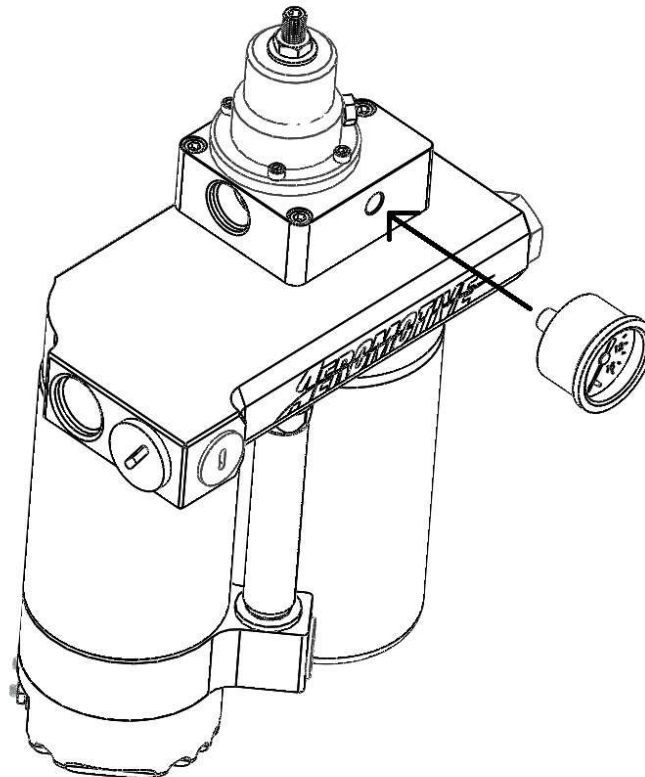

FIGURE 1-7

11. The system is now ready to prime. The Aeromotive diesel lift pump is a self priming system and does not require you crack or bleed any part of the system. Turn the key to the "on" position. Verify the pump is running by checking the fuel pressure gauge (pressure is pre-set at 10psi). Check for leaks at this time.
12. If you wish to adjust pressure you can do that at anytime. Loosen the jam nut on the top of the regulator and turn the adjusting stud to adjust pressure. Clockwise raises pressure while counterclockwise lowers.
13. Start the vehicle and verify all connections are leak free.

FILTER CROSS REFERENCE

Part #	Manufacturer	Thread Size 1"-14	
		Description	Micron Rating
BF1258	Baldwin	Fuel/Water Separator	10 Micron
BF1212	Baldwin	Fuel/Water Separator	
BF1214	Baldwin	Fuel/Water Separator	
175-2949	CAT	Fuel/Water Separator	
1R-0750	CAT	Fuel Filter	2 Micron
P551000	Donaldson	Fuel/Water Separator	10 Micron
P551001	Donaldson	Fuel/Water Separator	20 Micron
P558000	Donaldson	Fuel/Water Separator	20 Micron
FS1000	Fleetguard	Fuel/Water Separator	10 Micron
FS1001	Fleetguard	Fuel/Water Separator	10 Micron
FS1009	Fleetguard	Fuel/Water Separator	14 Micron
FS1212	Fleetguard	Fuel/Water Separator	14 Micron
LFF1223	Luber Finer	Fuel/Water Separator	
LFF8000	Luber Finer	Fuel/Water Separator	
3406	Napa	Fuel/Water Separator	14 Micron
3407	Napa	Fuel/Water Separator	5 Micron
3405	Napa	Fuel/Water Separator	14 Micron
33407	WIX	Fuel/Water Separator	5 Micron
33115	WIX	Fuel Filter	10 Micron
33504	WIX	Fuel/Water Separator	14 Micron

AEROMOTIVE, INC. LIMITED WARRANTY

This Aeromotive Product, with proof of purchase dated on or after January 1, 2003, is warranted to be free from defects in materials and workmanship for a period of one year from the original date of purchase. No warranty claim will be valid without authentic, dated proof of purchase.

This warranty is to the original retail purchaser and none other and is available directly from Aeromotive and not through any point of distribution or purchase.

If a defect is suspected, the retail purchaser must contact Aeromotive directly to discuss the problem, possible solutions and obtain a Return Goods Authorization (RGA), if deemed necessary by the company. Please call 913-647-7300 and dial option 3 for the technical service dept. All returns must be shipped freight pre-paid to the company and with valid RGA before they will be processed.

Aeromotive will examine any product returned with the proper authorization to determine if the failure resulted from a defect or from abuse, improper installation, misapplication or alteration. Aeromotive will then, at it's sole discretion, return, repair or replace the product.

If any Aeromotive product is determined defective, buyer's exclusive remedy is limited in value to the sale price of the good. In no event shall Aeromotive be liable for incidental or consequential damages.

Aeromotive expressly retains the right to make changes and improvements in any product it manufactures and sells at any time. These changes and improvements may be made without notice at any time and without any obligation to change the catalogs or printed materials.

Aeromotive expressly retains the right to discontinue at any time and without notice any Aeromotive product that it manufactures or sells.

This warranty is limited and expressly limits any implied warranty to one year from the date of the original retail purchase on all Aeromotive products.

No person, party or corporate entity other than Aeromotive shall have the right to: determine whether or not this Limited Warranty is applicable to any Aeromotive product, authorize any action whatsoever under the terms and conditions of this Limited Warranty, assume any obligation or liability of any nature whatsoever on behalf of Aeromotive under the terms and conditions of this Limited Warranty.

This Limited Warranty covers only the product itself and not the cost of installation or removal.

This Limited Warranty is in lieu of and expressly excludes any and all other warranties, expressed or implied. This Limited Warranty gives you specific legal rights, and you may also have other rights which vary from state to state.