



**Read installation instructions completely before installing.**

**INSTALLATION INSTRUCTIONS**

Congratulations—your new suspension helpers are quality products capable of improving the handling and comfort of your vehicle while under load. As with all products, proper installation is the key to obtaining all of the benefits your kit is capable of delivering. Please take a few minutes to read through the instructions to identify the components and learn where and how they are used. It is a good idea to start by comparing the parts in your kit with the parts list below.

**NOTE: IF ANY PARTS ARE MISSING FROM THE KIT, PLEASE CALL 1-800-888-0650.**

**PLEASE DO NOT CALL OR RETURN THE KIT TO THE DEALER.**

Be sure to take all applicable safety precautions during the installation of the kit. The instructions listed in this brochure and the illustrations all show the left, or driver’s side of the vehicle. To install the right side assembly simply follow the same procedures.

**VEHICLE PREPARATION**

With the vehicle on a solid level surface, chock the front wheels and raise the vehicle using a jack rated for your vehicle’s weight. Lift the wheels off the ground. Lower the vehicle frame onto jack stands rated for your vehicles

**WARNING**

Do not inflate this assembly when it is unrestricted. The assembly must be restricted by a coil spring. Do not ever inflate beyond recommended operating pressures for your specific vehicle. Improper use or over inflation may cause property damage or severe personal injury.

weight making sure the suspension is fully extended. (Do NOT use wood or concrete blocks to support the weight of the vehicle.) Remove the jounce bumpers located under the frame rail, by prying them out of the jounce bumper cup. The jounce bumpers will not be re-used with this kit but the bolts will be reused.

**SHOCK ABSORBERS**

If necessary, additional clearance between the coil turns may be obtained by removing the shock absorbers from the lower shock mounts and lowering the suspension an additional one to two inches. (CAUTION: Do not put strain or tension on the flexible brake line.)

**OPERATING PRESSURES:**

<b>MINIMUM (UNLOADED)</b>	<b>5 PSI</b>
<b>MAXIMUM (LOADED)</b>	<b>70 PSI</b>

**PARTS LIST**

**BOLT PACK**

COIL-RITE AIR SPRING	6133	2	INFLATION VALVE	3098	2
COIL-RITE SUPPORT	0045	2	VALVE CAP	3099	2
AIR LINE ASSEMBLY	0048	1	NYLON TIES	9168	6
5/16" WASHERS		4	THERMAL SLEEVE	0899	2

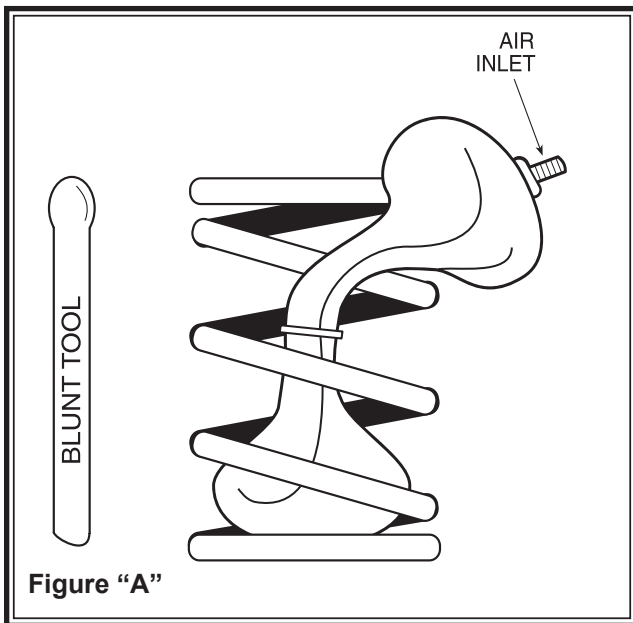

Figure "A"

### STEP 1— AIR SPRING PREPARATION

Remove the inflation valve cap from the inflation valve on the air spring. Using the valve cap as a core tool from the inflation valve, remove the inflation valve core from the air spring. Exhaust the air spring by pushing it flat then re-insert the valve core back into the air spring to keep it collapsed.

### STEP 2—INSTALLING THE AIR SPRING

Insert the top of the flattened air spring into the coil spring through the lowest opening with the inflation valve inlet at the top as shown in *Figure "A"*.

### STEP 3—ADJUSTING THE AIR SPRING

Push the air spring up into the coil spring by hand or with a blunt tool. DO NOT use anything with sharp edges or corners as this may damage the air spring.

When the air spring is completely within the coil spring, remove the valve core to let the air back into the air spring. Allow the air spring to return to its normal shape.

Install the spacer on top of the air spring. *See Figure "B"*. Once the weight of the vehicle is applied to the suspension aid the air springs are pressurized, the spacer will stay in place.

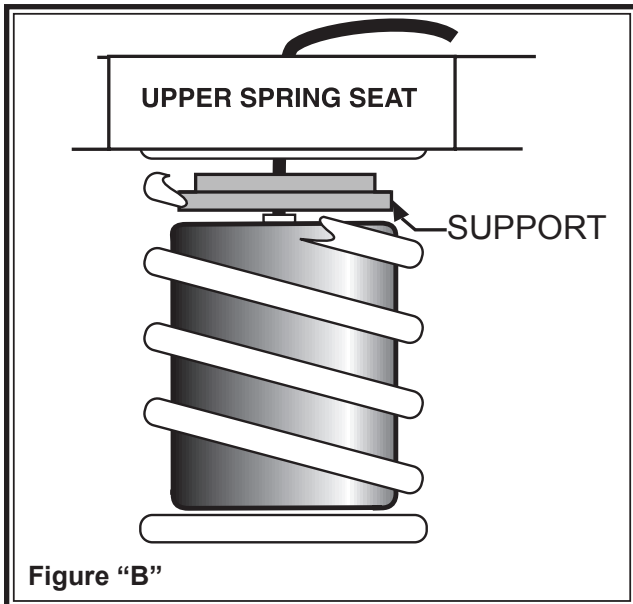

Figure "B"

### STEP 4— REATTACH THE SHOCK ABSORBER

Attach shock absorbers if removed earlier in the installation. Torque to manufactures specifications.

### STEP 5— ROUTE THE AIR LINE

Cut the remaining air line tubing into two equal lengths (cut the tubing as squarely as possible). Select a location for the inflation valves in a protected area, such as the bumper or fuel fill floor (**Note:** The inflation valve will be installed in Step 8).

Screw the fitting that is on the tubing onto the inflation valve coming out of the air spring. Route the tubing from the air spring to the inflation valve, making sure to avoid direct heat from the engine, exhaust pipe and away from sharp edges. Secure with Nylon ties provided in your kit.

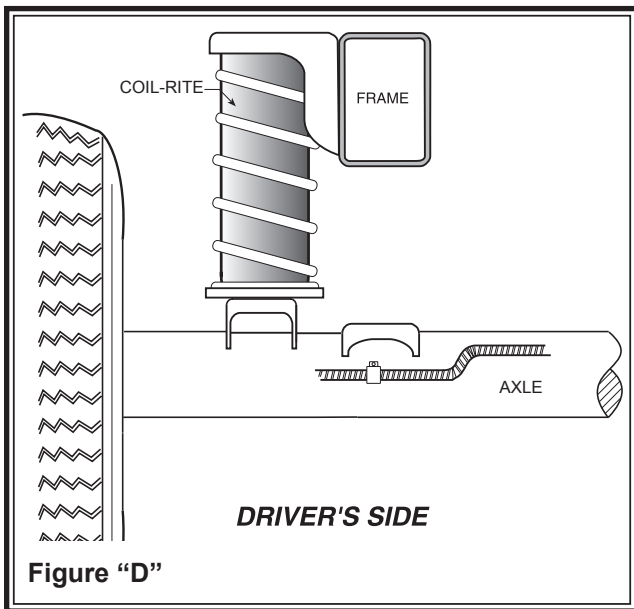

**STEP 8—INSTALL THE AIR LINE AND INFLATION VALVE**

Select a location on the vehicle for the air inflation valves. The location can be located on the bumper or the body of the vehicle, as long as it is in a protected location so the valve will not be damaged, but maintain accessibility for the air chuck **see Figure "E"**. Drill a 5/16" hole and install the air inflation valve using two 5/16" flat washers per valve as supports **see Figure "F"**.

**FOLLOW STEPS 1-8 FOR THE OTHER SIDE OF THE VEHICLE.**

**STEP 9—INFLATE AND TEST**

Inflate the air springs to recommended operating pressure (see page 1 for operating pressures). With a soap and water solution, check for air leaks around the fittings and valve core. We recommend inflating and deflating in 5 psi increments to find the ideal riding condition for your vehicle.

**STEP 10—COMPLETION**

This now completes the installation. Install. Raise the vehicle and remove the jack stands and lower the vehicle back onto the ground. Inflate the Coil-Rite air helper springs to 5 psi.

**NOTE: Check air pressure on a monthly basis.**

