

Owner's Manual with Installation Instructions

Banks Monster[®] Exhaust System

2017+ Ford Power Stroke 6.7L Turbo-Diesel F-250/F-350/F-450 Trucks

THIS MANUAL IS FOR USE WITH SYSTEM 49795, 49795-B
SCSB, CCSB, SCLB, CCLB



Step-by-step installation video:
bankspower.com/v/install-ford67-exhaust

Gale Banks Engineering
546 Duggan Avenue • Azusa, CA 91702
(626) 969-9600 • Fax (626) 334-1743

Product Information & Sales: (888) 635-4565
Customer Support: (888) 839-5600
Installation Support: (888) 839-2700

bankspower.com



General Installation Practices

Dear Customer,

If you have any questions concerning the installation of your Banks Techni-Cooler, please call our Technical Service Hotline at (888) 839-2700 between 7:00 a.m. and 4:00 p.m. (P.T.). If you have any questions relating to shipping or billing, please contact our Customer Service Department at (888) 839-5600.

Thank you.

- 1.** Before starting work, familiarize yourself with the installation procedure by reading all of the instructions.
- 2.** The exploded view (**Figure 1**, pages 4-5) provides only general guidance. Refer to each step and section diagram in this manual for proper instruction.
- 3.** Throughout this manual, the left side of the vehicle refers to the driver's side, and the right side to the passenger's side.
- 4.** Disconnect the negative (ground) cable from the battery (or batteries, if there are two) before beginning work.
- 5.** Route and tie wires and hoses a minimum of 6" away from exhaust heat, moving parts, and sharp edges. Clearance of 8" or more is recommended where possible.
- 6.** When raising the vehicle, support it on properly weight-rated safety stands, ramps or a commercial hoist. Follow the manufacturer's safety precautions. Take care to balance the vehicle to prevent it from slipping or falling. When using ramps, be sure the front wheels are centered squarely on the topsides. When raising the front of the vehicle, put the transmission in

park (automatic) or reverse (manual), set the parking brake, and block the rear wheels. When raising the back of the vehicle, be sure the vehicle is on level ground and the front wheels are blocked securely.

CAUTION! Do not use floor jacks to support the vehicle while working under it. Do not raise the vehicle onto concrete blocks, masonry or any other item not intended specifically for this use.

7. During installation, keep the work area clean. Do not allow anything to be dropped into intake, exhaust, or lubrication system components while performing the installation, as foreign objects will cause immediate engine damage upon start-up.

TOOLS REQUIRED:

- 1/2" and 3/8" drive ratchets with inch and metric sockets and 1/2" and 3/8" drive extension
- Inch and metric combination or open-end wrenches
- Standard screwdriver
- Clean shop towels or rags
- Pry-bar

HIGHLY RECOMMENDED TOOLS AND SUPPLIES:

- Penetrating oil or light lubricant spray



! WARNING!

READ AND UNDERSTAND OWNER'S MANUAL PRIOR TO USE. FAILURE TO FOLLOW WARNINGS COULD RESULT IN **SERIOUS INJURY OR **DEATH**.**

NORMAL OPERATION

Do not park, idle, or drive your vehicle on dry grass or other dry ground cover. The emission system heats up the engine compartment and exhaust system, creating a risk of fire.

The normal operating temperature of the exhaust system is very high. Never work around or attempt to repair any part of the exhaust system until it has cooled. Use special care when working around the diesel oxidation catalytic converter or diesel particulate filter. The diesel oxidation catalytic converter and the diesel particulate filter heat up to very high temperatures after only a short period of engine operation and remain hot after you switch the engine off.

Stay clear of the exhaust tailpipe after prolonged driving. Hot exhaust gasses and coming in contact with the tailpipe and/or tailpipe tip can burn you badly.

REGENERATION

Do not park or idle your vehicle over dry leaves, dry grass or other combustible materials. The regeneration process creates very high exhaust gas temperatures and the exhaust will radiate a considerable amount of heat during and after regeneration and after you have switched the engine off. This is a potential fire hazard.

The normal operating temperature of the exhaust system is very high. Never work around or attempt to repair any part of the exhaust system until it has cooled. Use special care when working around the diesel oxidation catalytic converter or diesel particulate filter. The diesel oxidation catalytic converter and the diesel particulate filter heat up to very high temperatures after only a short period of engine operation and remain hot after you switch the engine off.

Stay clear of the exhaust tailpipe during regeneration. Hot exhaust gasses and coming in contact with the tailpipe and/or the tailpipe can burn you badly.

Figure 1

General Assembly Diagram

Item	Description	P/N	Qty.
1	Gasket, Intermediate Pipe	93211	1
2	Intermediate Pipe	53794	1
3	Front Tailpipe	53806	1
4	Rear Tailpipe	53805	1
5	Exhaust band Clamp, 5"	52473	3
6	Tip, Tailpipe	52734/ 52735	1

Note: Tighten all Banks Exhaust band clamps to 50 ft lbs.

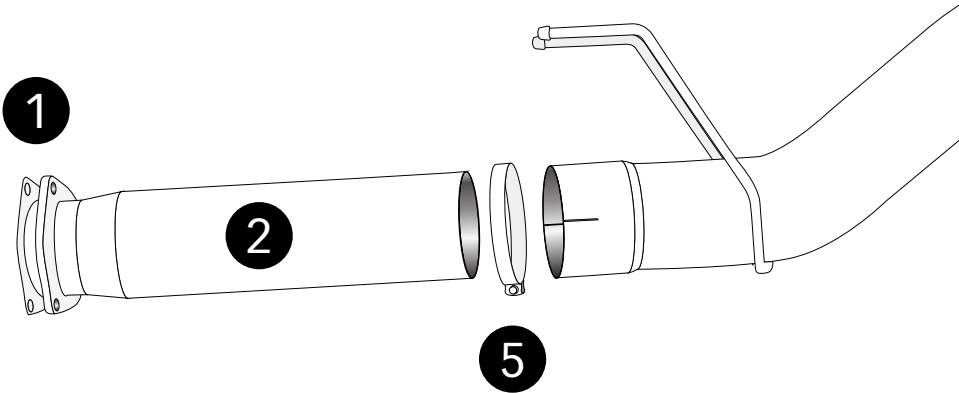

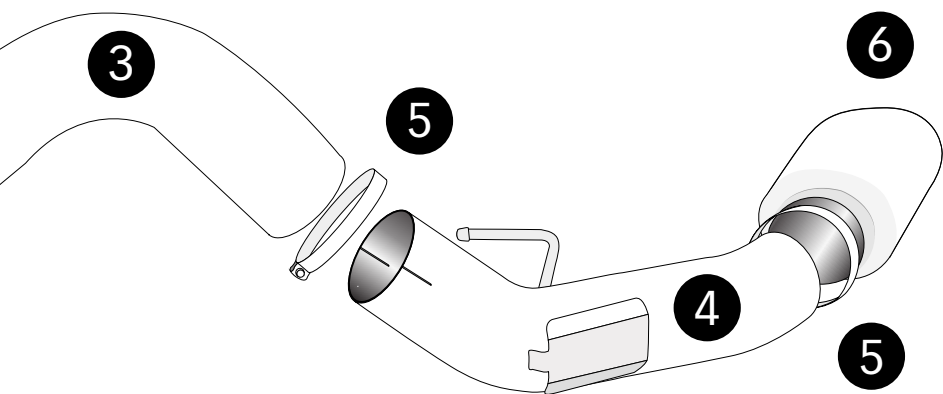

Monster Exhaust System Installation

1. As a precaution, disconnect the ground of the battery (if there is more than one battery, disconnect both).

2. Raise the vehicle and support it with properly weight rated safety stands, ramps or a commercial hoist. Follow the manufacturer's safety precautions. Take care to balance the vehicle to prevent it from slipping or falling. When using ramps, be sure the front wheels are centered squarely on the topsides; place the transmission in park; set the parking brake and place blocks behind the rear wheels.

⚠ CAUTION: DO NOT WORK UNDER ANY VEHICLE SUPPORTED ONLY BY A JACK. SEVERE INJURY MAY RESULT.

3. Remove Factory NOx sensor with a 24 mm wrench and tie safely out of the way to prevent damage. See **Figure 2**.

Figure 2



4. Remove factory tailpipe from the vehicle by disengaging exhaust system hanger pins from the rubber hangers using a large screw-driver or pry bar.

NOTICE: Lubricating the rubber hangers with WD-40 or similar lubricant will ease removal of the hanger pins.

Table 1.

2017+ Ford Power Stroke 6.7L		
	Wheel Base	Cut this length from the Intermediate Pipe. See Figure 3 .
Super Cab/ Short Bed	148"	28.0
Crew Cab/ Short Bed	159.8"	16.2
Super Cab/ Long Bed	164.2"	11.8
Crew Cab/ Long Bed	176"	No Cut

Figure 3

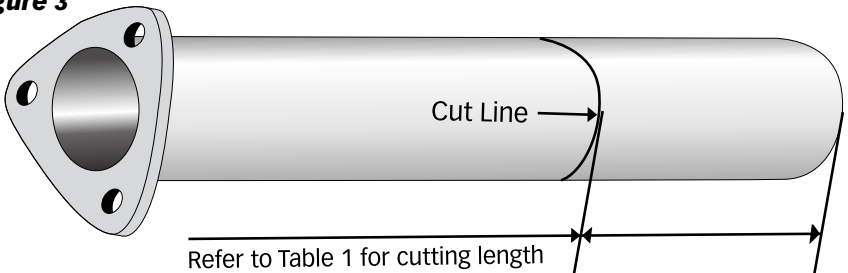

5. Remove the factory exhaust from the vehicle by removing the three (3) nuts from the factory exhaust flange located at the factory exhaust inlet.

6. Locate the supplied intermediate pipe and cut the intermediate pipe based on the following configurations. See **Table 1**. Cut the NON-flanged end of the intermediate pipe. See **Figure 3**.

7. Install the Banks intermediate pipe and 3-bolt gasket onto the headpipe.

8. Slide the supplied 5" exhaust clamp onto the outlet of the Banks flanged intermediate pipe.

9. Route the Front Tailpipe over the rear axle housing. Insert the hanger pins into the factory rubber hanger. Install the Front Tailpipe onto the Banks Intermediate pipe outlet.

10. Install the 5" exhaust clamp onto the inlet of the Rear Tailpipe. Start the Rear Tailpipe hanger pin into the corresponding vehicle rubber hanger. Install the Rear Tailpipe over the outlet of the Front Tailpipe. Slide the 5" clamp into position that best supports the tailpipe assembly. Loosely snug the hanger clamp on the intermediate pipe outlet.

NOTICE: Maintain an adequate air gap clearance of one (1) inch between the exhaust and the shock absorber and between the exhaust and the spare tire.

11. **Figure 4** illustrates the proper location of an exhaust clamp on a tubing joint.

Figure 4

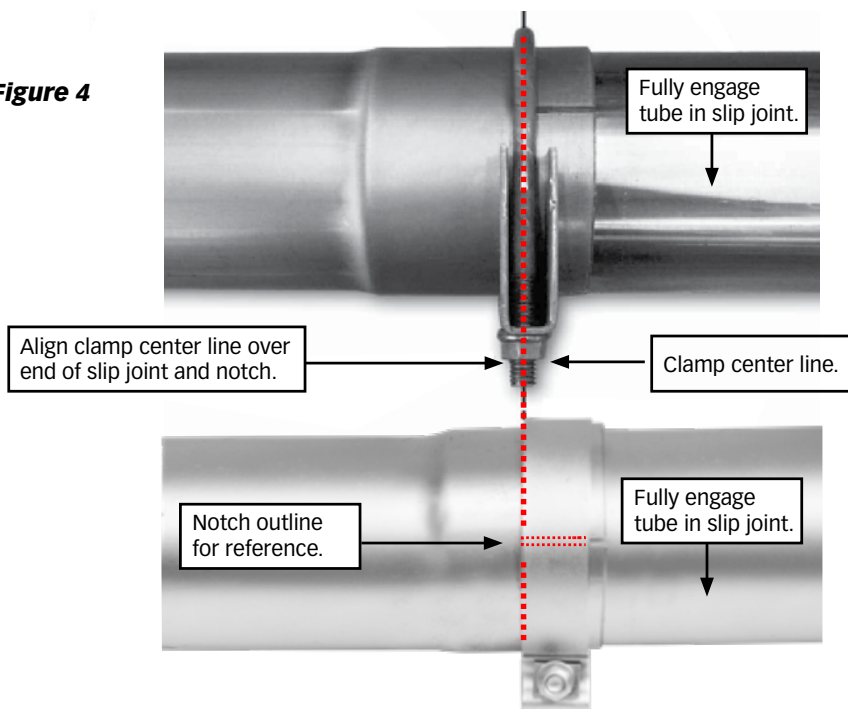
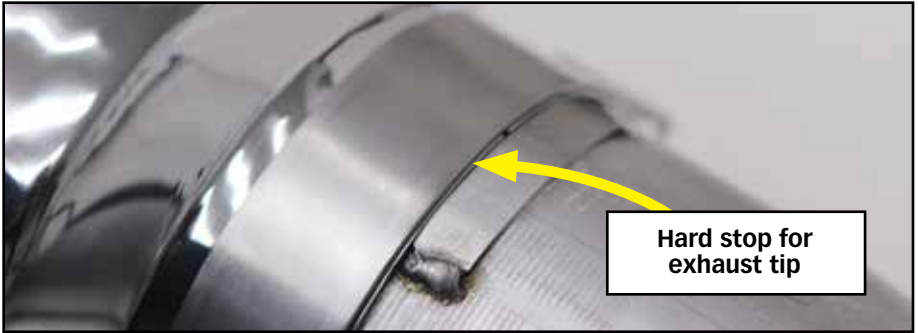

Figure 5



12. Install Banks Monster tailpipe tip with exhaust band clamp on the exhaust. Keep the wrapping on until installation is complete.

Be sure the exhaust tip is fully installed against the welded hard stop on the rear tailpipe (See **Figure 5**).

⚠ CAUTION: Failure to install the exhaust tip completely against the hard stop may result in the exhaust tip falling off while driving.

13. Install Banks Monster tailpipe tip with exhaust band clamp on the exhaust. Keep the wrapping on until installation is complete.

NOTICE: Minimum distance between exhaust tip and body is one (1) inch.

14. With everything positioned properly, begin to tighten the clamps starting with the ones closest to the turbo and working your way back. Tighten all clamps to 50 ft lbs.

15. Re-install factory NOx sensor into Banks exhaust bung. Tighten by hand until snug, then with a wrench: 1/8-1/4 turn.

16. Remove the protective covering from the tailpipe tip.

⚠ CAUTION: THE PROTECTIVE COVERING MAY IGNITE AND BURN IF NOT REMOVED PRIOR TO RUNNING THE ENGINE.

17. Your system includes two “Banks Power” logos designed to complement the Ford badging on your truck. See **Figure 6** to position the logos for a clean factory look.

Figure 6

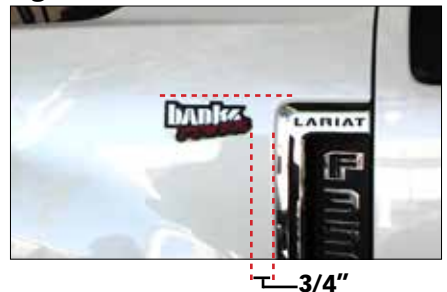

18. Re-connect battery terminals if previously removed. Banks Monster Exhaust installation is now complete.

Gale Banks Engineering
546 Duggan Avenue • Azusa, ca 91702
(626) 969-9600 • Fax (626) 334-1743

Product Information & Sales: (888) 635-4565
Customer Support: (888) 839-5600
Installation Support: (888) 839-2700

bankspower.com