

# INSTALLATION GUIDE

# AMP RESEARCH Power Step™

MADE IN USA

## APPLICATION

Chevrolet Silverado 1500/ GMC Sierra 1500 - All Cabs

\* Modification required to running board assembly. See Item 1 on page 3.

## MODEL YR

2022 - 2023

## PART #

76255-01A

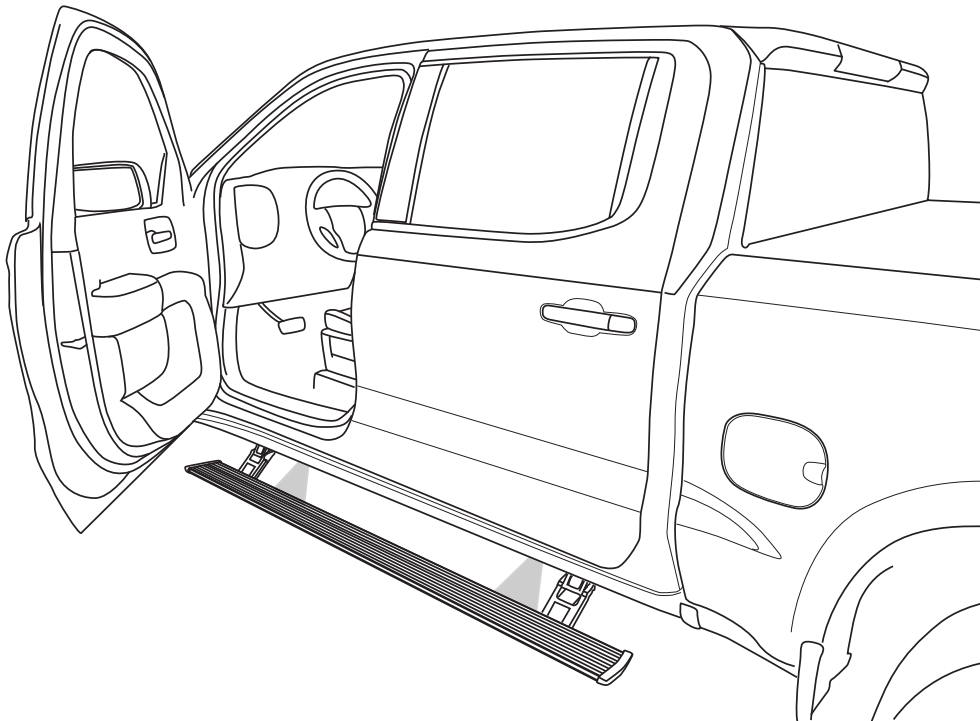

### INSTALLATION TIME

**3-5 Hours**

Professional installation recommended

### SKILL LEVEL



4= Experienced

### TOOLS REQUIRED

- Safety goggles
- Measuring tape
- 1/8", 19/64" Drill bits
- 10 mm socket
- 13 mm socket
- 13 mm ratchet wrench
- Ratchet wrench and extension
- Wire crimpers
- Wire stripper / cutter
- 3/16" hex key wrench (allen wrench)
- 4mm allen wrench
- Electrical tape
- Weather proof caulking (silicone sealer)
- Drill Motor
- Heat Gun

### WARRANTY

**5-Year Limited Warranty**

AMP RESEARCH TECH SUPPORT 1-888-983-2204 (Press 2) Monday - Friday, 7:00 AM - 5:00 PM PST

Invented, engineered and manufactured exclusively by AMP Research in the USA. May be covered by one OR MORE of the following patents: 6,641,158; 6,830,257; 6,834,875; 6,938,909; 7,055,839; 7,380,807; 7,413,204; 7,398,985; 7,584,975; 7,566,064; 7,487,986; 8,157,277; 8,408,571; 9,302,626; 9,561,751; 10,053,017; CA2463717 ©2012 AMP Research. All rights reserved. Printed in USA.

## INSTALLATION GUIDE

### Attaching motor to Linkage assembly

The motors must be attached to the rear Linkages before installation. The Drivers side motor mounts on the opposite side of the linkage as the Passenger side motor does.

#### EXPLODED VIEW

- Motor kit
- Socket cap screws
- Motor Linkage assembly

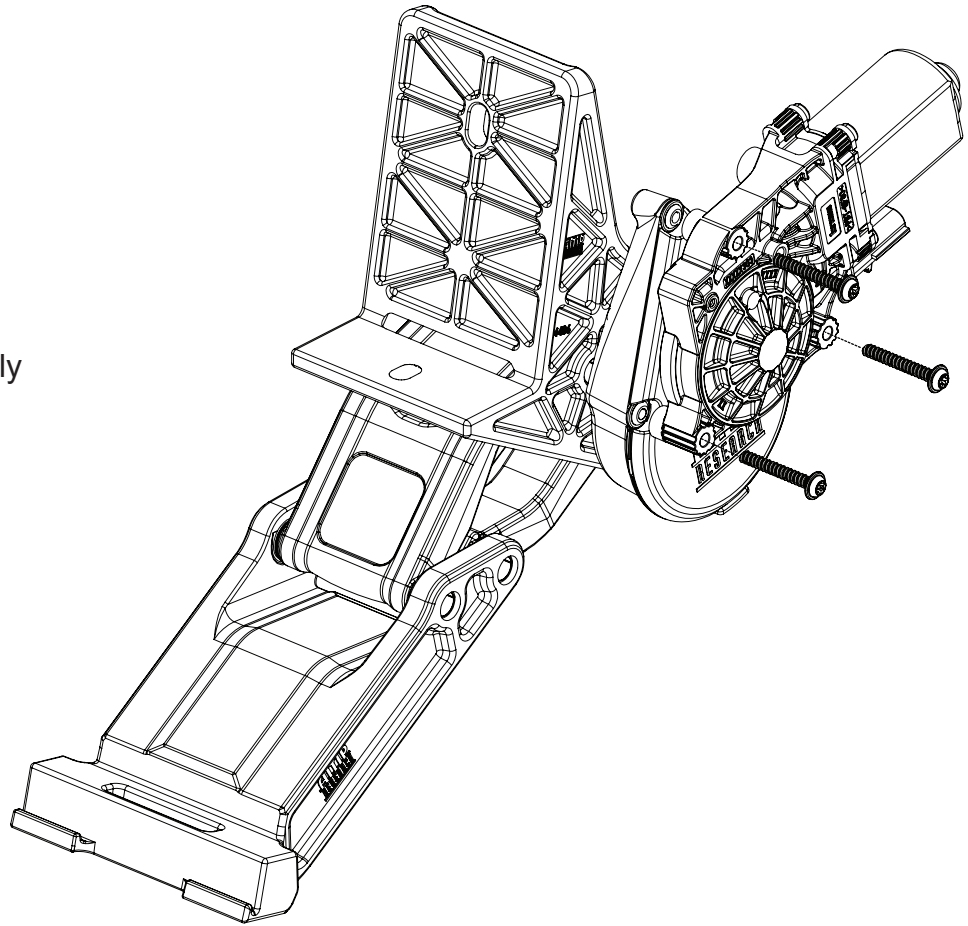

#### CAUTION: HANDLE WITH CARE.

To ensure our customers receive all components with full integrity, we pack the motors separate from their Linkage assemblies. This requires that the installer position and fasten the motor before continuing with the install. Please follow the instructions below and handle the assembly carefully.

CAUTION: Dropping the assembly or any excessive impact MAY cause damage to the motor.

#### Instructions:

1. Position the gear cover in place as shown if not already in place.
2. Seat motor into position on the three mounting bosses. This may require an adjustment of the gear by moving the swing arms.
3. After seating into place, fasten the motor with the three motor mount screws with 4mm Hex Head. Tighten screws to 36 in-lbs (4N-m). **Do not over torque.**

**Note: Some Applications require modification.**

Application	Cut Length
Crew Cab	79" (No Modification Required)
Double Cab	69" (Trim 10")
Single Cab	50" (Trim 29")

PARTS LIST AND HARDWARE IDENTIFICATION

**1** x2  
Running Board assembly

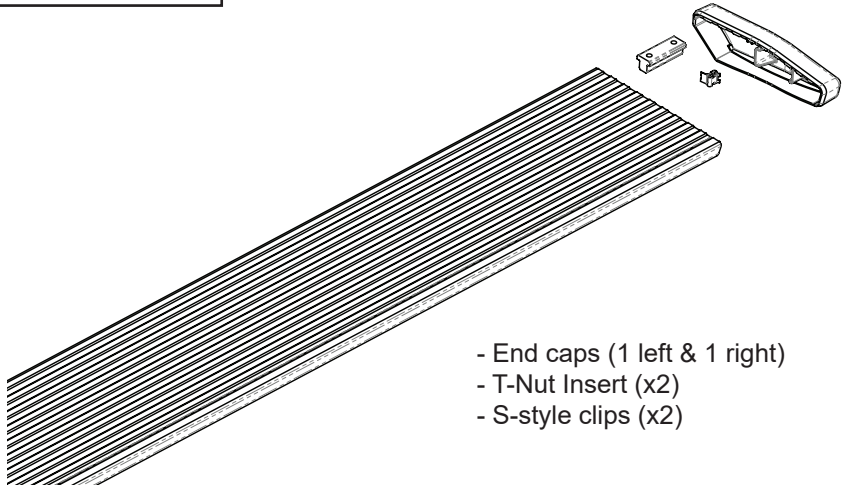

- End caps (1 left & 1 right)
- T-Nut Insert (x2)
- S-style clips (x2)

**2**  
Driver Side Motor Linkage Assembly

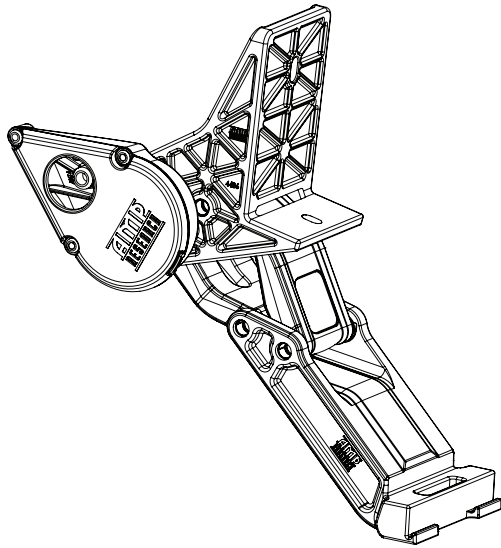

**3**  
Passenger Side Motor Linkage Assembly

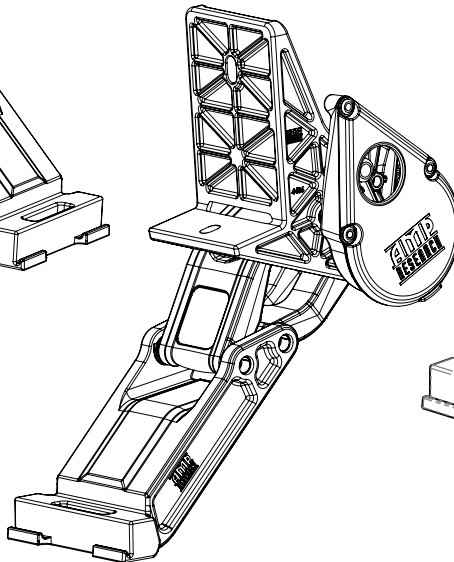

**4** x2  
Front Idler Linkage Assembly

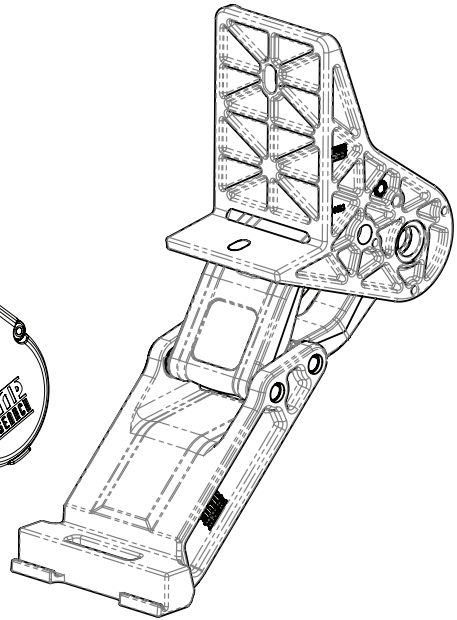

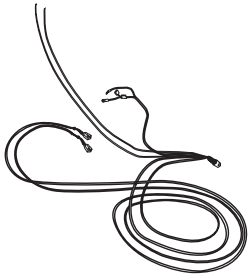

5  
Wire Harness

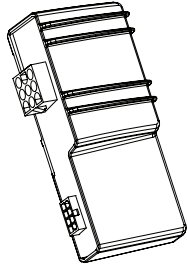

6  
Controller STA

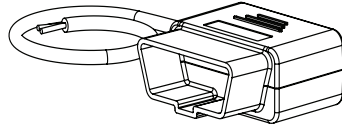

7  
OBD II Plug

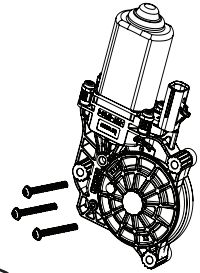

8 x2  
Motor kit

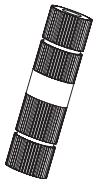

9 x2  
Posi-Tap™  
(Red/Grey)

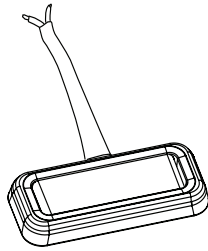

10 x4  
LED Lamp

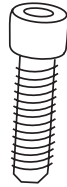

11 x8  
Socket Cap Screw

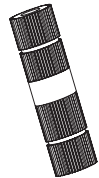

12 x2  
Posi-Lock Connector

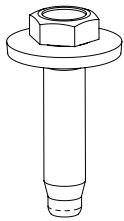

13 x8  
Conical Washer Bolt

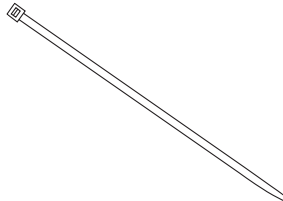

14 x20  
Cable Tie 7"

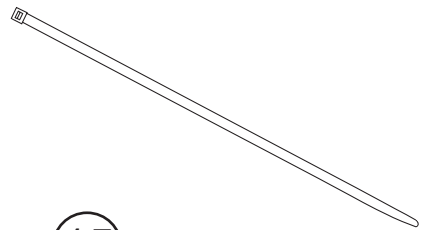

15 x2  
Cable Tie 11"

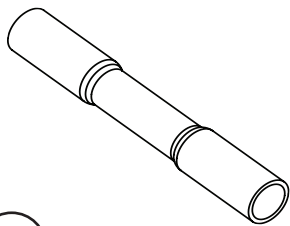

16 x8  
Butt Connector



17 x4  
Grommet

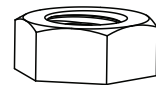

18  
Nut

## Installing Linkages (Driver Side)

### Front Linkage (Idler Linkage)

Install the Idler linkage in the **First mount position at the front of the truck**, for Passenger and Driver sides, using the bolts supplied (13). All plastic or rubber hole plugs need to be removed that are next to the linkage mounts. Also, an extra vertical seam-sealer bead may need to be removed from the front linkage mounting surface.

**Torque fasteners to 16 ft-lbs. (22 N m).**

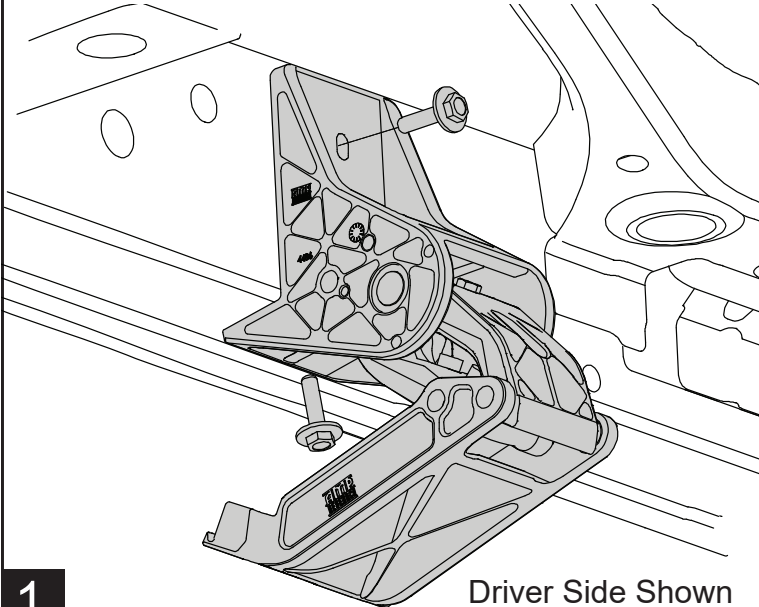

Driver Side Shown

### Rear Linkage (Motor Linkage)

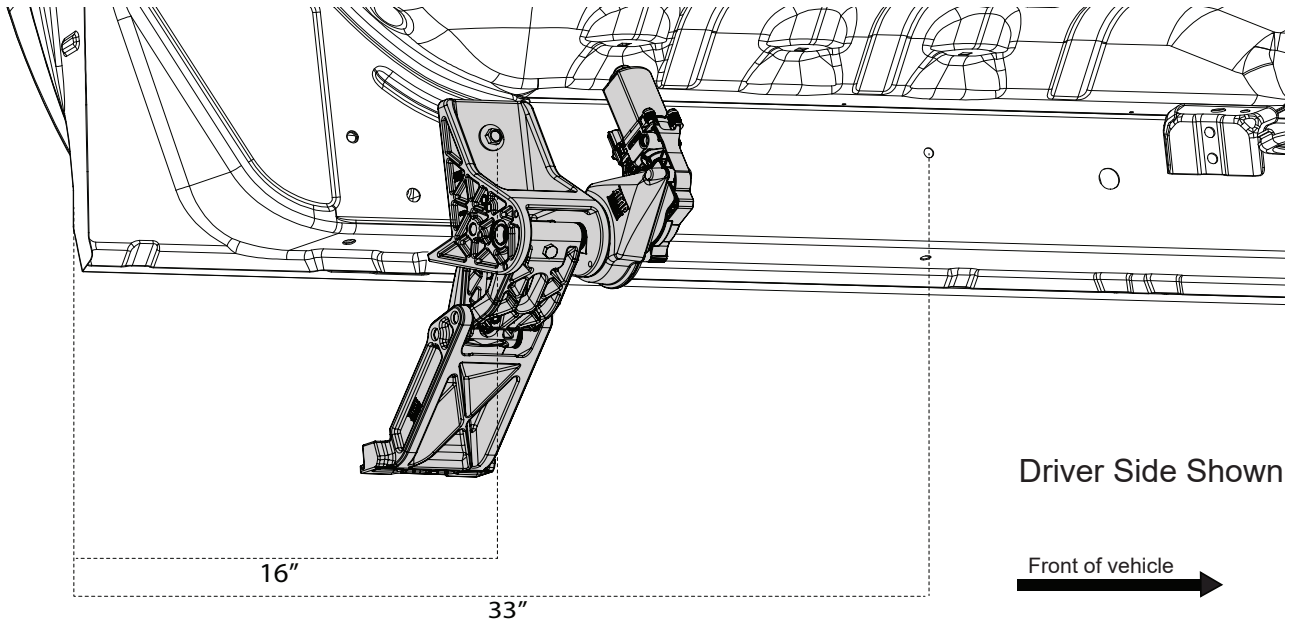

Driver Side Shown

Assemble the motor to the linkage like the picture before installation shown on page 2. **Position the motor so the linkage is in the mid extension position.** This way the lower bolt can still be installed.

Install the motor linkage with provided Conical washer bolts (13) in the second to last set of holes, approximately 16" from rear of cab. Note: On some models these holes are not present. If so use next set of holes forward. Approximately 33" from rear of cab. Keep the linkage held up to the angled surface and the vertical surface. Some structural adhesive remnants may need to be chipped off at the rocker seam. **Torque fasteners to 16 ft-lbs. (22 N m).**

2

## Installing Linkages (Passenger Side)

### Rear Linkage (Motor Linkage)

Install the Motor linkage on the passenger side in the second to last set of holes from the rear. The motor should be facing the front of the vehicle for this side as well. Follow the same step as on the Driver side in the previous step.

**Torque fasteners to 16 ft-lbs. (22 N m).**

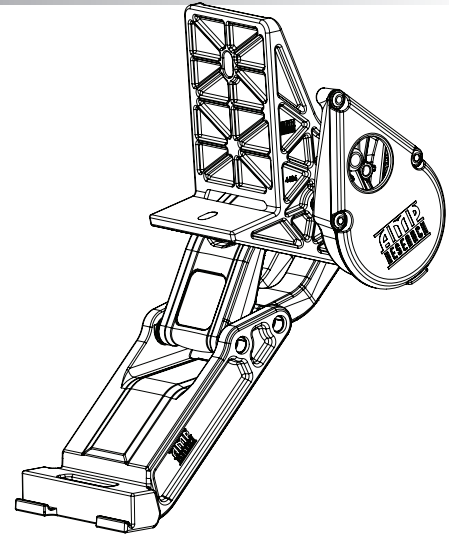

**3**

Slide the front mounting T-nut into position, place the board(1) about 5 to 6 inches from the front edge of the front door. Use fasteners(11) to attach boards, finger tighten only. Align the rear T-nut and bolt it to the rear linkage. Then tighten all 4 fasteners to 10 ft-lbs.

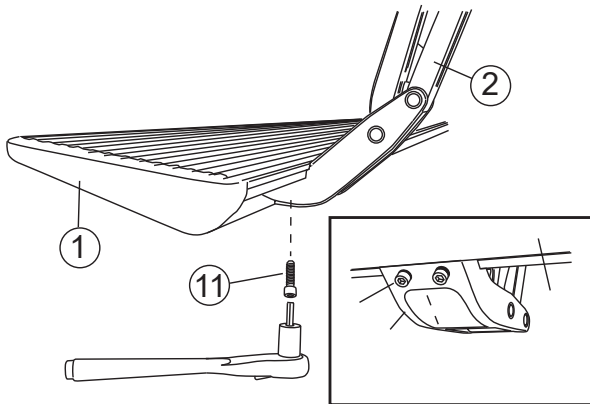

← Front of vehicle  
Driver side shown

**Driver Front Door**

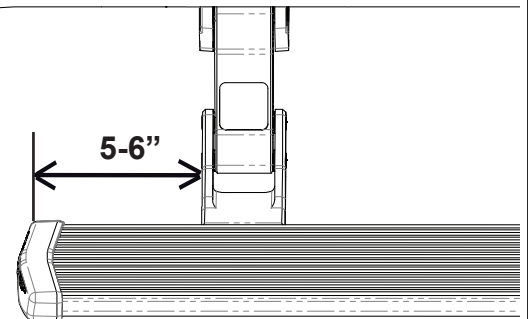

**Torque to 10 ft.lbs.**

**4**

Remove the fuse from the Powerstep wire harness.

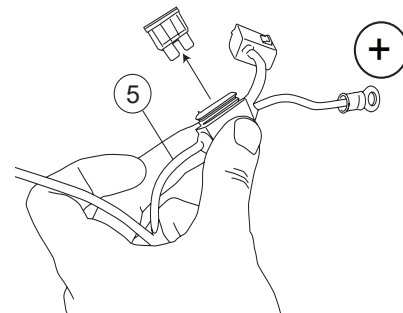

**5**

Plug in the main connectors(5) to the controller(6), then attach the controller to the passenger side wire harness bundle on the outside of the battery. Secure with 11" cable ties(15). Route the long wire harness leg across the truck under the edge of the cowl (zip tied thru the push rivet slots on the bottom), and then down to the outside of the frame away from the exhaust and steering, cable tie(14) it in place. The other leg shall go down immediately away from the exhaust and to the frame area. Cable tie as needed.  
**Note: On dual battery vehicles and Diesel models Passenger side battery is still required.**

Controller

Cowl Edge

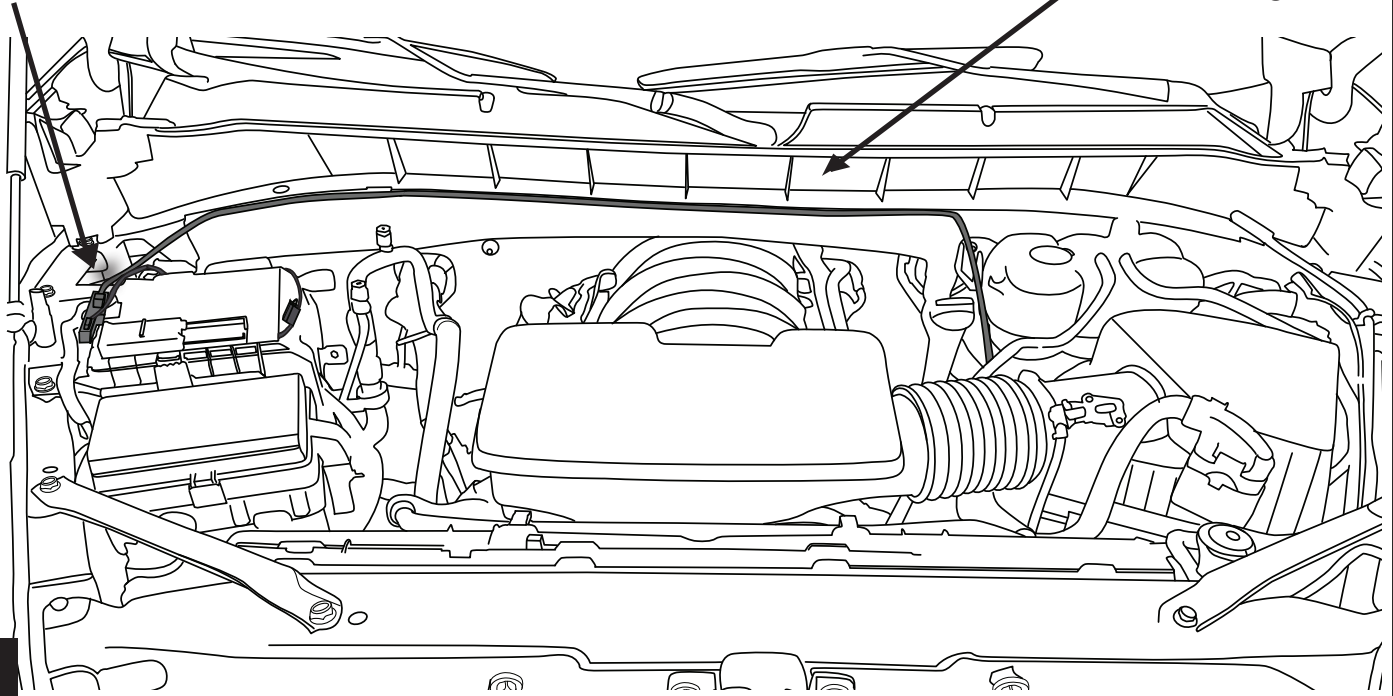

6

**Remove Negative terminal on battery to prevent a CEL when removing Connectors under dash in step 13. A loss of communication code may appear if battery is not disconnected.**

Remove the cover on the battery top box and connect the Black wire to the battery terminal accessory stud. Connect the Red wire to the stud on the positive power battery cable terminal using included Nut (18).

Negative Battery accessory stud ,  
install under factory nut.

Positive terminal accessory  
stud to attach red wire with  
Nut(18).

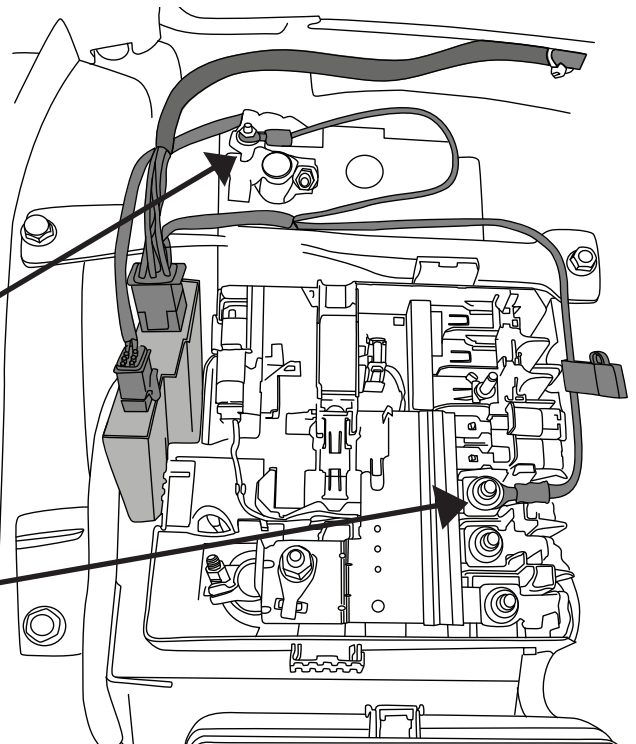

7

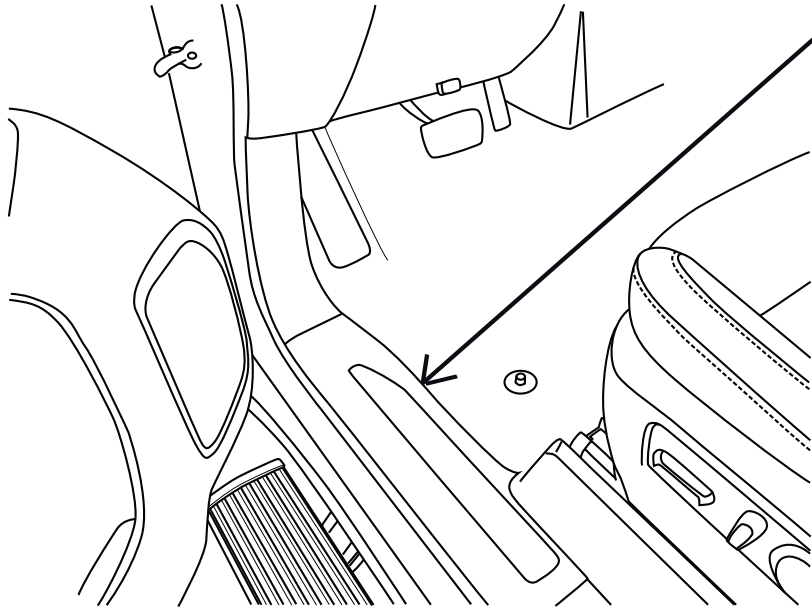

Remove the driver side door sill trim and kick panel carefully. Pull up the carpet, and poke a small screwdriver through the rubber insulation material.

8

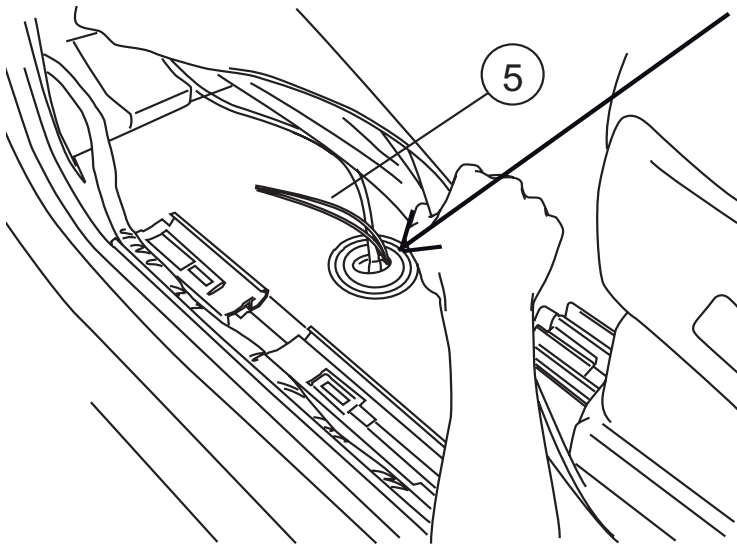

Route the two trigger wires towards the rear of the vehicle above the body mounts, and up through the hole made in the rubber grommet in the previous step. Secure harness with supplied cable ties.

**NOTE:** Seal holes with silicone glue and cover with tape so carpet does not stick to glue.

**On the Driver side, Do Not Ziptie the Wire Harness to the Brake Lines.**

9

In driver side kick panel area, locate bank of 8 plugs. Locate the light grey connector and the light green connector.

a. On dark grey connector, locate the **Light Green/Grey stripe** wire located in pin location 29. Use supplied Posi-tap™ (9) and connect the blue wire from the OBD module.

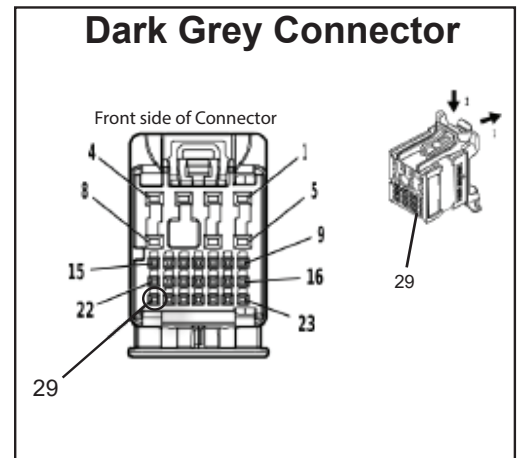
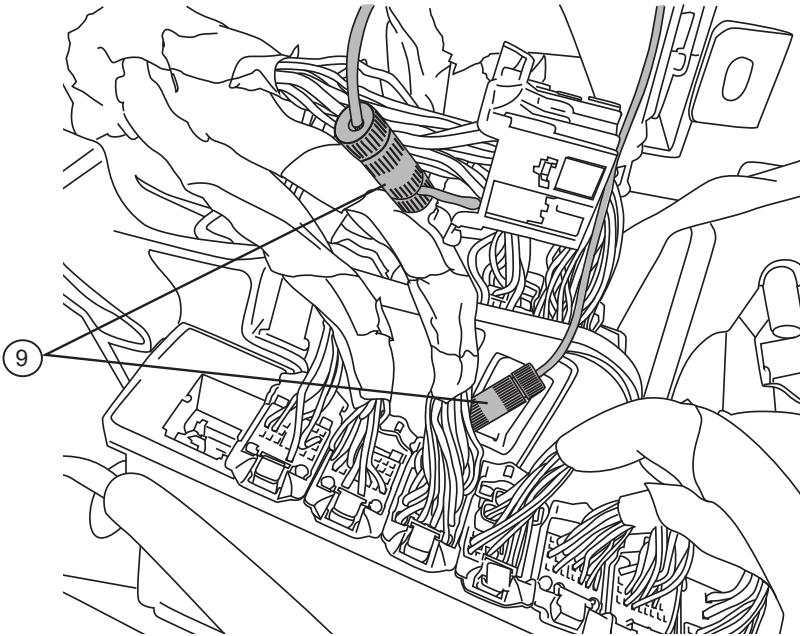

b. On light green connector, locate the **Green/Yellow stripe** wire located in pin location 19. Use supplied Posi-tap™ (9) connector and connect the white wire from the OBD module.

See next step for Posi-lock™ (12) install instructions.

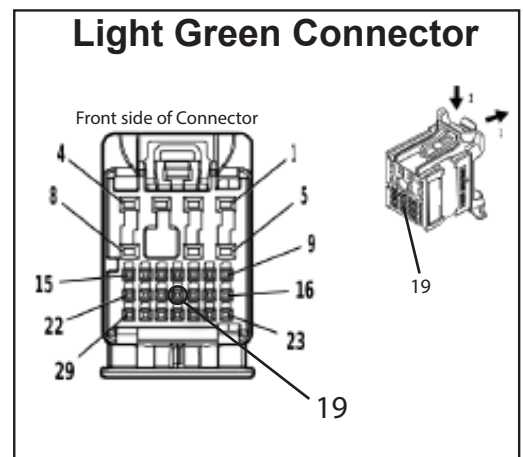
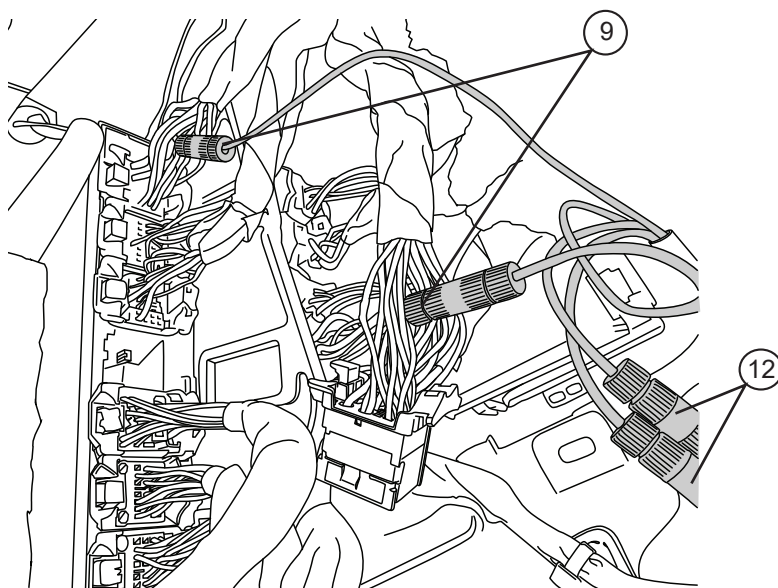

**OBD II install:** Use Supplied Posi Twist connectors to attach the Plug and Play Module to the Harness. Attach matching colors on the harness to the wires on the module. Plug in module (7) to OBD II port on the vehicle. Secure harness with supplied tie wraps. *Note: If the OBD II pass thru harness (76405-01A) was purchased see install sheet supplied in packaging. The pass through harness allows for an open port for other accessories. See below for a brief description.*

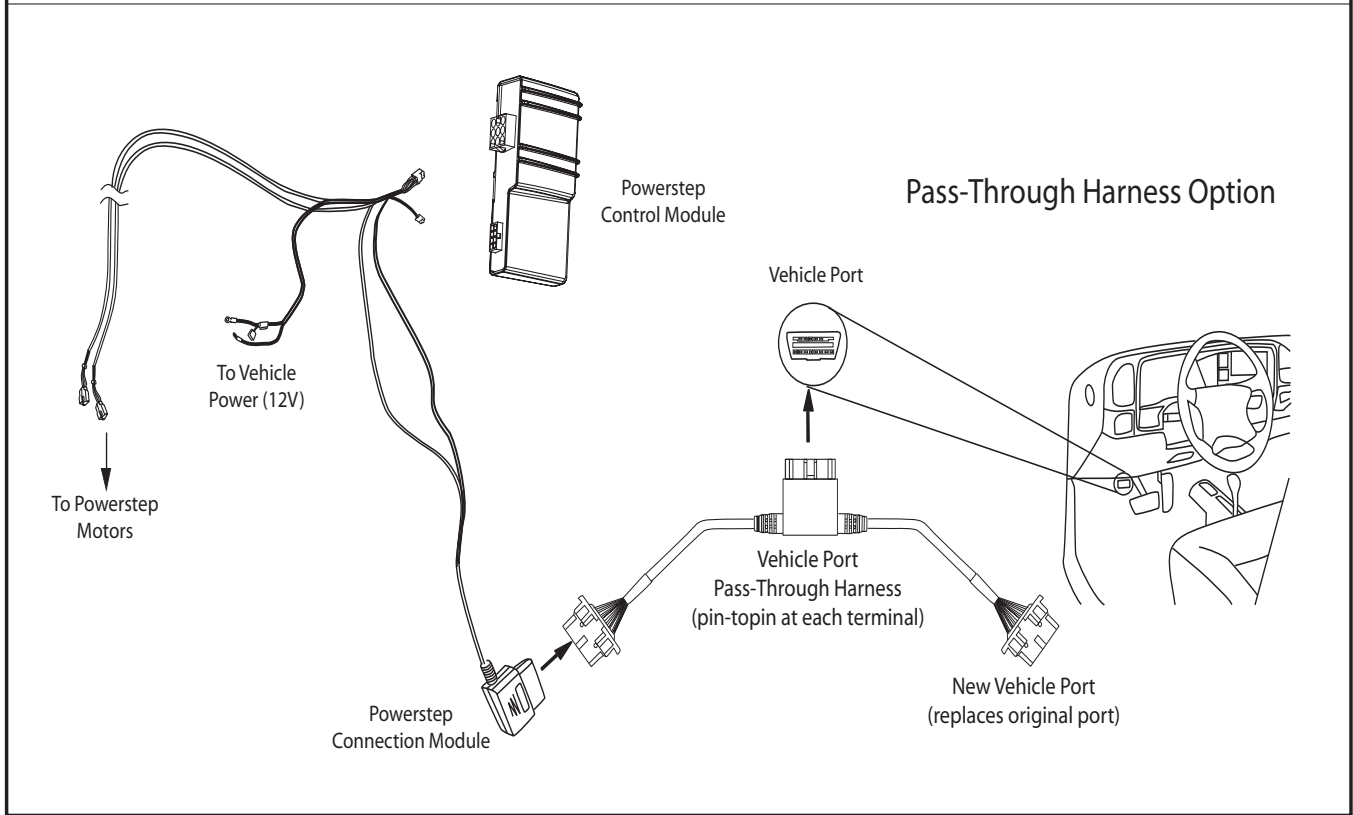
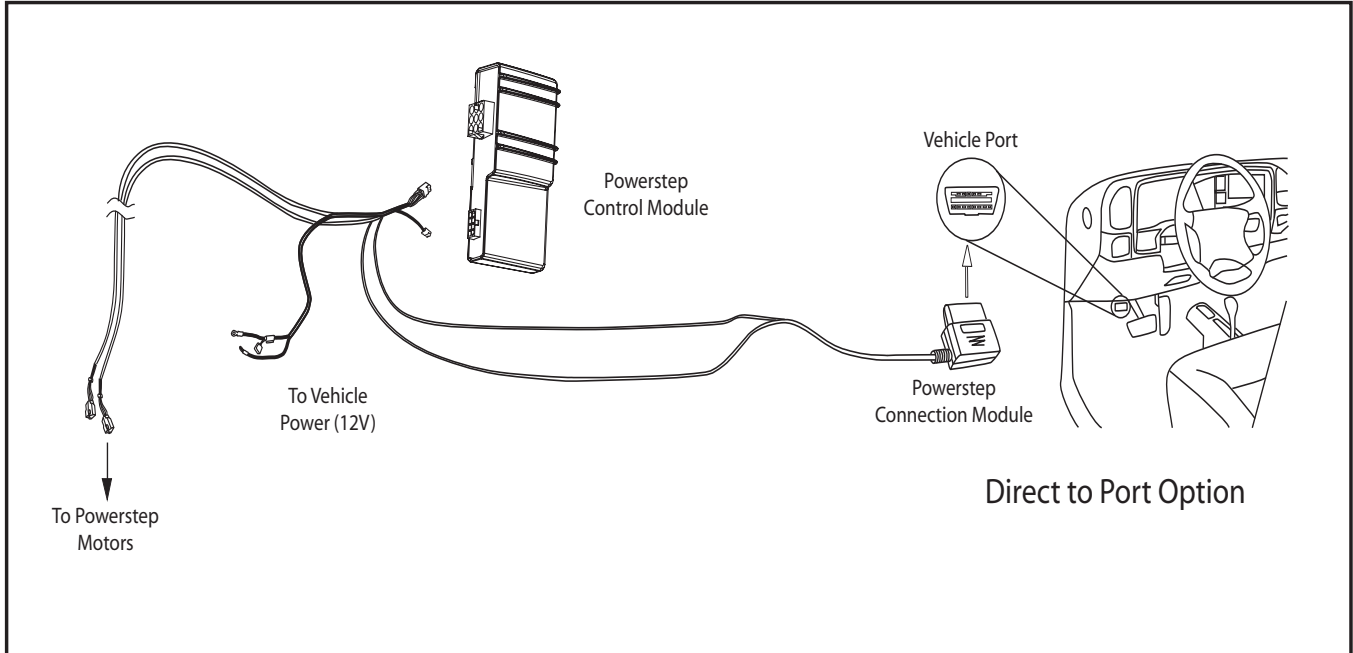

On each side of the vehicle mark the center of each door on the pinch weld and mark for drilling for the light wires in the next step. Make sure there is a clear path to the back of the pinch weld for the wire to enter.

Front of vehicle  
←  
Driver side shown

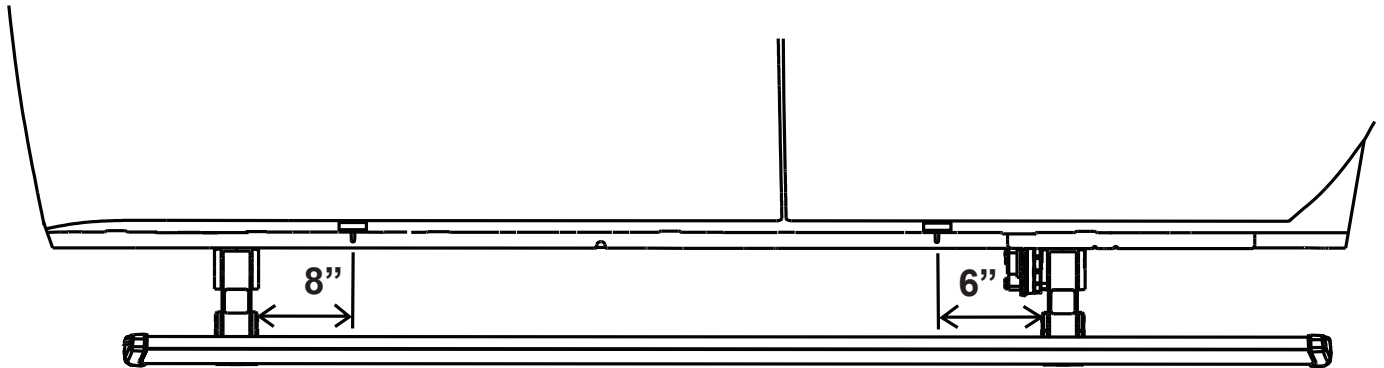

12

Measure down 1/2" from the top of the pinch weld. Center punch and drill a 1/8" pilot hole then drill a 19/64" hole through the pinch weld at marked locations. Deburr all holes. After drilling apply paint to holes to prevent rusting.

**Note: Recommend using a step drill to enlarge holes.**

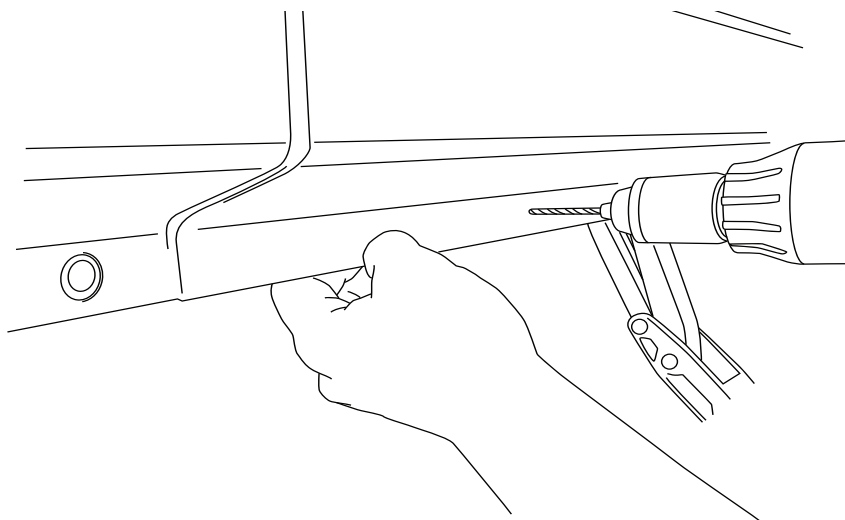

13

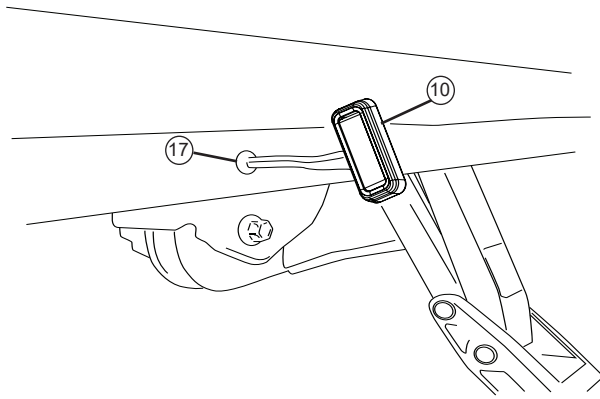

Insert grommet(17) into drilled holes. Insert lamp(10) wires through the grommets. (Silicon lube will help wires slip through grommets.)

14

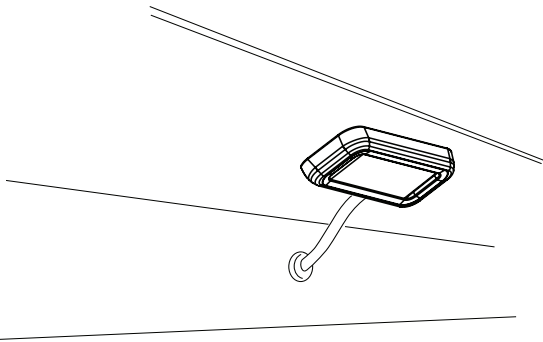

Affix lamp to rocker panel surface. Make sure lamp is affixed to a flat, clean surface.

15

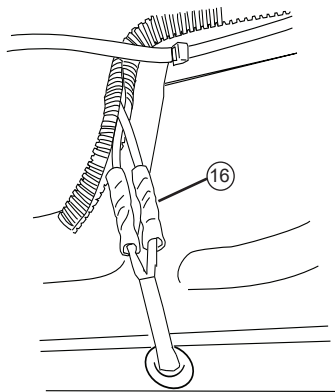

Using supplied butt connectors, connect the lamp wires. Red to Red, Black to Black. Once Crimped use heat gun to shrink tube.

16

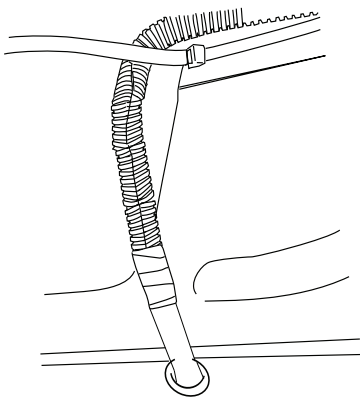

Close and wrap with conduit and electrical tape. Secure all loose wires with cable ties, with lamp wires pulled upward to avoid any wire snagging.

17

Reinstall fuse to wire harness. Check that all doors activate the Power Step and the LED Lights work when doors open and close. Reinstall any remaining trim panels.

**Reinstall fuse.**

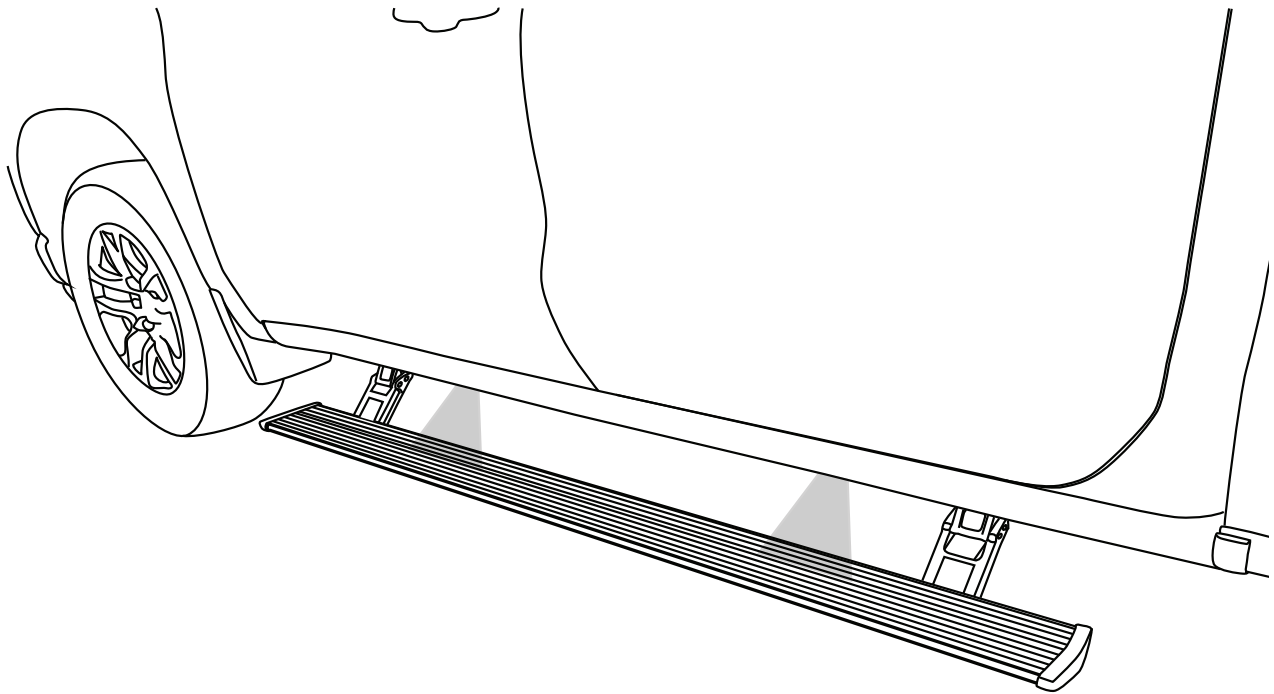
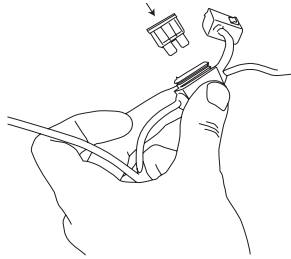

**FINAL SYSTEM CHECK**

Check that all doors activate the PowerStep and the LED lights work when doors open and close.

**NORMAL OPERATION:** When the doors open, PowerStep automatically deploys from under the vehicle. When the doors are closed, PowerStep will automatically return to the stowed/retracted position. **Note that there is a 2-second delay before the PowerStep returns to the stowed/retracted position.**

**CORRECT OPERATION OF LIGHTS:** All four lamps will illuminate upon opening any door of vehicle. Lamps will stay on until restowing of both Power Steps or until 5 minutes has expired with the doors open. When the lights timeout after 5 minutes, they can be reilluminated by closing and opening any door of vehicle.

# **AMP** **RESEARCH** **Power Step**™

**AMERICAN DESIGNED, ENGINEERED AND MANUFACTURED.**

**Thank you for your recent AMP Research Purchase.**

## **REGISTER YOUR PRODUCT TODAY FOR FASTER SERVICE & PRODUCT UPDATES**

Please visit:

**[www.amp-research.com/productregistration](http://www.amp-research.com/productregistration)**  
or scan the QR Code



### **Product Registration Benefits:**

- Ensure we have your purchase receipt and product info in our system which is required for warranty
- Faster and easier access to customer service and tech support in the unlikely event you need warranty or product support
- Registration helps us keep you up to date on product information and offers

To view other Amp Research products that may be offered for your vehicle.

**Please visit: [www.amp-research.com](http://www.amp-research.com)**

Rev 01.05.21

**POWER-DEPLOYABLE RUNNING BOARDS OPERATION:** AMP Research PowerStep running boards automatically move when the doors are opened to assist entering and exiting the vehicle.

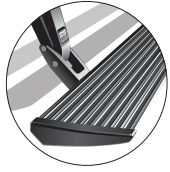

**Automatic power deploy:**

The running boards will extend down and out when the doors are opened.

**Automatic power stow:**

The running boards will return to the stowed position when the doors are closed. There will be a 2-second delay before the running boards move to the stowed position.

**Automatic stop:**

If an object is in the way of the moving running board, the running board will automatically stop. To reset, clear any obstruction, then simply open and close the door to resume normal operation.



**Manually set in the deployed (OUT) position for access to the roof:**

The running boards can be manually set in the deployed position by firmly holding the step down with your foot while at the same time closing the door. To resume normal operation, open and close the door.

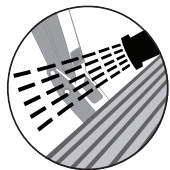

**Maintenance:** In adverse conditions, debris such as mud, dirt, and salt may become trapped in the running board mechanism, possibly leading to unwanted noise. If this occurs, manually set the running boards to the deployed position and flush the front and rear hinge arms with a high-pressure car wash wand. Avoid spraying the motors directly. After washing, apply silicone spray lubricant to the hinge pivot pins. Do not apply silicone, wax or protectants like Armor All® to the running board stepping surface.

**Caution!** Keep hands away when the running board is in motion.

## 5-YEAR LIMITED WARRANTY

AMP RESEARCH warrants this product to be free from defects in material and workmanship for FIVE (5) YEARS FROM DATE OF PURCHASE, provided there has been normal use and proper maintenance. This warranty applies to the original purchaser only. All remedies under this warranty are limited to the repair replacement of the product itself, or the repair or replacement of any component part thereof, found by the factory to be defective within the time period specified. The decision to repair or replace is wholly within the discretion of the manufacturer.

This warranty specifically excludes labor. If you have a warranty claim, first you must call our factory at the number below for instructions. You must retain proof of purchase and submit a copy with any items returned for warranty work. Upon completion of warranty work, if any, we will return the repaired or replaced item or items to you freight prepaid. Damage to our products caused by accidents, fire, vandalism, negligence, misinstallation, misuse, Acts of God, or by defective parts not manufactured by us, is not covered under this warranty.

ANY IMPLIED WARRANTIES OF MERCHANTABILITY AND/OR FITNESS FOR A PARTICULAR PURPOSE CREATED HEREBY ARE LIMITED IN DURATION TO THE SAME DURATION AND SCOPE AS THE EXPRESS WRITTEN WARRANTY. OUR COMPANY SHALL NOT BE LIABLE FOR ANY INCIDENTAL OR CONSEQUENTIAL DAMAGE.

Some states do not allow limitations on how long an implied warranty lasts, or the exclusion or limitation of incidental or consequential damages, so the above limitations or exclusions may not apply to you. This warranty gives you specific legal rights, and you may also have other rights that vary from state to state.

FOR WARRANTY ISSUES WITH THIS PRODUCT PLEASE CALL AMP RESEARCH TECH SUPPORT 1-888-983-2204

## WARNING

Be sure to read and precisely follow the provided instructions when installing this product. Failure to do so could place the vehicle occupants in a potentially dangerous situation. After installing or reinstalling, re-check to insure that the product is properly installed.



The material that your product is made from can be recycled. Please also consider recycling the packaging that your product came in.

