

# Hard Tri-Fold Cover Special Clamp Instructions



## Special Instructions for 2015-ON Chevy Colorado/GMC Canyon Shims and Clamps

**INSTALLER:** These instructions must be given to the consumer.

**CONSUMER:** Save this insert for future reference.

**READ AND FOLLOW THESE SPECIAL INSTRUCTIONS ALONG WITH THE STANDARD INSTRUCTIONS CAREFULLY BEFORE INSTALLING OR USING THIS COVER.**

Actual parts may vary from those shown in this booklet.

# 1: INSTALLING SHIMS AND SHORT CLAMPS

A. Clean area where shims are to be placed. Peel paper back and adhere shims to box rail between box rail protector and box rail at clamp locations specified in Step 1 of owner's manual. Shim should be flush with bottom of the box rail protector.

**NOTE: For best adhesion, air and surface temperature should be above 60° F. If shim causes rail protector to bulge, reinstall shim lower.**

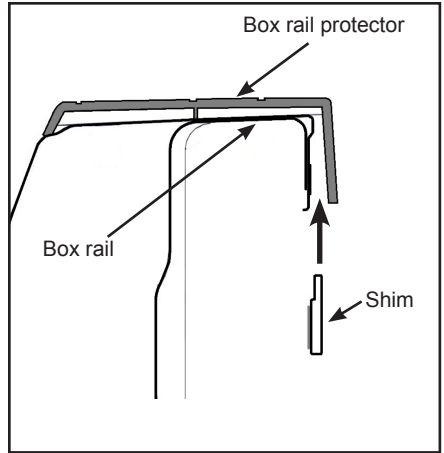

B. Install clamp at each shim location. Orientate clamp halves so long legs are towards bottom.

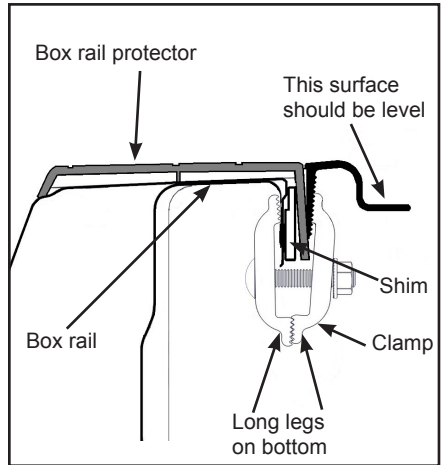

## 2: INSTALLING LONG CLAMPS

A. At rear of box under large hole in line with stake pocket, clean area and apply self adhesive protective strip.

**NOTE: If box has drop-in liner, cut liner to clear room for clamp.**



B. At top of rear stake pocket, lower back half of long clamp with fish wire and carriage bolt down into pocket.

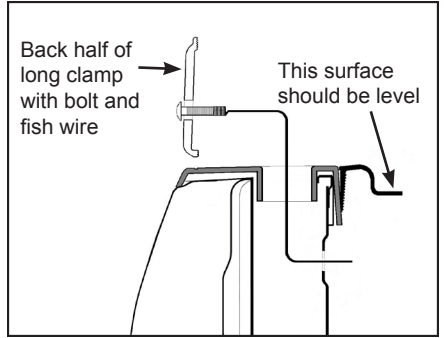

C. Using fish wire align and pull bolt through hole on inside wall of box and hold there for next step.



D. Place other half of clamp over bolt and turn nut finger tight.



## 2: INSTALLING LONG CLAMPS (Continued)

E. Adjust side rail height to clear tailgate as specified in owner's manual and hold. Push clamp up under side rail and tighten bolt. Torque this bolt to 20 ft. lbs. Repeat for opposite side.

**IMPORTANT: Make sure clamps are lined up properly prior to tightening bolt. (See diagrams below)**

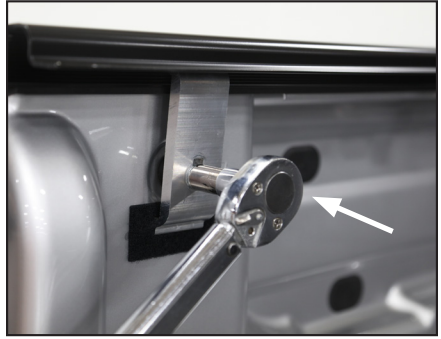

**ALTERNATE LOCATION OF LONG CLAMP - only if stake pocket is not available, use shim at this location.** Even if stake pocket is utilized with an accessory, remove it and check for space. Usually the long clamp will install down in the pocket and still allow the accessory to be remounted.

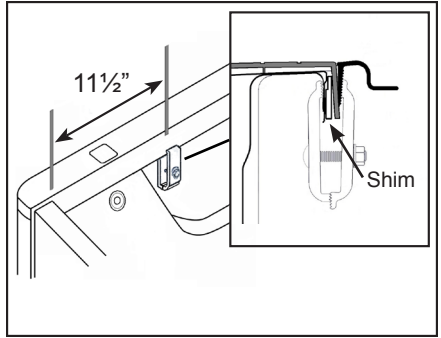

### Tall Clamps Inside Rear Stake Pocket

