

Installation Manual



AIR SUSPENSION KIT

Ford F-250 F-350 & F-450 Super Duty (2WD/4WD)*

Will fit models equipped with or without 5th wheel hitch

Eliminate your vehicle's sag, sway and bottoming out while providing added support for an overall smooth and safe ride with this extreme duty air suspension kit. Rated for up to 7500 lbs of load-leveling capacity⁺, this kit is ideally suited for those towing/hauling big loads on a regular basis.

* See application guide for proper fitment.

+ Applications vary. Never exceed manufacturer's recommended Gross Vehicle Weight Rating

Thank you and congratulations on the purchase of an Air Suspension kit. Please read the entire manual prior to starting the installation to ensure you can complete it once started.

IMPORTANT

This air suspension kit will not increase the GVWR (*Gross Vehicle Weight Rating*), as the GVWR is determined by the vehicle manufacturer. **Do not exceed the maximum capacity listed by the vehicle manufacturer.**

For safe and proper operation of the vehicle, never exceed a maximum of 100PSI in the air springs. Staying under the pressure limit will ensure maximum air spring life. **Failure in doing so may result in damage to your vehicle and/or a void warranty.**

SAFETY WARNINGS!

! Please read and abide the instructions found in this manual, paying close attention to the helpful, cautionary or dangerous warning icons highlighting important safety recommendations and maintenance suggestions throughout this manual.

+ **HELPFUL INSTALL TIP**
Additional information that could potentially make the job a little easier.

! **PLEASE USE CAUTION**
Unsafe practices could result in damage to you or your vehicle, or others.

! **DANGER WARNING**
Hazards which could result in severe personal injury or death.

! Serious personal injury or death may result from an air spring failure or accident due to improper installation or air spring pressure operation or maintenance.

! Inflating an unsecured air spring is dangerous. If it bursts, it could be hurled into the air with explosive force resulting in serious personal injury or death. Never inflate an air spring unless it is secured to the vehicle.

! Removing and replacing air springs can be dangerous. This is only a job for a qualified service professional. Never perform air spring service procedures without proper training, tools, and equipment.

BEFORE STARTING THE INSTALLATION

- Ensure the application information is correct for the make, model and year of the vehicle you are installing the kit on.
 - Some vehicles are equipped with a rear wheel brake proportioning valve. Check with the manufacturer before installing the air spring kit, as it may affect braking performance.
 - It is recommended to use a good quality anti-seize on all fasteners. This will reduce the chance of corrosion on the fasteners and will help facilitate removal, if required at a later date.
- !** **PLEASE NOTE:** This kit contains push-to-connect fittings; using scissors or wire cutters to cut the nylon air line will distort the line and cause the connection to leak. The air line must be cut off squarely with the hose cutter provided in this kit, or a sharp utility knife. **Failure to do so may void the warranty.**

! **WARNING:** This product can expose you to the chemical Hexavalent Chromate, which is known to the State of California to cause cancer and birth defects or other reproductive harm. **For more information go to www.P65Warnings.ca.gov**

KIT CONTENTS

Please confirm the items below are provided in your kit before starting the installation. Reference the kit explosion diagrams on the following pages for part assembly.

XTREME DUTY KITS		QTY	PART #
A*	Double Convoluted Spring	2	HP10438

XTREME DUTY JOUNCE BUMPER KITS		QTY	PART #
A*	Double Convoluted Spring w/ Jounce Bumper	2	HP10438J

KIT CONTENTS		QTY	PART #
B	Roll Plate	4	HP10069
C	Lower Air Spring Bracket	2	HP1673
D	Lower Axle Bracket	2	HP1674
E	Upper Driver Bracket	1	HP1679
F	Upper Passenger Bracket	1	HP1682
G	L-Bracket	1	HP1379
H	Spacer	2	HP1364
I	Axle Strap	2	HP1678
J	U-Bolt, 3/8" – 16 x 7" x 5.5" Square	2	HP1486
K	Bolt, 1/4" – 20 x 1" Hex Head	1	P34637
L	Bolt, 5/16" – 24 x 1" Hex Head	1	C10465
M	Bolt, 3/8" – 24 x 7/8" Hex Head	4	HP1002
N	Bolt, 3/8" – 24 x 3/4" Countersunk	4	HP1008
O	Bolt, 3/8" – 16 x 1.5" Hex Head	8	HP1646
P	Bolt, 3/8" – 16 x 2" Carriage	2	HP1447
Q	Bolt, 3/8" – 16 x 6" Carriage	4	HP1685
R	Bolt, 1/2" – 13 x 1.25" Hex Head	2	HP1371
S	Bolt, 1/2" – 13 x 3" Hex Head	2	HP1324
T	Washer, 1/4" Flat	2	P02190
U	Washer, 5/16" Flat	2	C11944
V	Washer, 3/8" Flat	28	C653
W	Washer, 3/8" Split Lock	4	C18007
X	Washer, 1/2" x 1.375" OD Flat	3	HP1368
Y	Washer, 1/2" x 2" OD Thin Flat	2	HP1010
Z	Washer, 1/2" x 2" OD Thick Flat	2	HP1369
AA	Washer, 3/4" Flat	1	HP1446
BB	Nut, 1/4" Nylon Lock	1	HP1072
CC	Nut, 5/16" Nylon Lock	1	C10450
DD	Nut, 3/8" Nylon Lock	16	HP1000
EE	Nut, 3/8" Serrated Flange	2	HP1338
FF	Nut, 1/2" Serrated Flange	2	HP1370
GG	Heat Shield	1	HP0012
HH	Worm Gear Ring Clamp	2	HP1377
II	Fitting, Straight Brass	2	HP1385

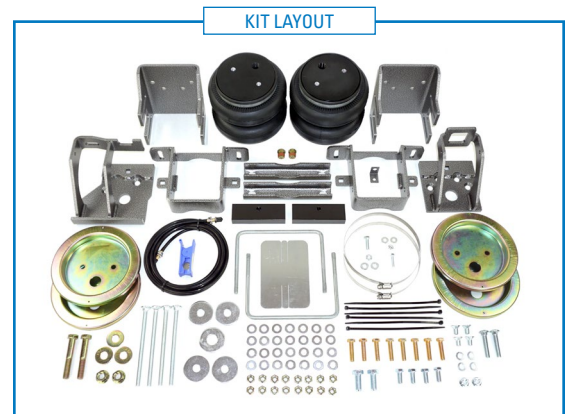
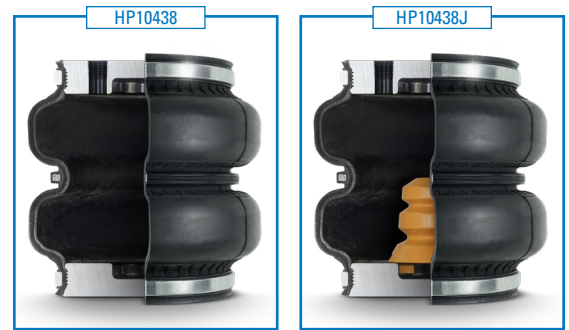

REQUIRED TOOLS

- Hoist or Floor Jack
- Safety Stands
- Safety Glasses
- Torque Wrench
- Standard Combination Wrenches
- 7/32" Hex Allen Wrench
- Ratchet
- Metric & Standard Sockets
- Hose Cutter (included) or Sharp Utility Knife
- Pipe Thread Sealant
- Spray Bottle with Dish Soap/Water
- Air Compressor/Compressed Air Source (to test/fill air springs)

KIT EXPLOSION DIAGRAM

DRIVER SIDE ASSEMBLY SHOWN (Passenger side on following page)

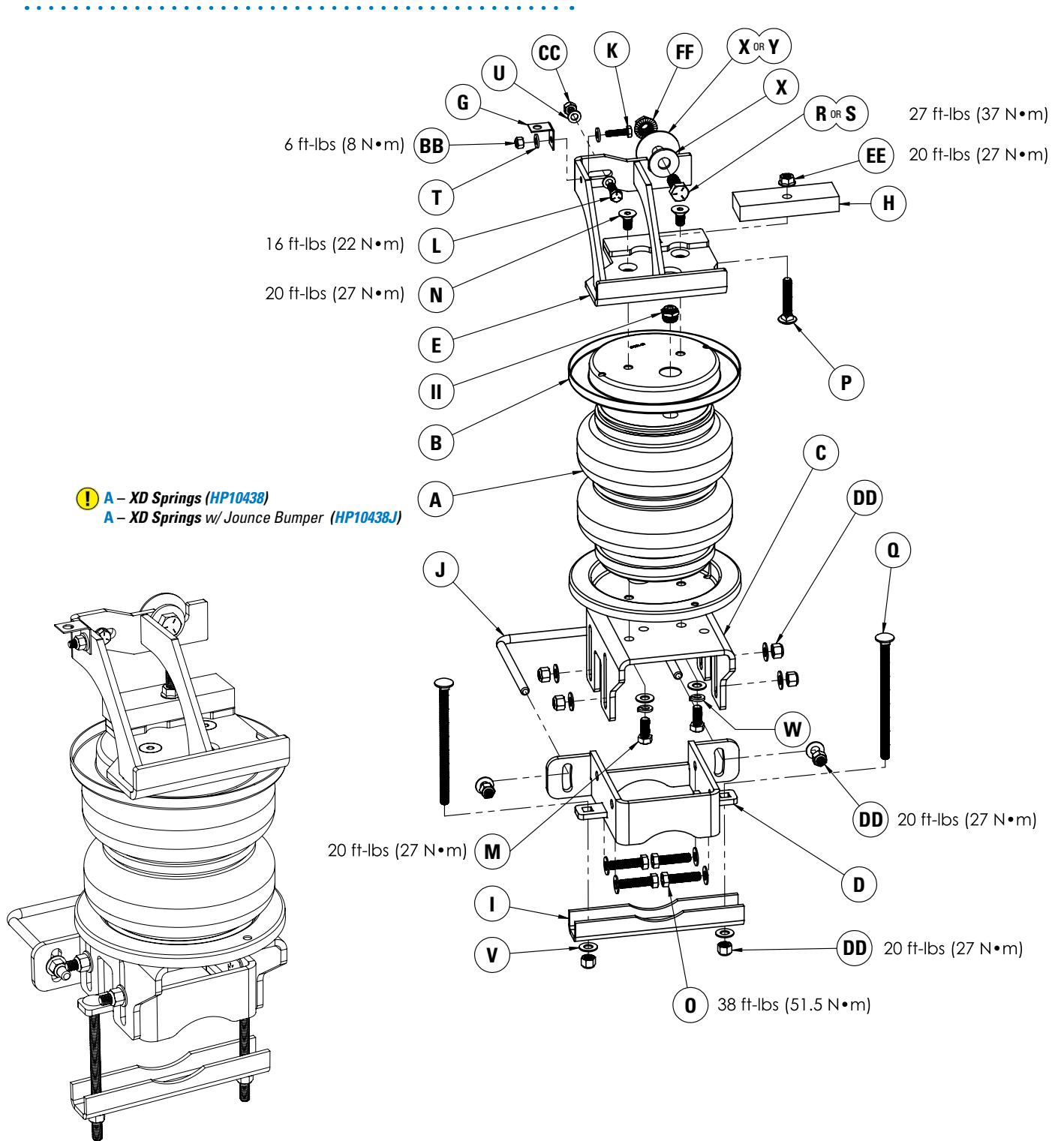

INSTALLATION INSTRUCTIONS

1 MEASURE STOCK RIDE HEIGHT & CLEARANCE

Park the vehicle on a level surface and remove any unnecessary weight from the vehicle to attain a "Normal Ride Height".

Using a measuring tape, measure the distance between the center of the wheel hub and the bottom of the fender well (see Figure 1A for reference) this will give you your stock Normal Ride Height.

Note the ride height for all four tires.

Check the clearance between the outside of the frame and the inside of the rear tires (as shown in red in Figure 1B), a minimum of 5" is required for adequate air spring clearance.

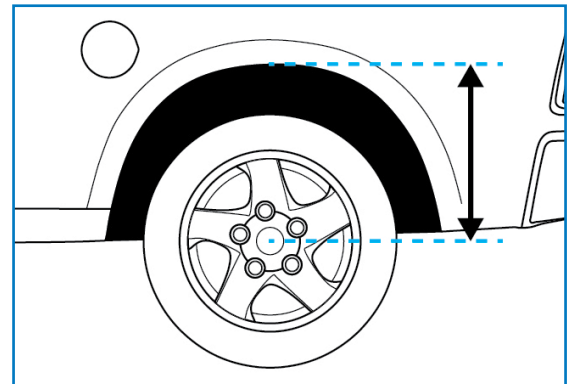

1A

2 REMOVE REAR WHEELS

+ PLEASE NOTE: This step is optional for this installation but will make the install easier to complete.

Place wheel chocks in front of and behind both front wheels.

Raise the rear of the truck high enough to remove both wheels and attain a comfortable working height.

Place two jack stands under rear axle (as shown in Figure 1B).

Lower the vehicle until the axle is supported by the jack stands.

Remove rear wheels.

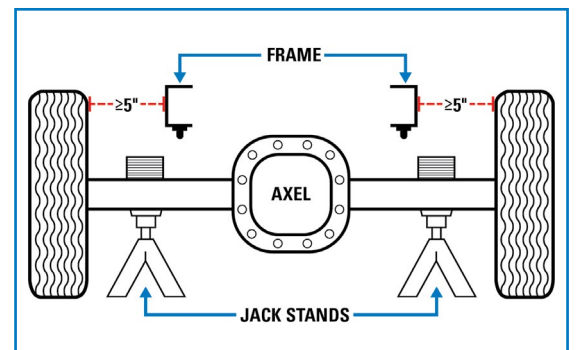

1B

3 REMOVE JOUNCE BUMPER, EMISSION LINE CLIP & AFTERMARKET FIFTH WHEEL HARDWARE (IF EQUIPPED)

Remove the flange nut securing the jounce bumper to the frame rail using a 13mm wrench or socket. (See Figure 3A).

+ Discard the nuts as they will not be reused in this installation.

Step continues on following page...

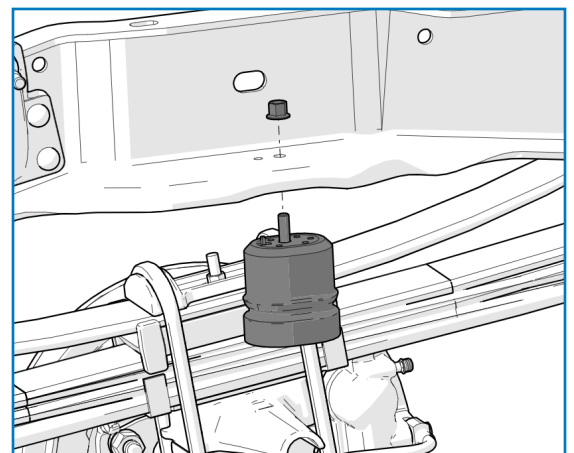

3A

If the truck is equipped with an aftermarket fifth wheel hitch that uses the slotted hole in the frame above the jounce bumper mounting location (shown in Figure 3B), remove the hardware bolting the hitch plate to the frame. Keep all hardware for reinstallation with kit upper brackets.

If the truck is equipped with an emission line running inside the frame, it must be relocated to allow fitment of the upper driver bracket. On the driver's side, check if a line is clipped to the hole above the jounce bumper (shown in Figure 3C).

If equipped, carefully remove the harness clip from the frame hole and gently pull the lines upwards.

4 INSTALL AIR FITTINGS

Install the straight brass fitting into each air spring (shown in Figure 4).

Thread the fitting finger tight plus an additional 1.5 turns.

 *The use of thread sealant or Teflon tape is recommended.*

Set a roll plate (as shown) on the top surface of the air spring after the fitting is tightened.

5 INSTALL SPACERS ON UPPER BRACKETS

Install a spacer on each upper bracket (as shown with an arrow in Figure 5A) with a 3/8" – 16 x 2" Carriage Bolt.

Ensure the long side of the spacer (indicated with an arrow in Figure 5B) faces away from the air spring mounting holes.

6 ATTACH UPPER PASSENGER BRACKET TO AIR SPRING

Assemble the passenger side spring assembly (as shown in Figure 6 on the following page) by placing the upper passenger bracket with spacer on the air spring and roll plate.

Align the indicated bracket holes with the holes in the roll plate and air spring and secure using two 3/8" – 24 x 3/4" Countersunk bolts.

Torque bolts to 27 N•m (20 ft-lbs).

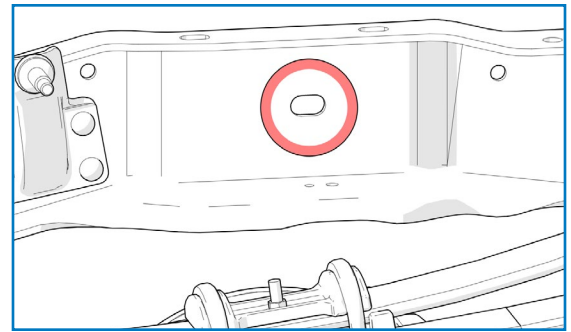

3B

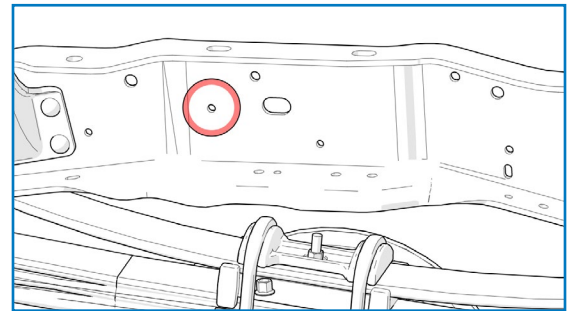

3C

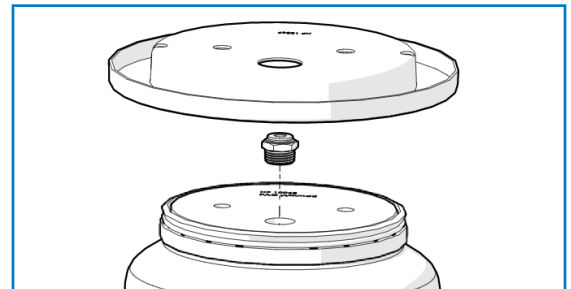

4

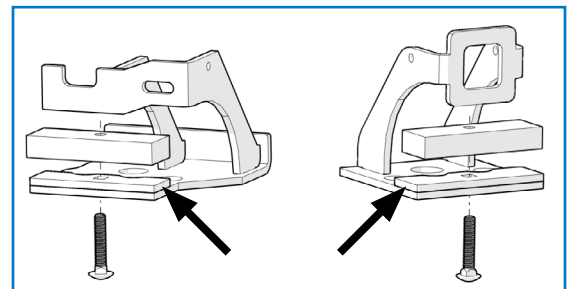

5A

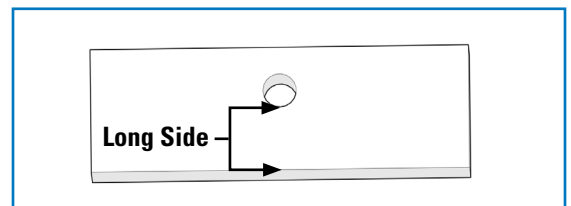

5B

7 ATTACH UPPER DRIVER BRACKET TO AIR SPRING

Assemble the driver side spring assembly (as shown in Figure 7A) by placing the upper driver bracket with spacer on the air spring and roll plate.

Align the bracket holes with the holes in the roll plate and air spring and secure using two 3/8" – 24 x 3/4" countersunk bolts.

Torque bolts to 27 N•m (20 ft-lbs).

Attach the L-Bracket to the hole in the upper driver bracket as shown in Figure 7B. Secure using a 1/4" – 20 x 1" bolt, two 1/4" flat washers and a 1/4" nylon lock nut.

Torque bolt to 8 N•m (6 ft-lbs).

8 INSTALL PASSENGER SPRING ASSEMBLY

Install the passenger spring assembly onto the truck (as shown in Figure 8A) by inserting the previously installed carriage bolt through the hole previously occupied by the jounce bumper bolt.

Secure using a 3/8" serrated flange nut and torque to 27 N•m (20 ft-lbs).

For trucks WITHOUT A FIFTH WHEEL HITCH:

Secure the upper bracket (as shown in Figure 8B on the following page) using a 1/2" – 13 x 1.25" bolt with two 1/2" x 2" OD thick flat washers, one 1/2" x 1.375" OD flat washer and one 1/2" serrated flange nut.

For trucks with a FACTORY FIFTH WHEEL HITCH:

Secure the upper bracket using the same method as above, however, replace the 1/2" x 1.375" OD flat washer that sits outside the frame with a 1/2" x 2" OD thin flat washer. The thinner washer is required in order for the serrated flange bolt to fit between the fifth wheel hitch plate and the frame.

For trucks with an AFTERMARKET FIFTH WHEEL HITCH THAT USES THE FRAME MOUNTING SLOTS:

Secure the upper bracket using the existing fifth wheel hardware previously removed in Step 3. When reinstalling hardware, add a 1/2" x 2" OD thick flat washer or 3/4" flat washer between the upper passenger bracket and the frame. The washer size needed will depend on the size of the fifth wheel bolt used.

Step continues on following page...

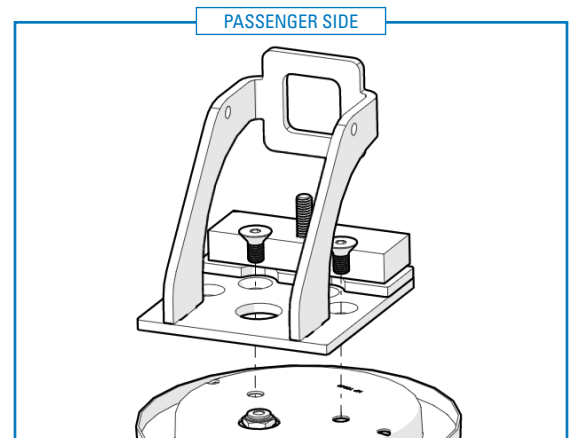

6

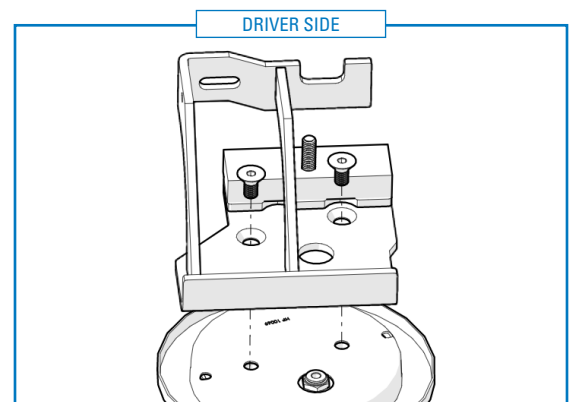

7A

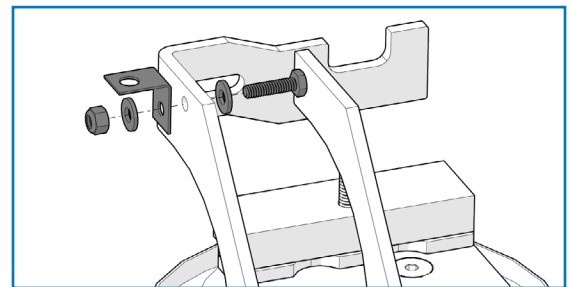

7B

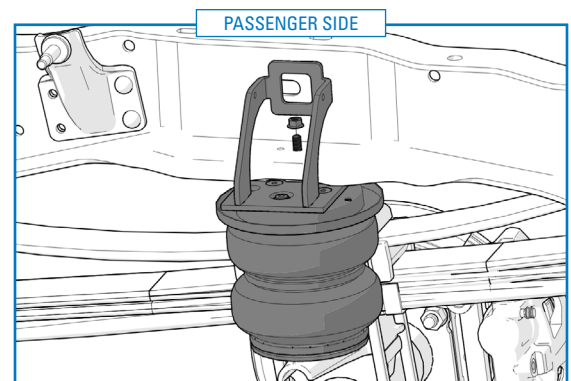

8A

For trucks with an AFTERMARKET FIFTH WHEEL HITCH THAT COVERS THE FRAME MOUNTING SLOTS:

A 1/2" hole must be drilled through the fifth wheel plate using the frame slot as a reference template.

! *PLEASE NOTE: It may be necessary to mark the drill location and remove the spring assembly to correctly drill the hole. Use caution when drilling to not damage any wiring lines, fuel lines or other vehicle components.*

Secure the upper bracket (as shown in Figure 8B) using a 1/2" – 13 x 3" bolt with two 1/2" x 2" OD thick flat washers, one 1/2" x 1.375" OD flat washer and one 1/2" serrated flange nut.

For all mounting conditions, torque bolt to 37 N•m (27 ft-lbs).

9 INSTALL DRIVER SPRING ASSEMBLY

Install the driver spring assembly onto the truck (as shown in Figure 9A) by inserting the previously installed carriage bolt through the hole previously occupied by the jounce bumper bolt.

Ensure no lines are pinched between the frame and bracket and secure using a 3/8" serrated flange nut.

Torque flange nut to 27 N•m (20 ft-lbs).

Secure the bracket to the frame (as shown in Figure 9B) using a 5/16" – 24 x 1" hex bolt, two 5/16" flat washers and a 5/16" nylon lock nut.

Torque bolt to 22 N•m (16 ft-lbs).

If the truck is equipped with an emission line, install the line clip into the hole in the L-bracket previously install in Step 7 (Figure 7B) on the upper driver bracket.

+ *PLEASE NOTE: L-bracket may need to be removed and positioned on the inner bracket surface to allow better fitment.*

For trucks WITHOUT A FIFTH WHEEL HITCH:

Secure the upper bracket (as shown in Figure 9C) using a 1/2" – 13 x 1.25" bolt with two 1/2" x 1.375" OD flat washers and one 1/2" serrated flange nut.

Step continues on following page...

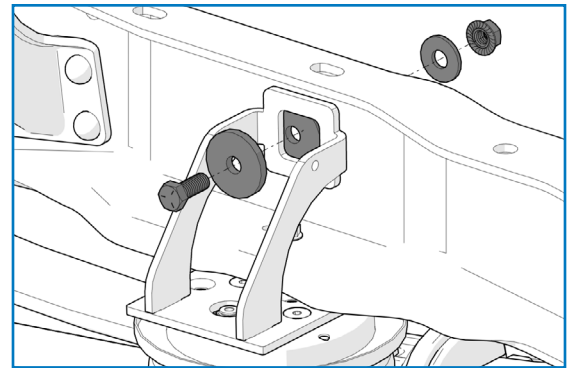

8B

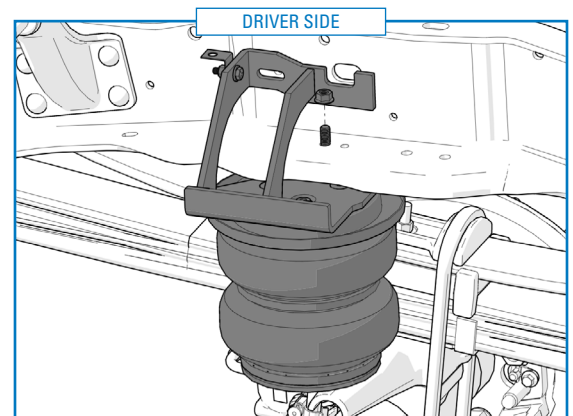

9A

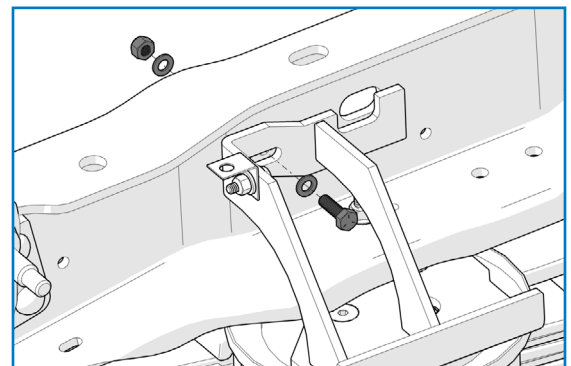

9B

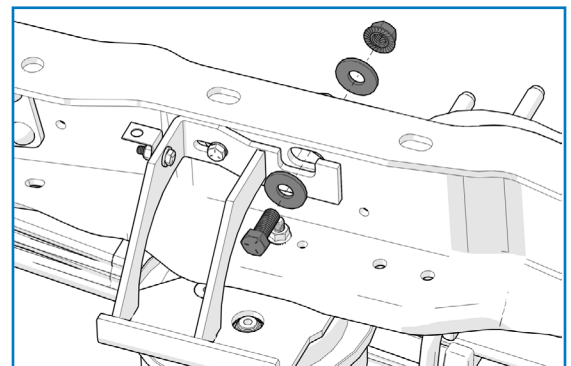

9C

For trucks with a FACTORY FIFTH WHEEL HITCH:

Secure the upper bracket using the same method as above, however, replace the 1/2" x 1.375" OD flat washer that sits outside the frame with a 1/2" x 2" OD thin flat washer. The thinner washer is required in order for the serrated flange bolt to fit between the fifth wheel hitch plate and the frame.

For trucks with an AFTERMARKET FIFTH WHEEL HITCH THAT USES THE FRAME MOUNTING SLOTS:

Secure the upper bracket using the existing fifth wheel hardware removed in Step 3.

For trucks with an AFTERMARKET FIFTH WHEEL HITCH THAT COVERS THE FRAME MOUNTING SLOTS:

A 1/2" hole must be drilled through the fifth wheel plate using the frame slot as a reference template.

- !** **PLEASE NOTE:** *It may be necessary to mark the drill location and remove the spring assembly to correctly drill the hole. Use caution when drilling to not damage any wiring lines, fuel lines or other vehicle components.*

Secure the upper bracket (as shown in Figure 9C on the previous page) using a 1/2" – 13 x 3" bolt with two 1/2" x 1.375" OD flat washers and one 1/2" serrated flange nut.

For all mounting conditions, torque bolt to 37 N•m (27 ft-lbs).

10 PRE-ASSEMBLE LOWER BRACKETS

Assemble the lower brackets (as shown in Figure 10).

Attach the lower axle bracket and lower air spring bracket using four 3/8" – 16 x 1.5" bolts, eight 3/8" flat washers and four 3/8" nylon lock nuts.

- !** **Ensure bolts are inserted from the inside or they will cause interference on trucks equipped with lift blocks.**

Do not fully tighten hardware to allow for adjustability during install.

11 INSTALL LOWER BRACKET ASSEMBLY

Place lower bracket assembly in truck (as shown in Figure 11).

If the truck is equipped with a lift block, ensure the air spring bracket is positioned above the block as shown.

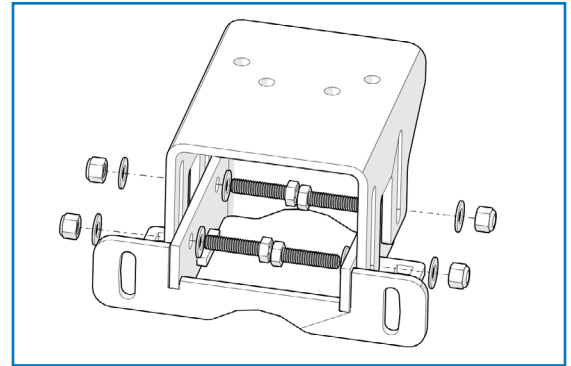

10

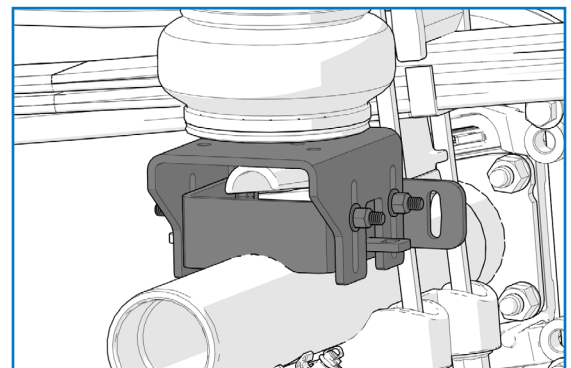

11

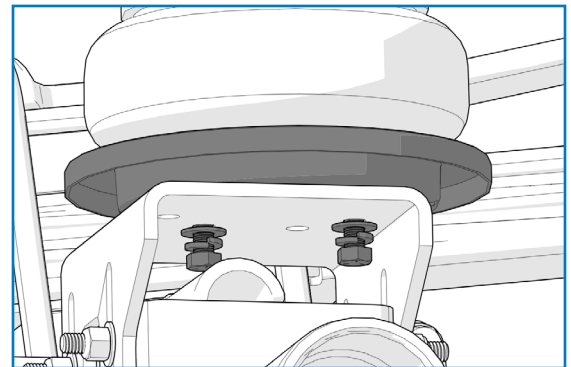

12



13

12 INSTALL LOWER ROLL PLATE AND SECURE AIR SPRING

Insert a roll plate between the air spring and lower bracket (as shown in Figure 12 on the previous page). Align the holes in the air spring, roll plate and air spring bracket and secure using two 3/8" – 24 x 7/8" bolts, two 3/8" lock washers and two 3/8" flat washers.

Torque bolts to 27 N•m (20 ft-lbs).

13 INSTALL LOWER BRACKET U-BOLT

Install the square U-Bolt around the leaf pack and into the axle bracket (as shown in Figure 13 on the previous page). Secure using two 3/8" flat washers and two 3/8" nylon lock nuts.

Torque nuts to 27 N•m (20 ft-lbs).

14 INSTALL AXLE CLAMP

Insert a 3/8" – 16 x 6" carriage bolt into each of the square holes on the lower axle bracket. Attach the axle strap to the carriage bolts as shown in Figure 14 using two 3/8" flat washers and two 3/8" nylon lock nuts.

Torque nuts to 27 N•m (20 ft-lbs).

15 SET AIR SPRING BRACKET HEIGHT

For vehicles WITH a lift block, lower the air spring bracket until it just touches the lift block (shown in Figure 15). Torque the four hex bolts to 51.5 N•m (38 ft-lbs) to lock this height.

For vehicles WITHOUT a lift block, lower the air spring bracket to the lowest possible position that does not result in interference with other components. Torque the four hex bolts to 51.5 N•m (38 ft-lbs)

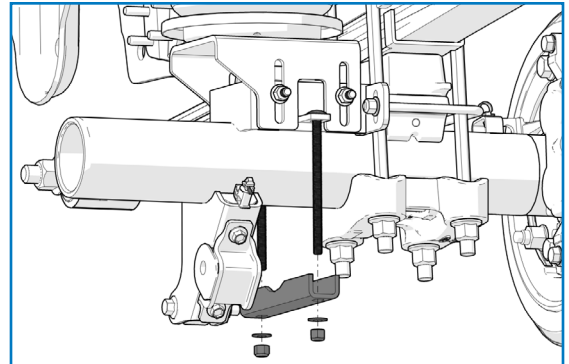

14

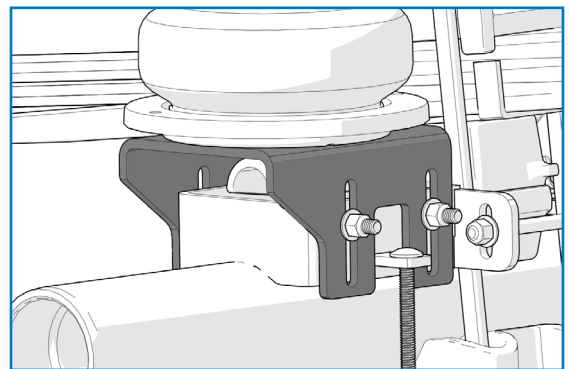

15

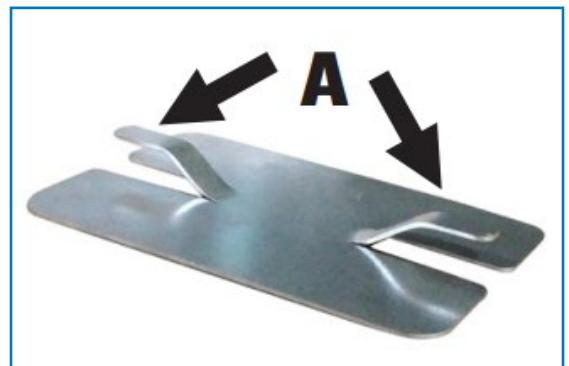

16A

16 ATTACH HEAT SHIELD TO MUFFLER

Bend the tabs on the heat shield (as shown with the arrows in Figure 16A) so there will be the necessary 1/2" dead space between the heat shield and the muffler when the heat shield is attached.

Attach the heat shield to the muffler (as shown with the arrow in Figure 16B) using two hose clamps. Each hose clamp holds a tab against the muffler. Make sure the heat shield is facing toward the air spring.

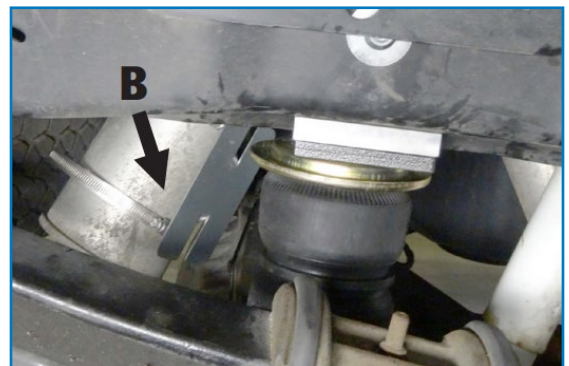

16B

INSTALL AIR LINE

Two fill valves are provided in this kit. The most common place to install them is in place of the license plate fasteners. Alternatively, two 5/16" holes can be drilled in a location of your choosing.

Cut the air line assembly into two equal lengths with the hose cutter provided in this kit or a sharp utility knife.

! **PLEASE NOTE:** *This kit contains push-to-connect fittings; using scissors or wire cutters to cut the nylon air line will distort the line and cause the connection to leak. The air line must be cut off squarely with a hose cutter or a sharp utility knife.*

Install one air line at a time starting at the fill valve location. Place a 5/16" nut on the air valve. Leave enough of the inflation valve in front of the nut to extend through the hole, install a flat washer, and 5/16" nut and cap (reference Figure A for assembly). There should be enough valve exposed after installation – approximately 1/2" – to easily apply a pressure gauge or an air chuck.

Route the air line back to the NPT fitting on the air spring, then cut the hose to length. Moisten the end of the air line prior to inserting it into the fitting and push it in until it stops.

Repeat with the other fill valve.

Secure the air lines using the provided tie-straps, away from any moving items and heat sources.

CHECK SYSTEM FOR LEAKS

Inflate both air springs to 90 psi (60 psi for in-coil bags), then use a mixture of dish soap and water on all air line connections to detect any air leaks. Large, expanding bubbles indicate a leak (as shown in Figure B).

Repair as necessary and retest.

Inflate air springs to a predetermined value and on following day recheck pressure. If one or both of air springs have lost pressure, an air leak is present.

! **Leak must be repaired, and then retested until no leaks exist.**

CONGRATULATIONS! You have completed the install

After Installation continues on the following page.

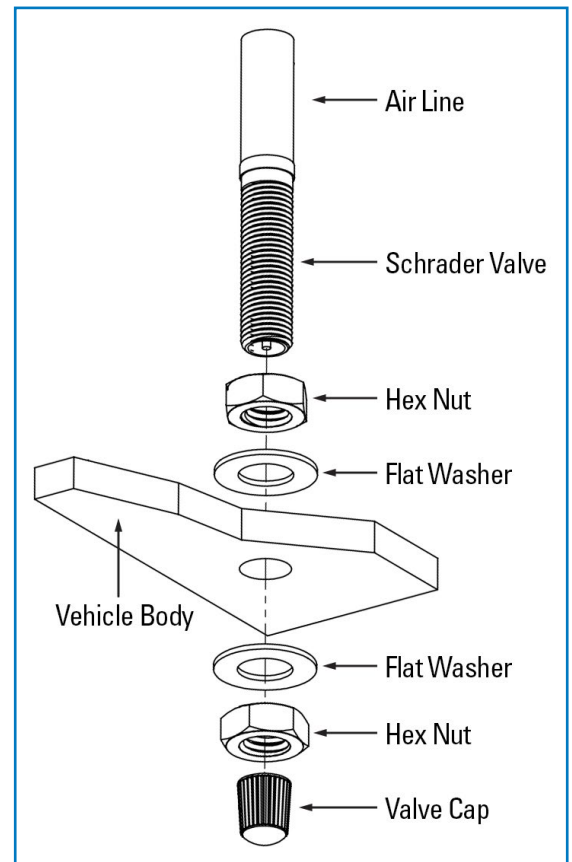

A

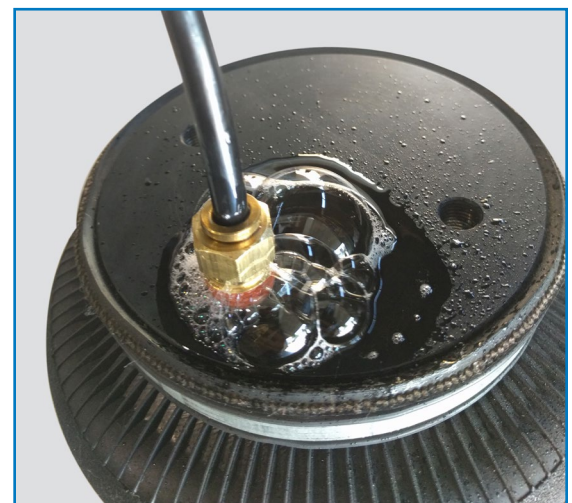

*Air Spring & NPT Air Fitting may differ between kits

B

Thank you again, and congratulations on the installation of your Air Suspension kit.

AFTER COMPLETING THE INSTALLATION

- The air spring must have clearance between itself and the surrounding components to prevent any contact when spring is inflated or compressed. Trimming off excess bolt length may also be required to ensure no contact with the spring or other suspension components can be made once installed.
- If removed, re-install the wheels and torque fasteners to the manufacturer’s specifications. Re-torque all fasteners after the first 500 miles of driving.

OPERATING YOUR VEHICLE WITH AIR SUSPENSION

Air springs have minimum and maximum recommended pressure requirements:

PART #	SPRING STYLE	SPRING TYPE	MIN PSI	MAX PSI
HP10189	In-Coil	STANDARD DUTY	5 PSI	70 PSI
HP10560		STANDARD DUTY		
HP10001	Sleeve Style	STANDARD DUTY	10 PSI	100 PSI
HP10173		STANDARD DUTY		
HP10199		STANDARD DUTY		
HP10083	Single Convoluted	HEAVY DUTY	5 PSI	100 PSI
HP10083J		HEAVY DUTY with JOUNCE BUMPER	0 PSI* / 5 PSI	100 PSI
HP10000	Double Convoluted	HEAVY DUTY	5 PSI	100 PSI
HP10000J		HEAVY DUTY with JOUNCE BUMPER	0 PSI* / 5 PSI	100 PSI
HP10068	Large Double Convoluted	HEAVY DUTY	5 PSI	100 PSI
HP10438	Double Convoluted	EXTREME DUTY	5 PSI	100 PSI
HP10438J		EXTREME DUTY with JOUNCE BUMPER	0 PSI* / 5 PSI	100 PSI

** Springs with a jounce bumper can be run at zero PSI when vehicle is unloaded only*

For safe and proper operation, never operate the vehicle over the maximum listed PSI in the air springs. Staying under the pressure limit will ensure maximum air spring life. **Failure in doing so may result in damage to your vehicle and/or a void warranty.**

! It is recommended to check the air pressure in your air springs daily for first couple of days to ensure a leak has not developed.

Air springs are designed to maintain the vehicle’s stock ride height with a load. Do not use the air springs as a means to lift vehicle with no load. This will result in a harsh ride.

SERVICING YOUR VEHICLE WITH AIR SUSPENSION

When lifting the vehicle with a floor jack or hoist on the frame, never allow the air spring to limit the travel of the axle. Try to always jack the vehicle on the axle. Suspending the axle with the air spring limiting the axle travel will damage the air spring and void the air spring warranty.

WARRANTY

See additional warranty included with this kit for details.

Installation Manual

STAINLESS UPGRADE KITS

COMPATIBLE WITH ALL 5000lbs & 7500lbs AIR SPRING KITS

Upgrade any Air Suspension kit with stainless steel fittings & hardware for premium corrosion-resistance, added durability, and a dependable strong hold that you can count on for much longer, that will withstand the stress of everyday abuse.

IMPORTANT

An air suspension kit will not increase the GVWR (*Gross Vehicle Weight Rating*), as the GVWR is determined by the vehicle manufacturer. **Do not exceed the maximum capacity listed by the vehicle manufacturer.**

For safe and proper operation of the vehicle, never exceed a maximum of 100PSI in the air springs. Staying under the pressure limit will ensure maximum air spring life. **Failure in doing so may result in damage to your vehicle and/or a void warranty.**

SAFETY WARNINGS!

- ❗ Please read and abide the instructions found in this manual, paying close attention to the helpful, cautionary or dangerous warning icons highlighting important safety recommendations and maintenance suggestions throughout this manual.

HELPFUL INSTALL TIP
Additional information that could potentially make the job a little easier.

PLEASE USE CAUTION
Unsafe practices could result in damage to you or your vehicle, or others.

DANGER WARNING
Hazards which could result in severe personal injury or death.

- ❗ Serious personal injury or death may result from an air spring failure or accident due to improper installation or air spring pressure operation or maintenance.
- ❗ Inflating an unsecured air spring is dangerous. If it bursts, it could be hurled into the air with explosive force resulting in serious personal injury or death. Never inflate an air spring unless it is secured to the vehicle.
- ❗ Removing and replacing air springs can be dangerous. This is only a job for a qualified service professional. Never perform air spring service procedures without proper training, tools, and equipment.

INTRODUCTION

The items included in the Stainless Steel Upgrade kit(s) are intended to replace the air line, air fittings, Schrader valves and (in some kits) roll plates, in compatible 5000lbs and 7500lbs Air Suspension kits.

Please confirm the items on the following *Kit Contents* page are provided in your kit before starting the installation.

Parts included in this kit are a direct upgrade/replacement to parts included in an Air Suspension kit (sold separately). A crossover replacement parts list can be found on the following *Kit Contents* page. Please note that this kit includes extra hardware in order to accommodate many kit applications — there will be hardware left over after you complete the installation.

Installation instructions for installing the braided stainless steel air lines are included in this manual. Otherwise this manual is to be used as a supplementary piece to your existing manual included with your Air Suspension kit.

FOR PREVIOUSLY INSTALLED AIR SUSPENSION KITS

This kit may require additional clearance between the top of the air spring and upper bracket in order to properly install the new fittings and braided stainless steel air lines in certain applications.

- ❗ It is recommended to verify that there is adequate clearance to install the air line components to avoid difficulty during the installation.
- ❗ In order to install the upgraded roll plates and air spring hardware, the air spring assembly must be removed from the vehicle.
- ❗ Check the condition of the existing hardware before removing.

KIT CONTENTS

STAINLESS AIR LINE UPGRADE		QTY	PART #	REPLACES
A	Air Line, Braided – 6 Feet	2	HP2048	HP1344*
B	Fitting, 1/4" NPT – Straight	2	HP2031	HP1099
C	Fitting, 1/4" NPT – Swivel Elbow	2	HP2032	HP1100
D	Fitting, 1/4" PTC – Straight	2	HP2033	HP1098
E	Fitting, Schrader	2	HP2045	HP1344*
F^A	Fitting, 3/8" to 1/4" NPT Bushing	2	HP2049	—
G	Washer, M8 Flat	2	HP2046	HP1344*
H	Washer, M8 Lock	2	HP2047	HP1344*
	Zip Tie (<i>included, not shown</i>)	12	C11618	—



STAINLESS 5000 _{lbs} UPGRADE		QTY	PART #	REPLACES
A	Air Line, Braided – 6 Feet	2	HP2048	HP1344*
B	Fitting, 1/4" NPT – Straight	2	HP2031	HP1099
C	Fitting, 1/4" NPT – Swivel Elbow	2	HP2032	HP1100
D	Fitting, 1/4" PTC – Straight	2	HP2033	HP1098
E	Fitting, Schrader	2	HP2045	HP1344*
G	Washer, M8 Flat	2	HP2046	HP1344*
H	Washer, M8 Lock	2	HP2047	HP1344*
I	Bolt, 3/8"-24 x 7/8" Hex Head	8	HP2050	HP1002
J	Bolt, 3/8"-24 x 3/4" Button Head	8	HP2051	HP1977
K	Bolt, 3/8"-24 x 3/4" Flat Head	8	HP2052	HP1008
L	Washer, 3/8" Flat	8	HP2053	C18006 / C653
M	Washer, 3/8" Lock	8	HP2054	C18007
N	Roll Plate, 5000 lb	4	HP10054-SS	HP10054
	Zip Tie (<i>included, not shown</i>)	12	C11618	—



STAINLESS 7500 _{lbs} UPGRADE		QTY	PART #	REPLACES
A	Air Line, Braided – 6 Feet	2	HP2048	HP1344*
B	Fitting, 1/4" NPT – Straight	2	HP2031	HP1099
C	Fitting, 1/4" NPT – Swivel Elbow	2	HP2032	HP1100
D	Fitting, 1/4" PTC – Straight	2	HP2033	HP1098
E	Fitting, Schrader	2	HP2045	HP1344*
F^A	Fitting, 3/8" to 1/4" NPT Bushing	2	HP2049	—
G	Washer, M8 Flat	2	HP2046	HP1344*
H	Washer, M8 Lock	2	HP2047	HP1344*
I	Bolt, 3/8"-24 x 7/8" Hex Head	8	HP2050	HP1002
J	Bolt, 3/8"-24 x 3/4" Button Head	8	HP2051	HP1977
K	Bolt, 3/8"-24 x 3/4" Flat Head	8	HP2052	HP1008
L	Washer, 3/8" Flat	8	HP2053	C18006 / C653
M	Washer, 3/8" Lock	8	HP2054	C18007
O	Roll Plate, 7500 lb	4	HP10069-SS	HP10069
	Zip Tie (<i>included, not shown</i>)	12	C11618	—



PLEASE NOTE: This kit includes extra hardware in order to accommodate many kits — there will be hardware left over after installation.

***HP1344** is an air line hose assembly that comes preassembled in all Air Suspension kits. It is replaced by individual Stainless Steel parts in these upgrade kits.

F^A Only installed with 7500 lbs air spring kits.

INSTALLATION INSTRUCTIONS

HARDWARE AND ROLL PLATES

This section only applies to **Stainless 5000 lbs & 7500 lbs Upgrade Kits.**

1.1 Locate and reference the installation guide that came with the original Air Suspension kit.

+ You may need to contact your original point of purchase.

Skip Steps 1.2 and 1.3 if there is no air suspension kit currently installed on the vehicle.

1.2 Exhaust all air from the system. See **Replacing Existing Nylon Air Lines** section on the following page.

1.3 Remove the air spring from the brackets, following the steps in the original air suspension kit's installation manual, in the reverse order.

1.4 There are three styles of air spring mounting hardware included in both the Stainless 5000lbs & 7500lbs Upgrade Kits, (see Figure 1.4).

Determine which bolt style is required for the air suspension kit by referencing the *Kit Contents* and *Explosion Diagram* sections in the installation manual that came with the air suspension kit.

+ Air suspension kits may require different fastener types to secure each end of the air spring to air suspension bracketry.

1.5 Using the stainless steel hardware previously identified in Step 1.4, follow the instructions for the air suspension kit.

Refer to this manual in lieu of the original air suspension kit manual on steps that refer to air fittings and air lines.

All fastener hardware used to secure the air spring to air suspension bracketry should be torqued to 27 N•m [20 ft-lbs] unless otherwise specified in the air suspension kit installation manual.

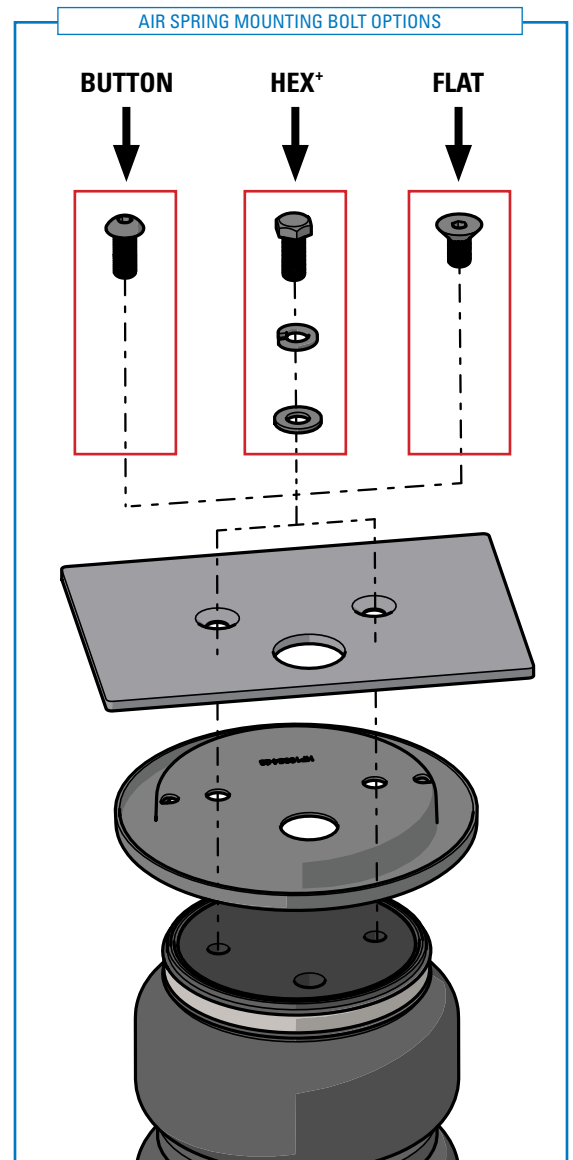

1.4 **HEX Bolts require additional 3/8" Flat and Lock Washers when being used for an installation.*

REPLACING EXISTING NYLON AIR LINES

This section applies to all Stainless Upgrade Kits.

- 2.1** Exhaust all air from the system, either with the Schrader valves or the air control system (if equipped).
- !** **PLEASE NOTE:** *If the vehicle has an air control system, remove the fuse connected to the ignition power source to prevent the system from trying to inflate the air spring while working on the vehicle.*
- 2.2** To disconnect push-to-connect (PTC) fittings (using Figure 2.2 as reference):
- STEP 1** Push in on the air line
 - STEP 2** Push the PTC fitting's collar inward
 - STEP 3** With the collar depressed pull the air line out of the fitting
- 2.3** If the other end of the nylon air line is connected to the vehicle body, remove the hose from the vehicle body and set the nylon air line aside.

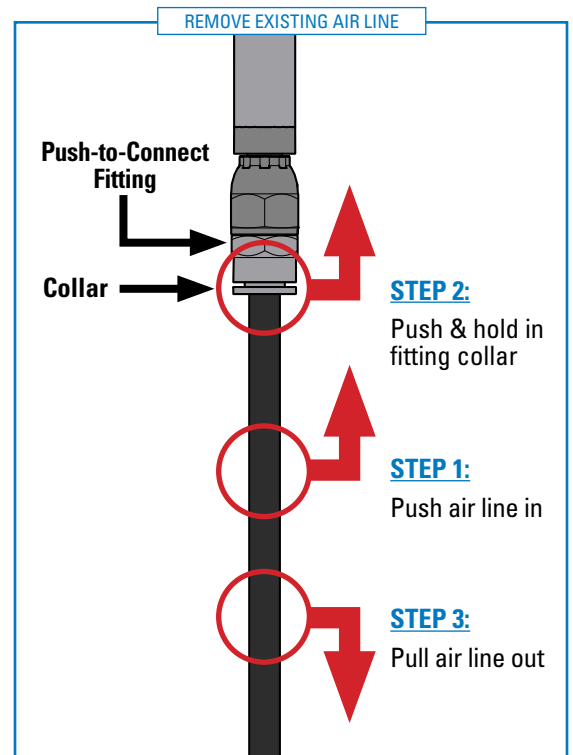

2.2

AIR FITTINGS

This section applies to all Stainless Upgrade Kits.

- 3.1** There are two types of air spring fittings provided in all Stainless Upgrade kits (see Figure 3.1). Identify the type of fitting required by referring to the installation manual for the air suspension kit.
- 3.2** Install the stainless steel air fitting (identified in Step 3.1) as instructed by the installation manual for the air suspension kit.
- +** *Teflon tape or thread sealant is recommended for all air fittings.*

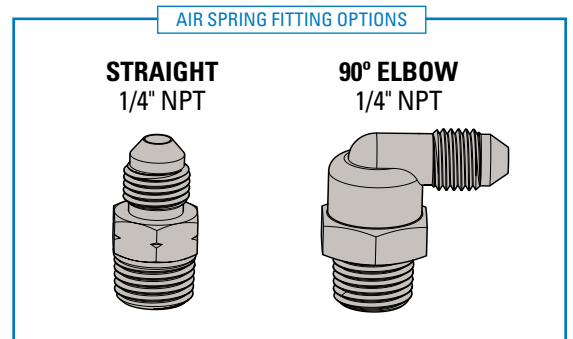

7500lbs bags require an additional 3/8" to 1/4" NPT adapter bushing (included in the Basic and 7500lbs kits) 3.1

For 5000 lbs Air Suspension kits: The air spring fitting should be threaded into the air spring finger tight, plus an additional 1.5 turns.

For 7500 lbs Air Suspension kits: Thread the air spring fitting into the supplied 3/8" to 1/4" NPT adapter bushing (as shown in Figure 3.2) finger tight plus an additional 1.5 turns. Then thread the combined fitting and bushing into the air spring finger tight plus an additional 1.5 turns.

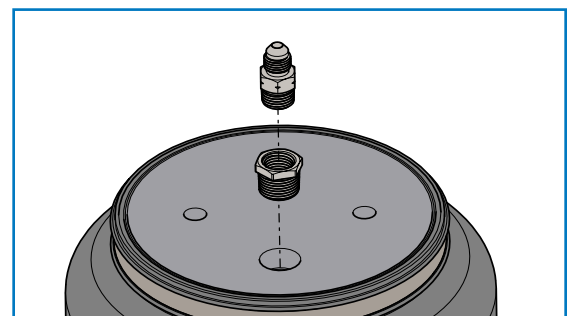

3.2

BRAIDED STAINLESS STEEL AIR LINES

This section applies to all **Stainless Upgrade Kits**.

- ⊕ *The braided stainless steel air line cannot be trimmed.*
- ! *Keep the air line away from the fuel line, brake lines and electrical wires.*

4.1 Install the air line to the air spring fittings.

Torque the braided stainless steel hose to 15 – 16 N•m [11 – 12 ft-lbs].

4.2 Use the supplied zip ties to secure the air line to fixed points along the chassis every 6" to 8" (152 to 203 mm) from the air spring to the fill location.

Leave at least 2" (51 mm) of slack to allow for any movement that might pull on the air line.

4.3 If installing the air line without an air control system:

Two fill valves are provided in this kit. The most common place to install them is in place of the license plate fasteners.

Alternatively, two 5/16" holes can be drilled in a location of your choosing.

(Using Figure 4.3 for assembly reference) Install the stainless steel Schrader valve to the end of the stainless steel braided hose.

Torqued the hose-end to 15 – 16 N•m [11 – 12 ft-lbs].

- ⊕ *It is easiest to properly torque the hose ends before the Schrader valve is secured to the vehicle body.*

Place a 5/16" hex nut and a lock washer on the air valve. Leave enough of the inflation valve in front of the nut/lock washer to extend through the vehicle body, or alternative 5/16" hole of your choosing, then complete the assembly by installing a flat washer, hex nut, and a schrader valve cap.

There should be enough valve exposed after installation – approximately 1/2" – to easily apply a pressure gauge or an air chuck.

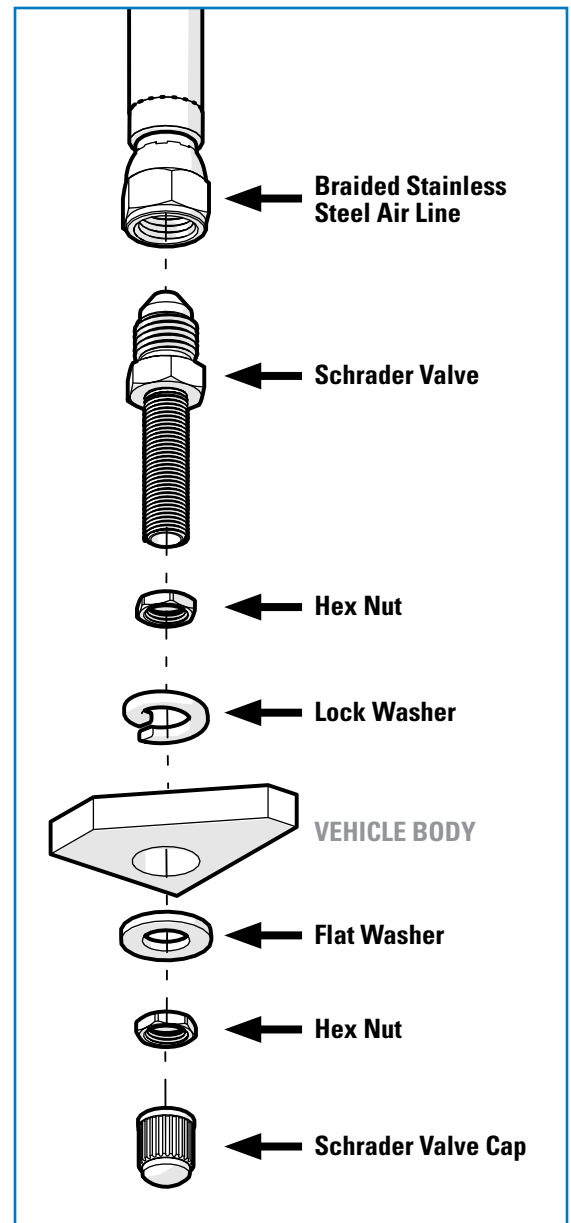

4.3

4.4 If installing the line with an air control system:

Install the stainless steel push-to-connect (PTC) fitting to the end of the stainless steel braided hose.

Torqued the hose-end to 15 – 16 N•m [11 – 12 ft-lbs].

Insert the nylon air hose, connected to the air control system, into the stainless steel PTC fitting.

Moisten the end of the nylon air line prior to inserting it into the fitting and push it in until it stops.

+ *You should feel 2 clicks which indicate a tight seal.*

4.5 Coil and secure any excess air line with the remaining zip ties, in an area where it will not be susceptible to damage.**5 CHECK SYSTEM FOR LEAKS**

Inflate both air springs to 90 psi, then use a mixture of dish soap and water on all air line connections to detect any air leaks.

Large, expanding bubbles indicate a leak (as shown in Figure 5).

Repair as necessary and retest.

Inflate air springs to a predetermined value and on following day recheck pressure.

If one or both of air springs have lost pressure, an air leak is present.

! *Leak must be repaired, and then retested until no leaks exist.*

CONGRATULATIONS! You have completed the install

After Installation continues on the following page.

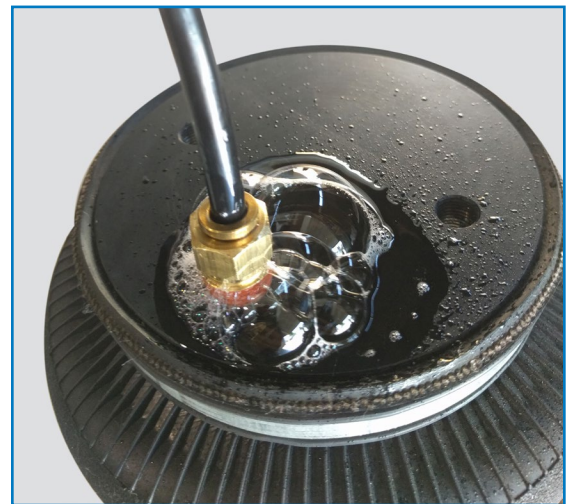

*Air Spring & NPT Air Fitting may differ between kits

B

Thank you again, and congratulations on the installation of your Air Suspension kit.

AFTER COMPLETING THE INSTALLATION

- The air spring must have clearance between itself and the surrounding components to prevent any contact when spring is inflated or compressed. Trimming off excess bolt length may also be required to ensure no contact with the spring or other suspension components can be made once installed.
- If removed, re-install the wheels and torque fasteners to the manufacturer’s specifications. Re-torque all fasteners after the first 500 miles of driving.

OPERATING YOUR VEHICLE WITH AIR SUSPENSION

Air springs have minimum and maximum recommended pressure requirements:

PART #	SPRING STYLE	SPRING TYPE	MIN PSI	MAX PSI
HP10189	In-Coil	STANDARD DUTY	5 PSI	70 PSI
HP10560		STANDARD DUTY		
HP10001	Sleeve Style	STANDARD DUTY	10 PSI	100 PSI
HP10173		STANDARD DUTY		
HP10199		STANDARD DUTY		
HP10083	Single Convoluted	HEAVY DUTY	5 PSI	100 PSI
HP10083J		HEAVY DUTY with JOUNCE BUMPER	0 PSI* / 5 PSI	100 PSI
HP10000	Double Convoluted	HEAVY DUTY	5 PSI	100 PSI
HP10000J		HEAVY DUTY with JOUNCE BUMPER	0 PSI* / 5 PSI	100 PSI
HP10068	Large Double Convoluted	HEAVY DUTY	5 PSI	100 PSI
HP10438	Double Convoluted	EXTREME DUTY	5 PSI	100 PSI
HP10438J		EXTREME DUTY with JOUNCE BUMPER	0 PSI* / 5 PSI	100 PSI

** Springs with a jounce bumper can be run at zero PSI when vehicle is unloaded only*

For safe and proper operation, never operate the vehicle over the maximum listed PSI in the air springs. Staying under the pressure limit will ensure maximum air spring life. **Failure in doing so may result in damage to your vehicle and/or a void warranty.**

! It is recommended to check the air pressure in your air springs daily for first couple of days to ensure a leak has not developed.

Air springs are designed to maintain the vehicle’s stock ride height with a load. Do not use the air springs as a means to lift vehicle with no load. This will result in a harsh ride.

SERVICING YOUR VEHICLE WITH AIR SUSPENSION

When lifting the vehicle with a floor jack or hoist on the frame, never allow the air spring to limit the travel of the axle. Try to always jack the vehicle on the axle. Suspending the axle with the air spring limiting the axle travel will damage the air spring and void the air spring warranty.

WARRANTY

See additional warranty included with this kit for details.