

Installation Manual



AIR SUSPENSION KIT

Ford Transit 150 / 250 / 350 (2WD/4WD) (SRW)*

Will not fit E-Transit models, 350HD or DRW models.

Use the most advanced air, springs on the market to eliminate your vehicle's sag, sway and bottoming out. This heavy duty air suspension kit levels your truck's stance while providing added support for an overall smooth and safe ride.

* See application guide for proper fitment.

L6444_REV5_02.18.2025 ECN 1-3011

Thank you and congratulations on the purchase of an Air Suspension kit. Please read the entire manual prior to starting the installation to ensure you can complete it once started.

IMPORTANT

An air suspension kit will not increase the GVWR (*Gross Vehicle Weight Rating*), as the GVWR is determined by the vehicle manufacturer. **Do not exceed the maximum capacity listed by the vehicle manufacturer.**

For safe and proper operation of the vehicle, never exceed a maximum of 100PSI in the air springs. Staying under the pressure limit will ensure maximum air spring life. **Failure in doing so may result in damage to your vehicle and/or a void warranty.**

SAFETY WARNINGS!

! Please read and abide the instructions found in this manual, paying close attention to the helpful, cautionary or dangerous warning icons highlighting important safety recommendations and maintenance suggestions throughout this manual.

+ **HELPFUL INSTALL TIP**
Additional information that could potentially make the job a little easier.

! **PLEASE USE CAUTION**
Unsafe practices could result in damage to you or your vehicle, or others.

! **DANGER WARNING**
Hazards which could result in severe personal injury or death.

! Serious personal injury or death may result from an air spring failure or accident due to improper installation or air spring pressure operation or maintenance.

! Inflating an unsecured air spring is dangerous. If it bursts, it could be hurled into the air with explosive force resulting in serious personal injury or death. Never inflate an air spring unless it is secured to the vehicle.

! Removing and replacing air springs can be dangerous. This is only a job for a qualified service professional. Never perform air spring service procedures without proper training, tools, and equipment.

BEFORE STARTING THE INSTALLATION

- Ensure the application information is correct for the make, model and year of the vehicle you are installing the kit on.
 - Some vehicles are equipped with a rear wheel brake proportioning valve. Check with the manufacturer before installing the air spring kit, as it may affect braking performance.
 - It is recommended to use a good quality anti-seize on all fasteners. This will reduce the chance of corrosion on the fasteners and will help facilitate removal, if required at a later date.
- !** **PLEASE NOTE:** *This kit contains push-to-connect fittings; using scissors or wire cutters to cut the nylon air line will distort the line and cause the connection to leak. The air line must be cut off squarely with the hose cutter provided in this kit, or a sharp utility knife. Failure to do so may void the warranty.*

! **WARNING:** This product can expose you to the chemical Hexavalent Chromate, which is known to the State of California to cause cancer and birth defects or other reproductive harm. **For more information go to www.P65Warnings.ca.gov**

KIT CONTENTS

Please confirm the items below are provided in your kit before starting the installation. Reference the kit explosion diagram on the following page for part assembly.

HEAVY DUTY KITS		QTY	PART #
A	Double Convoluted Spring	2	HP10000

HEAVY DUTY JOUNCE BUMPER KITS		QTY	PART #
B	Double Convoluted Spring w/ Jounce Bumper	2	HP10000J

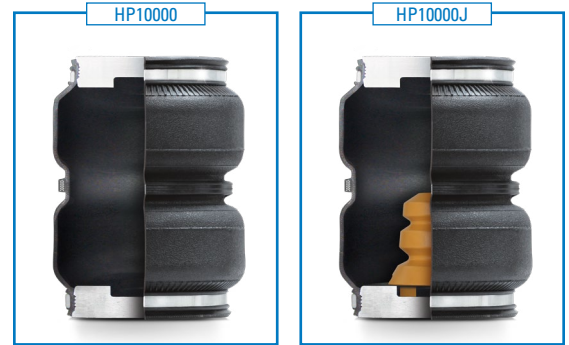

KIT CONTENTS		QTY	PART #
C	Roll Plate, 4.5" Diameter	4	HP10054
D	90° Swivel Fitting, 1/4" Hose To 1/4" NPT	2	HP1100
E	Frame Bracket	2	HP1500
F	Top Bracket	2	HP1501
G	Bottom Bracket	2	HP1502
H	Axle Strap	2	HP1383
I	Adel Clamp, 3/8"	2	HP1435
J	Bolt, 3/8" - 24 x 7/8" Hex Head	4	HP1002
K	Bolt, 3/8" - 24 x 3/4" Countersunk	4	HP1008
L	Bolt, 3/8" - 16 x 1.25" Carriage	4	HP1149
M	Bolt, 3/8" - 16 x 7" Carriage	4	HP1409
N	Bolt, M10 x 1.5 x 35mm Button Head	2	HP1414
O	Washer, 3/8" Flat	12	C18006
P	Nut, 3/8" Nylon Lock	8	HP1000
Q	Heat Shield	1	HP0012
R	Worm Gear Ring Clamp, 2.5" to 3.5"	2	HP1503
S	Worm Gear Ring Clamp, 3.5" to 4.5"	2	HP1001

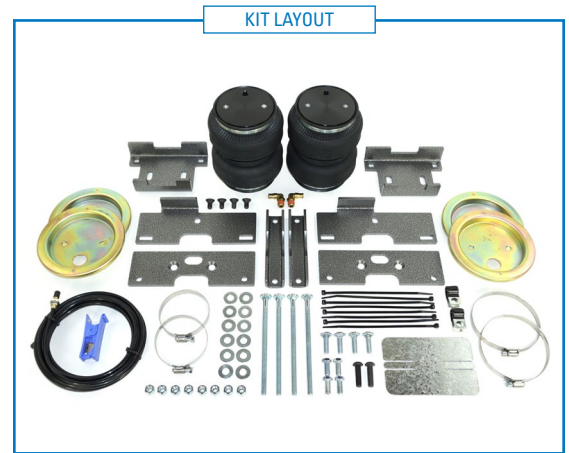

REQUIRED TOOLS

- Hoist or Floor Jack
- Safety Stands
- Safety Glasses
- Torque Wrench
- Standard Combination Wrenches
- 7/32" Hex Allen Wrench
- Ratchet
- Metric & Standard Sockets
- Hose Cutter (included) or Sharp Utility Knife
- Pipe Thread Sealant
- Spray Bottle with Dish Soap/Water
- Air Compressor/Compressed Air Source (to test/fill air springs)

KIT EXPLOSION DIAGRAM

DRIVER SIDE ASSEMBLY SHOWN (Passenger side assembly is mirrored)

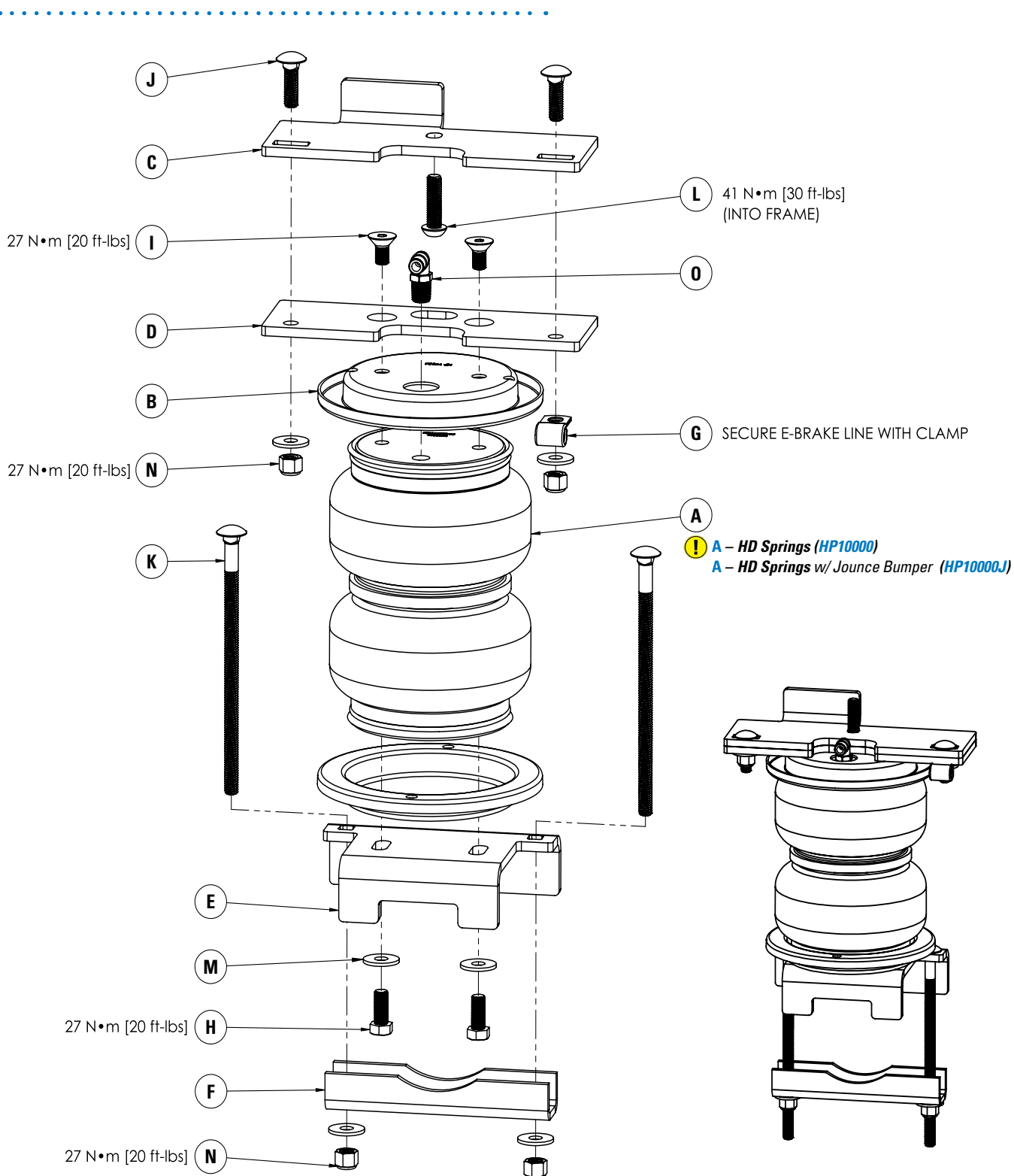

INSTALLATION INSTRUCTIONS

1 MEASURE STOCK RIDE HEIGHT & CLEARANCE

Park the vehicle on a level surface and remove any unnecessary weight from the vehicle to attain a "Normal Ride Height".

Using a measuring tape, measure the distance between the center of the wheel hub and the bottom of the fender well (see Figure 1A for reference) this will give you your stock Normal Ride Height.

Note the ride height for all four tires.

Check the clearance between the outside of the frame and the inside of the rear tires (as shown in red in Figure 1B), a minimum of 5" is required for adequate air spring clearance.

REMOVE REAR WHEELS

+ **PLEASE NOTE:** This step is optional for this installation but will make the install easier to complete.

Place wheel chocks in front of and behind both front wheels.

Raise the rear of the truck high enough to remove both wheels and attain a comfortable working height.

Place two jack stands under rear axle (as shown in Figure 1B).

Lower the vehicle until the axle is supported by the jack stands.

Remove rear wheels.

2 ASSEMBLING THE AIR SPRING:

Set a roll plate on top of the air spring (as shown Figure 2A).

Install the 90° swivel NPT fitting into the port on top of the air spring, finger tight plus 1 ½ turns.

! **CAUTION:** Never back off an installed NPT air fitting. Loosening the fitting will corrupt the seal and contribute leakage and failure.

+ Apply thread sealant to the fitting threads to prevent leaks and allow for deeper seating of the threads.

Set the top bracket on top of the air spring, and install two 3/8" – 24 x 7/8" Flat Head Socket Cap Screws (as shown in Figure 2B).

Torque to 27 N•m (20 ft-lbs).

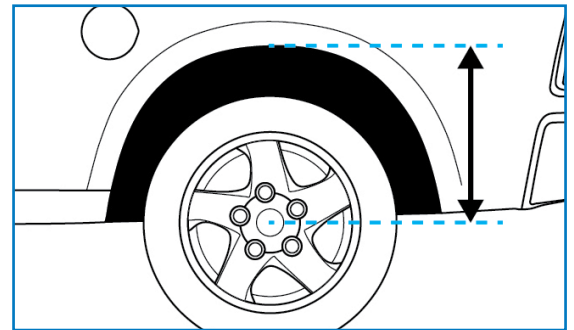

1A

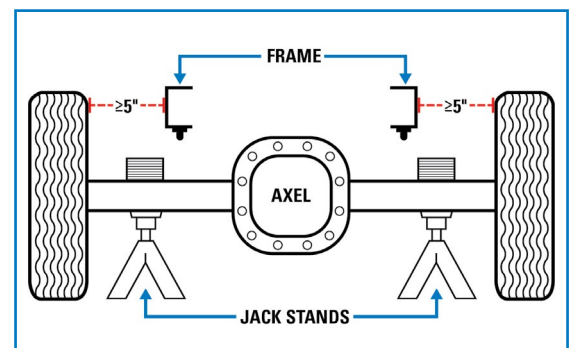

1B



2A



2B

Flip the assembly upside down and set a roll plate on the bottom of the air spring.

Insert the 3/8" – 24 x 7" carriage bolts into the bottom bracket square holes, (as shown in Figure 2C).

⊕ *Carriage bolts must be installed in the bottom bracket before attaching to the air spring assembly.*

Install the lower brackets onto the air spring assembly with two 3/8" – 24 x 7/8" Hex Head Cap Screws, two 3/8" flat washers.

Leave loose at this time for adjustments.

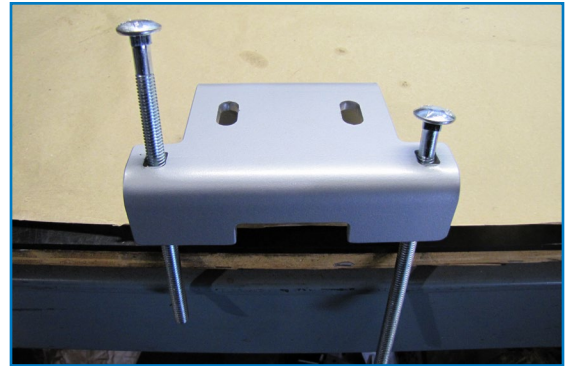

2C

3 PREP WORK:

Unbolt and remove the stock jounce bumpers from under the frame rails on both sides (see Figure 3A).

Insert two 3/8" – 16 X 1.25" carriage bolts through the frame bracket.

The head of the bolts should be on the flange side of the bracket (as shown in Figure 3B).

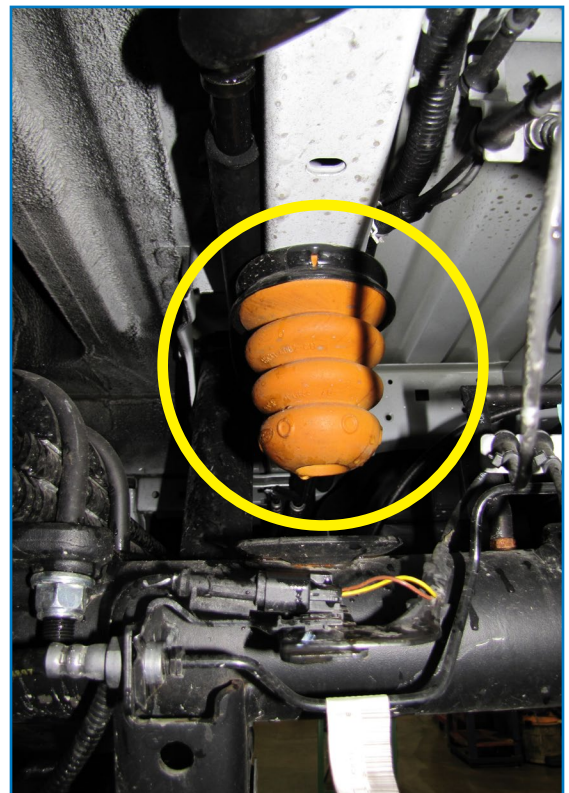

3A

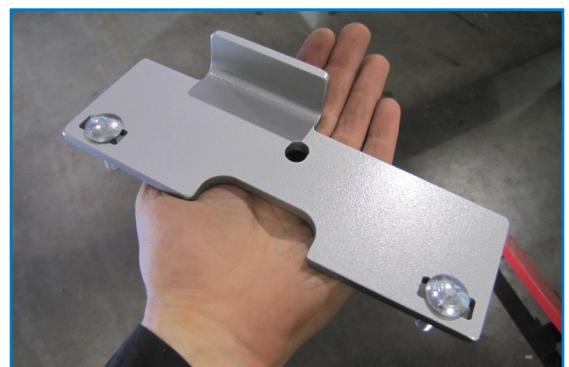

3B

4 INSTALLING THE AIR SPRING ASSEMBLIES:

Install the upper frame bracket assembly onto the underside of the frame using the M10 - 1.50 x 35 Button Head Screws making sure the flange on the bracket is on the inside of the frame rail and pointing up (as shown in Figure 4A).

Torque screws to 41 N•m (30 ft-lbs).

Lower the axle or raise the body to obtain enough clearance between the axle and the frame so that the air spring assemblies may be put into position.

Install both drivers and passengers side assemblies, making sure that the carriage bolt on the bottom bracket towards the rear of the vehicle is sitting between the brake/ABS lines and the axle (see Figure 4B).

+ *The air fitting on the assemblies face the outboard (tire side) of the vehicle also the lower bracket will be nested over the jounce bumper strike plate.*

Raise the axle or lower the body of the vehicle making sure that the carriage bolts previously installed in the frame bracket nests into the holes of the air spring top bracket.

On the rearward carriage bolts only, it will be necessary to install the cable clamps on both sides of the assemblies (see Figure 4C).

Cap all the carriage bolts with 3/8" washers and nylon lock nuts.

Leave them loose at this time.

Set the axle strap over the long carriage bolts hanging down under the axle with two 3/8" flat washers and 3/8" nyloc nuts.

Leave loose at this time.



4A

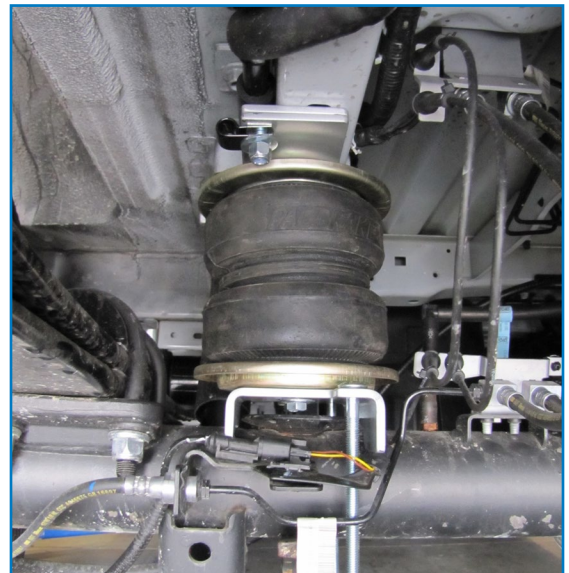

4B



4C

5 ADJUSTING THE AIR SPRING ASSEMBLIES

The air spring top bracket is slotted so that the air spring can be adjusted to the front or back, adjust the air spring so that it is sitting vertically straight (as shown in Figure 5).

Torque the upper hardware to 27 N•m (20 ft-lbs).

Once the lower bracket is parallel to the upper bracket, the axle strap on the lower bracket can be torqued evenly to 27 N•m (20 ft-lbs).

- ⊕ *It may be necessary to pull the brake line away from the carriage bolt slightly on the right hand side to gain clearance so the line will not rub on the bolt.*

Once the upper and lower brackets are tight, you will need to tighten the lower air spring mounting hardware on the lower brackets.

Slide the bellows along the slots of the lower bracket for the final alignment of the air spring.

Torque the lower mounting hardware to 27 N•m (20 ft-lbs).

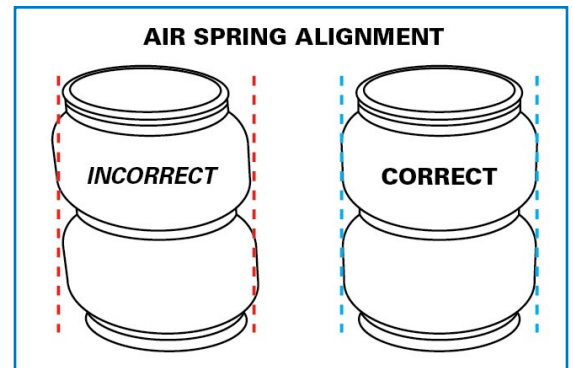

5

6 ADJUSTING ABS LINE

- ⚠ *On the driver side behind the axle, the ABS line may need to be adjusted so that it will not rub on the lower bracket.*

To do this pull the line out of the holder and rotate it 180° then push it back into the holder.

This will change the position of the line so that it will not come in contact with the lower bracket.

7 INSTALL HEAT SHIELD

Bend tabs on the heat shield so the required ½" of dead space exists between the heat shield and exhaust when attached.

Attach the heat shield to the exhaust pipe on passenger side using two ring clamps (shown in Figure 7).

Each hose clamp holds a tab against exhaust pipe.



7

INSTALL AIR LINE

Two fill valves are provided in this kit. The most common place to install them is in place of the license plate fasteners. Alternatively, two 5/16" holes can be drilled in a location of your choosing.

Cut the air line assembly into two equal lengths with the hose cutter provided in this kit or a sharp utility knife.

! ***PLEASE NOTE: This kit contains push-to-connect fittings; using scissors or wire cutters to cut the nylon air line will distort the line and cause the connection to leak. The air line must be cut off squarely with a hose cutter or a sharp utility knife.***

Install one air line at a time starting at the fill valve location. Place a 5/16" nut on the air valve. Leave enough of the inflation valve in front of the nut to extend through the hole, install a flat washer, and 5/16" nut and cap (reference Figure A for assembly). There should be enough valve exposed after installation – approximately 1/2" – to easily apply a pressure gauge or an air chuck.

Route the air line back to the NPT fitting on the air spring, then cut the hose to length. Moisten the end of the air line prior to inserting it into the fitting and push it in until it stops.

Repeat with the other fill valve.

Secure the air lines using the provided tie-straps, away from any moving items and heat sources.

CHECK SYSTEM FOR LEAKS

Inflate both air springs to 90 psi (60 psi for in-coil bags), then use a mixture of dish soap and water on all air line connections to detect any air leaks. Large, expanding bubbles indicate a leak (as shown in Figure B).

Repair as necessary and retest.

Inflate air springs to a predetermined value and on following day recheck pressure. If one or both of air springs have lost pressure, an air leak is present.

! ***Leak must be repaired, and then retested until no leaks exist.***

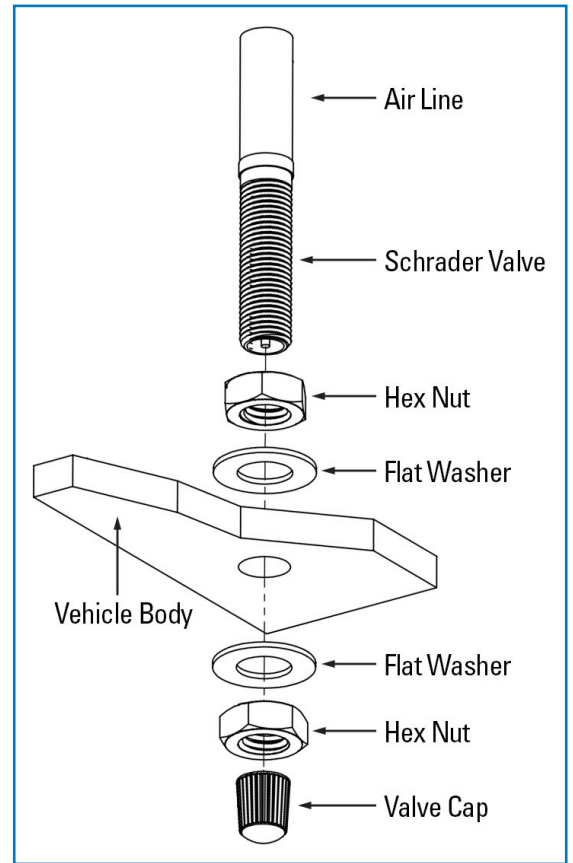

A

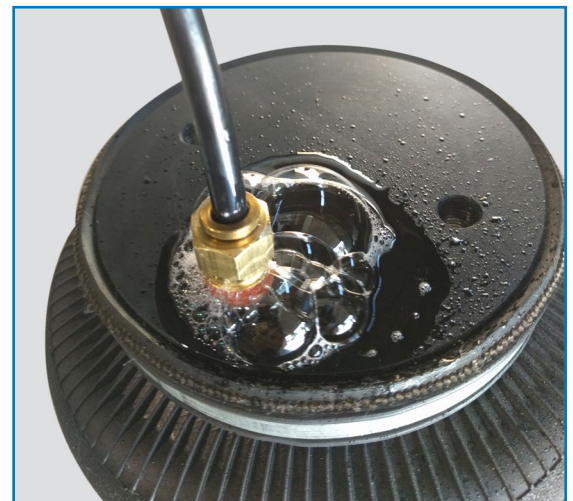

*Air Spring & NPT Air Fitting may differ between kits

B

CONGRATULATIONS! You have completed the install

After Installation continues on the following page.

Thank you again, and congratulations on the installation of your Air Suspension kit.

AFTER COMPLETING THE INSTALLATION

- The air spring must have clearance between itself and the surrounding components to prevent any contact when spring is inflated or compressed. Trimming off excess bolt length may also be required to ensure no contact with the spring or other suspension components can be made once installed.
- If removed, re-install the wheels and torque fasteners to the manufacturer’s specifications. Re-torque all fasteners after the first 500 miles of driving.

OPERATING YOUR VEHICLE WITH AIR SUSPENSION

Air springs have minimum and maximum recommended pressure requirements:

PART #	SPRING STYLE	SPRING TYPE	MIN PSI	MAX PSI
HP10189	In-Coil	STANDARD DUTY	5 PSI	70 PSI
HP10560		STANDARD DUTY		
HP10001	Sleeve Style	STANDARD DUTY	10 PSI	100 PSI
HP10173		STANDARD DUTY		
HP10199		STANDARD DUTY		
HP10083	Single Convoluted	HEAVY DUTY	5 PSI	100 PSI
HP10083J		HEAVY DUTY with JOUNCE BUMPER	0 PSI* / 5 PSI	100 PSI
HP10000	Double Convoluted	HEAVY DUTY	5 PSI	100 PSI
HP10000J		HEAVY DUTY with JOUNCE BUMPER	0 PSI* / 5 PSI	100 PSI
HP10068	Large Double Convoluted	HEAVY DUTY	5 PSI	100 PSI
HP10438	Double Convoluted	EXTREME DUTY	5 PSI	100 PSI
HP10438J		EXTREME DUTY with JOUNCE BUMPER	0 PSI* / 5 PSI	100 PSI

** Springs with a jounce bumper can be run at zero PSI when vehicle is unloaded only*

For safe and proper operation, never operate the vehicle over the maximum listed PSI in the air springs. Staying under the pressure limit will ensure maximum air spring life. **Failure in doing so may result in damage to your vehicle and/or a void warranty.**

! It is recommended to check the air pressure in your air springs daily for first couple of days to ensure a leak has not developed.

Air springs are designed to maintain the vehicle’s stock ride height with a load. Do not use the air springs as a means to lift vehicle with no load. This will result in a harsh ride.

SERVICING YOUR VEHICLE WITH AIR SUSPENSION

When lifting the vehicle with a floor jack or hoist on the frame, never allow the air spring to limit the travel of the axle. Try to always jack the vehicle on the axle. Suspending the axle with the air spring limiting the axle travel will damage the air spring and void the air spring warranty.

WARRANTY

See additional warranty included with this kit for details.

Installation Manual

STAINLESS UPGRADE KITS

COMPATIBLE WITH ALL 5000lbs & 7500lbs AIR SPRING KITS

Upgrade any Air Suspension kit with stainless steel fittings & hardware for premium corrosion-resistance, added durability, and a dependable strong hold that you can count on for much longer, that will withstand the stress of everyday abuse.

IMPORTANT

An air suspension kit will not increase the GVWR (*Gross Vehicle Weight Rating*), as the GVWR is determined by the vehicle manufacturer. **Do not exceed the maximum capacity listed by the vehicle manufacturer.**

For safe and proper operation of the vehicle, never exceed a maximum of 100PSI in the air springs. Staying under the pressure limit will ensure maximum air spring life. **Failure in doing so may result in damage to your vehicle and/or a void warranty.**

SAFETY WARNINGS!

- ❗ Please read and abide the instructions found in this manual, paying close attention to the helpful, cautionary or dangerous warning icons highlighting important safety recommendations and maintenance suggestions throughout this manual.

HELPFUL INSTALL TIP
Additional information that could potentially make the job a little easier.

PLEASE USE CAUTION
Unsafe practices could result in damage to you or your vehicle, or others.

DANGER WARNING
Hazards which could result in severe personal injury or death.

- ❗ Serious personal injury or death may result from an air spring failure or accident due to improper installation or air spring pressure operation or maintenance.
- ❗ Inflating an unsecured air spring is dangerous. If it bursts, it could be hurled into the air with explosive force resulting in serious personal injury or death. Never inflate an air spring unless it is secured to the vehicle.
- ❗ Removing and replacing air springs can be dangerous. This is only a job for a qualified service professional. Never perform air spring service procedures without proper training, tools, and equipment.

INTRODUCTION

The items included in the Stainless Steel Upgrade kit(s) are intended to replace the air line, air fittings, Schrader valves and (in some kits) roll plates, in compatible 5000lbs and 7500lbs Air Suspension kits.

Please confirm the items on the following *Kit Contents* page are provided in your kit before starting the installation.

Parts included in this kit are a direct upgrade/replacement to parts included in an Air Suspension kit (sold separately). A crossover replacement parts list can be found on the following *Kit Contents* page. Please note that this kit includes extra hardware in order to accommodate many kit applications — there will be hardware left over after you complete the installation.

Installation instructions for installing the braided stainless steel air lines are included in this manual. Otherwise this manual is to be used as a supplementary piece to your existing manual included with your Air Suspension kit.

FOR PREVIOUSLY INSTALLED AIR SUSPENSION KITS

This kit may require additional clearance between the top of the air spring and upper bracket in order to properly install the new fittings and braided stainless steel air lines in certain applications.

- ❗ It is recommended to verify that there is adequate clearance to install the air line components to avoid difficulty during the installation.
- ❗ In order to install the upgraded roll plates and air spring hardware, the air spring assembly must be removed from the vehicle.
- ❗ Check the condition of the existing hardware before removing.

KIT CONTENTS

STAINLESS AIR LINE UPGRADE		QTY	PART #	REPLACES
A	Air Line, Braided – 6 Feet	2	HP2048	HP1344*
B	Fitting, 1/4" NPT – Straight	2	HP2031	HP1099
C	Fitting, 1/4" NPT – Swivel Elbow	2	HP2032	HP1100
D	Fitting, 1/4" PTC – Straight	2	HP2033	HP1098
E	Fitting, Schrader	2	HP2045	HP1344*
F^A	Fitting, 3/8" to 1/4" NPT Bushing	2	HP2049	—
G	Washer, M8 Flat	2	HP2046	HP1344*
H	Washer, M8 Lock	2	HP2047	HP1344*
	Zip Tie (<i>included, not shown</i>)	12	C11618	—



STAINLESS 5000 _{lbs} UPGRADE		QTY	PART #	REPLACES
A	Air Line, Braided – 6 Feet	2	HP2048	HP1344*
B	Fitting, 1/4" NPT – Straight	2	HP2031	HP1099
C	Fitting, 1/4" NPT – Swivel Elbow	2	HP2032	HP1100
D	Fitting, 1/4" PTC – Straight	2	HP2033	HP1098
E	Fitting, Schrader	2	HP2045	HP1344*
G	Washer, M8 Flat	2	HP2046	HP1344*
H	Washer, M8 Lock	2	HP2047	HP1344*
I	Bolt, 3/8"-24 x 7/8" Hex Head	8	HP2050	HP1002
J	Bolt, 3/8"-24 x 3/4" Button Head	8	HP2051	HP1977
K	Bolt, 3/8"-24 x 3/4" Flat Head	8	HP2052	HP1008
L	Washer, 3/8" Flat	8	HP2053	C18006 / C653
M	Washer, 3/8" Lock	8	HP2054	C18007
N	Roll Plate, 5000 lb	4	HP10054-SS	HP10054
	Zip Tie (<i>included, not shown</i>)	12	C11618	—



STAINLESS 7500 _{lbs} UPGRADE		QTY	PART #	REPLACES
A	Air Line, Braided – 6 Feet	2	HP2048	HP1344*
B	Fitting, 1/4" NPT – Straight	2	HP2031	HP1099
C	Fitting, 1/4" NPT – Swivel Elbow	2	HP2032	HP1100
D	Fitting, 1/4" PTC – Straight	2	HP2033	HP1098
E	Fitting, Schrader	2	HP2045	HP1344*
F^A	Fitting, 3/8" to 1/4" NPT Bushing	2	HP2049	—
G	Washer, M8 Flat	2	HP2046	HP1344*
H	Washer, M8 Lock	2	HP2047	HP1344*
I	Bolt, 3/8"-24 x 7/8" Hex Head	8	HP2050	HP1002
J	Bolt, 3/8"-24 x 3/4" Button Head	8	HP2051	HP1977
K	Bolt, 3/8"-24 x 3/4" Flat Head	8	HP2052	HP1008
L	Washer, 3/8" Flat	8	HP2053	C18006 / C653
M	Washer, 3/8" Lock	8	HP2054	C18007
O	Roll Plate, 7500 lb	4	HP10069-SS	HP10069
	Zip Tie (<i>included, not shown</i>)	12	C11618	—



PLEASE NOTE: This kit includes extra hardware in order to accommodate many kits — there will be hardware left over after installation.

***HP1344** is an air line hose assembly that comes preassembled in all Air Suspension kits. It is replaced by individual Stainless Steel parts in these upgrade kits.

F^A Only installed with 7500 lbs air spring kits.

INSTALLATION INSTRUCTIONS

HARDWARE AND ROLL PLATES

This section only applies to **Stainless 5000 lbs & 7500 lbs Upgrade Kits**.

- 1.1** Locate and reference the installation guide that came with the original Air Suspension kit.

⊕ *You may need to contact your original point of purchase.*

Skip Steps 1.2 and 1.3 if there is no air suspension kit currently installed on the vehicle.

- 1.2** Exhaust all air from the system. See **Replacing Existing Nylon Air Lines** section on the following page.

- 1.3** Remove the air spring from the brackets, following the steps in the original air suspension kit's installation manual, in the reverse order.

- 1.4** There are three styles of air spring mounting hardware included in both the Stainless 5000lbs & 7500lbs Upgrade Kits, (see Figure 1.4).

Determine which bolt style is required for the air suspension kit by referencing the *Kit Contents* and *Explosion Diagram* sections in the installation manual that came with the air suspension kit.

⊕ *Air suspension kits may require different fastener types to secure each end of the air spring to air suspension bracketry.*

- 1.5** Using the stainless steel hardware previously identified in Step 1.4, follow the instructions for the air suspension kit.

Refer to this manual in lieu of the original air suspension kit manual on steps that refer to air fittings and air lines.

All fastener hardware used to secure the air spring to air suspension bracketry should be torqued to 27 N•m [20 ft-lbs] unless otherwise specified in the air suspension kit installation manual.

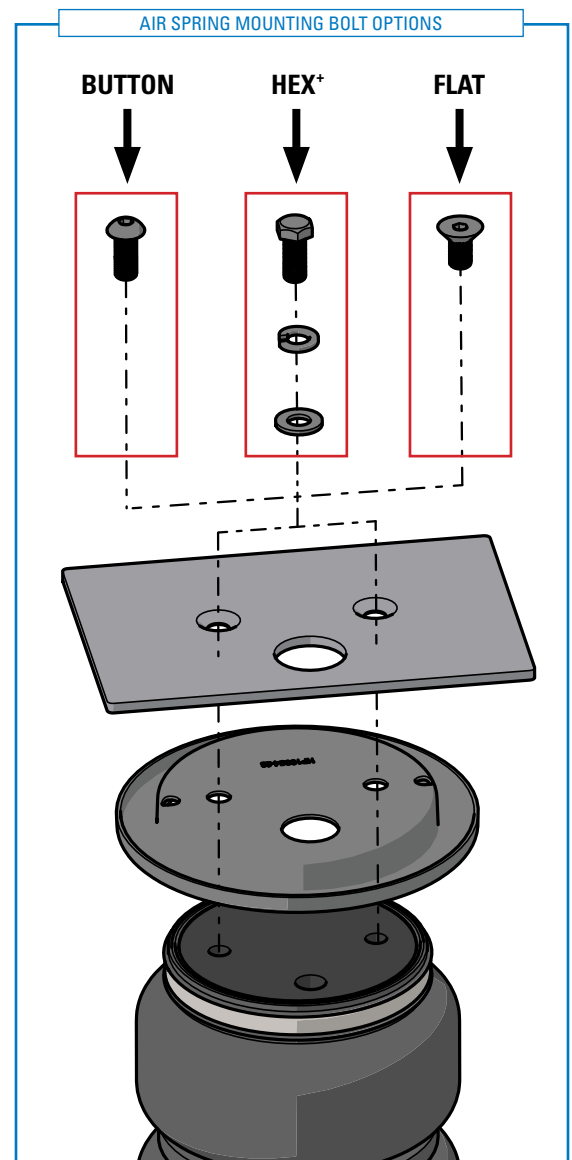

*HEX Bolts require additional 3/8" Flat and Lock Washers when being used for an installation.

1.4

REPLACING EXISTING NYLON AIR LINES

This section applies to all Stainless Upgrade Kits.

- 2.1** Exhaust all air from the system, either with the Schrader valves or the air control system (if equipped).
- !** **PLEASE NOTE:** If the vehicle has an air control system, remove the fuse connected to the ignition power source to prevent the system from trying to inflate the air spring while working on the vehicle.
- 2.2** To disconnect push-to-connect (PTC) fittings (using Figure 2.2 as reference):
- STEP 1** Push in on the air line
 - STEP 2** Push the PTC fitting's collar inward
 - STEP 3** With the collar depressed pull the air line out of the fitting
- 2.3** If the other end of the nylon air line is connected to the vehicle body, remove the hose from the vehicle body and set the nylon air line aside.

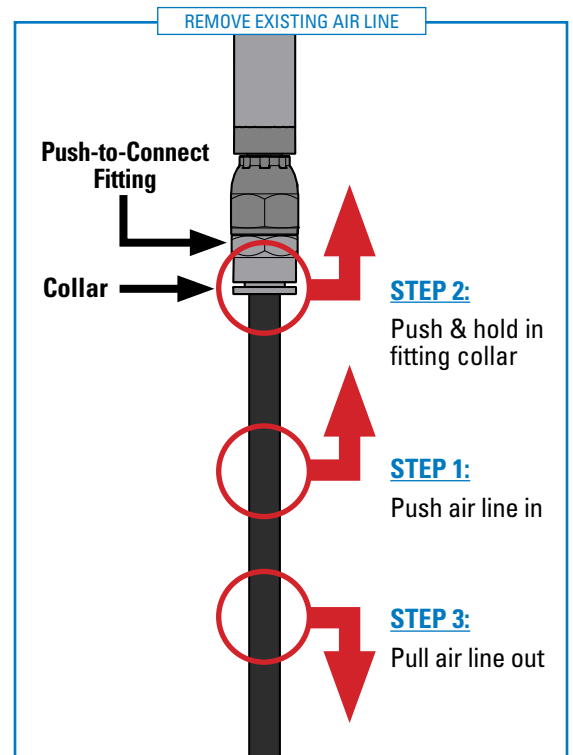

2.2

AIR FITTINGS

This section applies to all Stainless Upgrade Kits.

- 3.1** There are two types of air spring fittings provided in all Stainless Upgrade kits (see Figure 3.1). Identify the type of fitting required by referring to the installation manual for the air suspension kit.
- 3.2** Install the stainless steel air fitting (identified in Step 3.1) as instructed by the installation manual for the air suspension kit.
- +** Teflon tape or thread sealant is recommended for all air fittings.

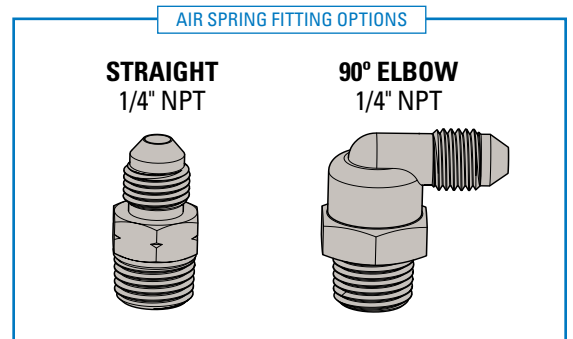

7500lbs bags require an additional 3/8" to 1/4" NPT adapter bushing (included in the Basic and 7500lbs kits)

3.1

For 5000 lbs Air Suspension kits: The air spring fitting should be threaded into the air spring finger tight, plus an additional 1.5 turns.

For 7500 lbs Air Suspension kits: Thread the air spring fitting into the supplied 3/8" to 1/4" NPT adapter bushing (as shown in Figure 3.2) finger tight plus an additional 1.5 turns. Then thread the combined fitting and bushing into the air spring finger tight plus an additional 1.5 turns.

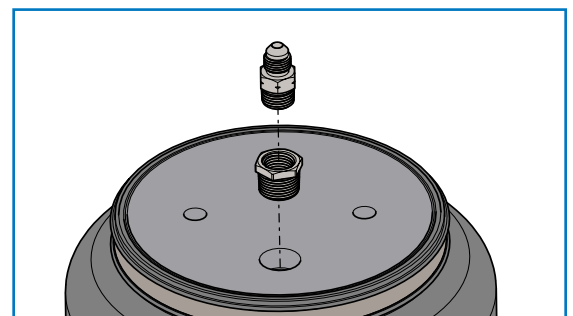

3.2

BRAIDED STAINLESS STEEL AIR LINES

This section applies to all **Stainless Upgrade Kits**.

- ⊕ *The braided stainless steel air line cannot be trimmed.*
- ! *Keep the air line away from the fuel line, brake lines and electrical wires.*

4.1 Install the air line to the air spring fittings.

Torque the braided stainless steel hose to 15 – 16 N•m [11 – 12 ft-lbs].

4.2 Use the supplied zip ties to secure the air line to fixed points along the chassis every 6" to 8" (152 to 203 mm) from the air spring to the fill location.

Leave at least 2" (51 mm) of slack to allow for any movement that might pull on the air line.

4.3 If installing the air line without an air control system:

Two fill valves are provided in this kit. The most common place to install them is in place of the license plate fasteners.

Alternatively, two 5/16" holes can be drilled in a location of your choosing.

(Using Figure 4.3 for assembly reference) Install the stainless steel Schrader valve to the end of the stainless steel braided hose.

Torqued the hose-end to 15 – 16 N•m [11 – 12 ft-lbs].

- ⊕ *It is easiest to properly torque the hose ends before the Schrader valve is secured to the vehicle body.*

Place a 5/16" hex nut and a lock washer on the air valve. Leave enough of the inflation valve in front of the nut/lock washer to extend through the vehicle body, or alternative 5/16" hole of your choosing, then complete the assembly by installing a flat washer, hex nut, and a schrader valve cap.

There should be enough valve exposed after installation – approximately 1/2" – to easily apply a pressure gauge or an air chuck.

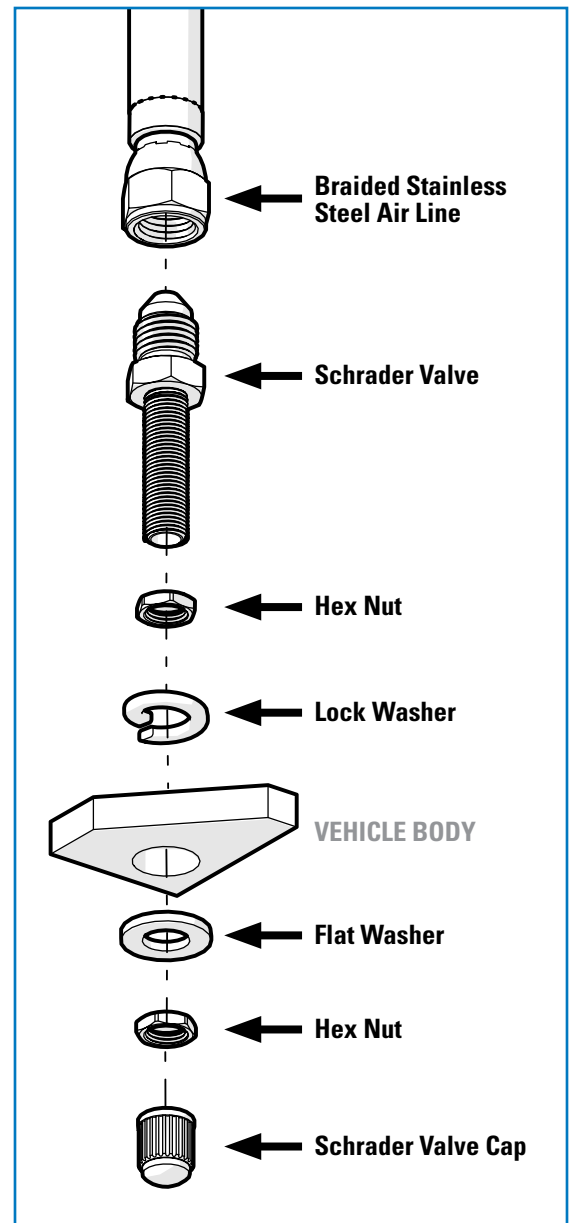

4.3

4.4 If installing the line with an air control system:

Install the stainless steel push-to-connect (PTC) fitting to the end of the stainless steel braided hose.

Torqued the hose-end to 15 – 16 N•m [11 – 12 ft-lbs].

Insert the nylon air hose, connected to the air control system, into the stainless steel PTC fitting.

Moisten the end of the nylon air line prior to inserting it into the fitting and push it in until it stops.

+ *You should feel 2 clicks which indicate a tight seal.*

4.5 Coil and secure any excess air line with the remaining zip ties, in an area where it will not be susceptible to damage.**5 CHECK SYSTEM FOR LEAKS**

Inflate both air springs to 90 psi, then use a mixture of dish soap and water on all air line connections to detect any air leaks.

Large, expanding bubbles indicate a leak (as shown in Figure 5).

Repair as necessary and retest.

Inflate air springs to a predetermined value and on following day recheck pressure.

If one or both of air springs have lost pressure, an air leak is present.

! *Leak must be repaired, and then retested until no leaks exist.*

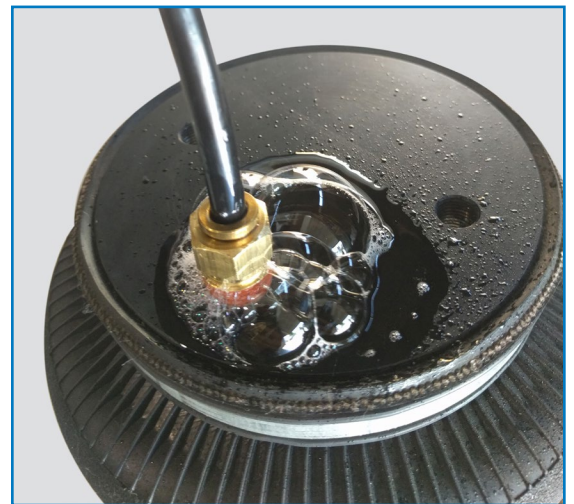

*Air Spring & NPT Air Fitting may differ between kits

B

CONGRATULATIONS! You have completed the install

After Installation continues on the following page.

Thank you again, and congratulations on the installation of your Air Suspension kit.

AFTER COMPLETING THE INSTALLATION

- The air spring must have clearance between itself and the surrounding components to prevent any contact when spring is inflated or compressed. Trimming off excess bolt length may also be required to ensure no contact with the spring or other suspension components can be made once installed.
- If removed, re-install the wheels and torque fasteners to the manufacturer’s specifications. Re-torque all fasteners after the first 500 miles of driving.

OPERATING YOUR VEHICLE WITH AIR SUSPENSION

Air springs have minimum and maximum recommended pressure requirements:

PART #	SPRING STYLE	SPRING TYPE	MIN PSI	MAX PSI
HP10189	In-Coil	STANDARD DUTY	5 PSI	70 PSI
HP10560		STANDARD DUTY		
HP10001	Sleeve Style	STANDARD DUTY	10 PSI	100 PSI
HP10173		STANDARD DUTY		
HP10199		STANDARD DUTY		
HP10083	Single Convoluted	HEAVY DUTY	5 PSI	100 PSI
HP10083J		HEAVY DUTY with JOUNCE BUMPER	0 PSI* / 5 PSI	100 PSI
HP10000	Double Convoluted	HEAVY DUTY	5 PSI	100 PSI
HP10000J		HEAVY DUTY with JOUNCE BUMPER	0 PSI* / 5 PSI	100 PSI
HP10068	Large Double Convoluted	HEAVY DUTY	5 PSI	100 PSI
HP10438	Double Convoluted	EXTREME DUTY	5 PSI	100 PSI
HP10438J		EXTREME DUTY with JOUNCE BUMPER	0 PSI* / 5 PSI	100 PSI

** Springs with a jounce bumper can be run at zero PSI when vehicle is unloaded only*

For safe and proper operation, never operate the vehicle over the maximum listed PSI in the air springs. Staying under the pressure limit will ensure maximum air spring life. **Failure in doing so may result in damage to your vehicle and/or a void warranty.**

! It is recommended to check the air pressure in your air springs daily for first couple of days to ensure a leak has not developed.

Air springs are designed to maintain the vehicle’s stock ride height with a load. Do not use the air springs as a means to lift vehicle with no load. This will result in a harsh ride.

SERVICING YOUR VEHICLE WITH AIR SUSPENSION

When lifting the vehicle with a floor jack or hoist on the frame, never allow the air spring to limit the travel of the axle. Try to always jack the vehicle on the axle. Suspending the axle with the air spring limiting the axle travel will damage the air spring and void the air spring warranty.

WARRANTY

See additional warranty included with this kit for details.