

Installation Manual



AIR SUSPENSION KIT

RAM 2500 (2WD/4WD)*⁺

** Will fit models equipped with factory 5th wheel prep packages*

** Will not fit with factory optional air equipped*

HEAVY DUTY KITS ⁺ *Requires an additional 2" Air Spring Spacer (HP10152, sold separately) on vehicles where the distance from the bottom of the jounce bumper mount to the top of the strike plate is greater than 7.5"*

XTREME DUTY KITS ⁺ *Will not fit on vehicles where the distance from the bottom of the jounce bumper mount to the top of the strike plate is greater than 7.5"*

Use the most advanced air springs on the market to eliminate your vehicle's sag, sway and bottoming out. This heavy duty air suspension kit levels your truck's stance while providing added support for an overall smooth and safe ride.

Please read the entire manual prior to starting the installation to ensure you can complete it once started. If you are unsure whether you are qualified to install the Air Suspension kit, consult a qualified service professional before beginning the installation.

SAFETY WARNINGS!

You must read and abide by the instructions found in this manual, paying close attention to the helpful (+), cautionary (!) or dangerous (!) warning icons highlighting important safety recommendations and maintenance suggestions throughout this manual. **Failure to abide by all instructions in this manual will void the warranty.**

HELPFUL INSTALL TIP
Additional information that could potentially make the job a little easier.

PLEASE USE CAUTION
Unsafe practices could result in damage to you or your vehicle, or others.

DANGER WARNING
Hazards which could result in severe personal injury or death.

- ! **Serious personal injury or death may result from an air spring failure** or accident due to improper installation or air spring pressure operation or maintenance.
- ! **Inflating an unsecured air spring is dangerous.** If it bursts, it could be hurled into the air with explosive force resulting in serious personal injury or death. Never inflate an air spring unless it is secured to the vehicle.
- ! **Removing and replacing air springs can be dangerous.** This is only a job for a qualified service professional. Never perform air spring service procedures without proper training, tools, and equipment.
- ! An air suspension kit will not increase the GVWR (Gross Vehicle Weight Rating), as the GVWR is determined by the vehicle manufacturer. **Do not exceed the maximum capacity listed by the vehicle manufacturer.**

- ! For safe and proper operation of the vehicle, never operate the vehicle under the minimum or over the maximum listed PSI in the air spring(s), (see: *MIN/MAX PSI* chart on the final page of this manual). Staying within the pressure limits will ensure a reasonable duration of the air springs. **Failure in doing so may result in damage to your vehicle and will void the warranty.**

BEFORE STARTING THE INSTALLATION

- ! **Always read your vehicle owner's manual and follow all instructions and warnings therein prior to modifying your vehicle.**
- ! Ensure the application information is correct for the make, model and year of the vehicle you are installing the kit on.
 - ! **PLEASE BE AWARE:**
5000lb HD kits being installed on vehicles where the distance from the bottom of the jounce bumper mount to the top of the strike plate is greater than 7.5" require an additional 2" Air Spring Spacer (HP10152, sold separately). [See Page 6 for details].
7500lb XD kits will not fit on vehicles where the distance from the bottom of the jounce bumper mount to the top of the strike plate is greater than 7.5". [See Page 6 for details].
- ! It is recommended to always jack the vehicle on the axle. If lifting the vehicle with a floor jack or hoist on the frame, never allow the air spring to limit the travel of the axle. Suspending the axle with the air spring limiting the axle travel **will damage the air spring and void the warranty.** (This warning does not apply to In-Coil Springs)
- ! The air spring must have clearance between itself and the surrounding components to prevent any contact when the air spring is inflated or compressed. Trimming off excess bolt length may also be required to ensure no contact with the spring or other suspension components can be made once installed. **Failure to do so will void the warranty.**
- ! Some vehicles are equipped with a rear wheel brake proportioning valve. Check with the manufacturer before installing the air spring kit, as it may affect braking performance.
- ! This kit contains push-to-connect fittings; using scissors or wire cutters to cut the nylon air line will distort the line and cause the connection to leak. The air line must be cut off squarely with the hose cutter provided in this kit, or a sharp utility knife. **Failure to do so will void the warranty.**
- + It is recommended to use additional thread sealant or Teflon tape on fittings during the installation for a proper seal.
- ! Always ensure the bolts are not over-torqued; especially when a torque value is provided, failing to use the provided torque value(s) can lead to **premature failure and will void the warranty.**
- + It is recommended to use a good quality anti-seize on all fasteners to reduce the chance of corrosion and help facilitate removal, if required at a later date.

HEAVY DUTY (HD) 5000lb KIT CONTENTS

Please confirm the items below are provided in your kit before starting the installation.

XD Kit Contents are on the following page

| HEAVY DUTY KITS | | QTY | PART # |
|----------------------|-------------------------|-----|---------|
| A¹ | Double Convolved Spring | 2 | HP10000 |

| HEAVY DUTY JOUNCE BUMPER KITS | | QTY | PART # |
|-------------------------------|--|-----|----------|
| B¹ | Double Convolved Spring w/ Jounce Bumper | 2 | HP10000J |

.....

| SHARED KIT CONTENTS | | QTY | PART # |
|----------------------|------------------------------------|-----|---------|
| C¹ | Roll Plate, 4.5" Diameter | 4 | HP10054 |
| D¹ | Fitting, 1/4" NPT | 2 | HP1099 |
| E | Bracket, Frame | 2 | HP1411 |
| F | Bracket, Upper | 2 | HP1412 |
| G¹ | Bracket, Lower | 2 | HP1413 |
| H | Axle Strap | 2 | HP1383 |
| I | Bolt, 3/8" - 16 x 1.25" Hex Head | 2 | C10464 |
| J | Bolt, 3/8" - 16 x 1.25" Carriage | 4 | HP1149 |
| K | Bolt, 3/8" - 24 x 3/4" Carriage | 4 | HP1977 |
| L | Bolt, 3/8" - 16 x 10" Carriage | 4 | HP1329 |
| M | Bolt, M10 x 1.5 x 35mm Button Head | 4 | HP1414 |
| N | Washer, 3/8" Flat | 8 | C653 |
| O | Washer, 1/2" x 2" OD Thick Flat | 2 | HP1369 |
| P | Nut, 3/8" Nylon Lock | 10 | HP1000 |
| Q | Heat Shield | 1 | HP0012 |
| R | Worm Gear Ring Clamp | 2 | HP1001 |
| S | Bolt 3/8" - 24 x 3/4" Countersunk | 4 | HP1008 |

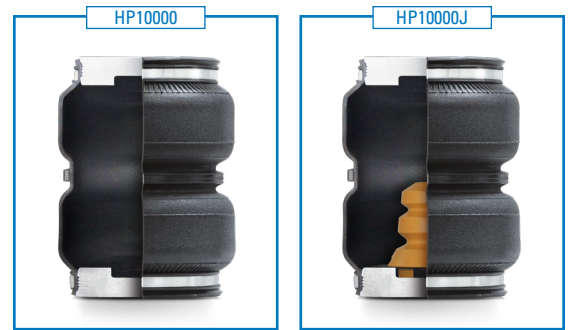

REQUIRED TOOLS

- Hoist or Floor Jack
- Safety Glasses
- Pipe Thread Sealant
- Standard Combination Wrenches
- 7/32" Hex Allen Wrench
- Metric & Standard Sockets
- Hose Cutter (included) or Sharp Utility Knife
- Spray Bottle with Dish Soap/Water
- Air Compressor/Compressed Air Source (to test/fill air springs)
- Heavy Duty Drill
- 3/8 & 5/16 drill bits (very sharp)
- 3/8 Nut Driver
- Safety Stands
- Torque Wrench
- Ratchet



WARNING: This product can expose you to the chemical Hexavalent Chromate, which is known to the State of California to cause cancer and birth defects or other reproductive harm. *For more information go to www.P65Warnings.ca.gov*

XTREME DUTY (XD) 7500lb KIT CONTENTS

Please confirm the items below are provided in your kit before starting the installation.

HD Kit Contents are on the previous page

| XTREME DUTY KITS | | QTY | PART # |
|------------------|--------------------------|-----|---------|
| A ² | Double Convoluted Spring | 2 | HP10438 |

| XTREME DUTY JOUNCE BUMPER KITS | | QTY | PART # |
|--------------------------------|---|-----|----------|
| B ² | Double Convoluted Spring w/ Jounce Bumper | 2 | HP10438J |

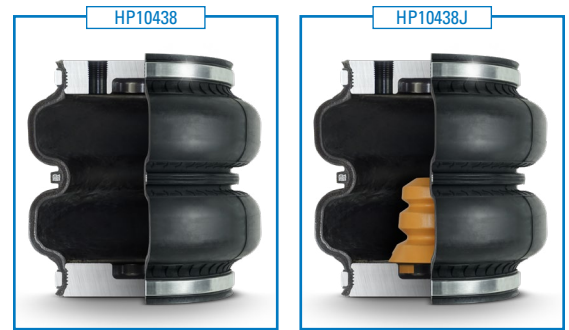

| SHARED KIT CONTENTS | | QTY | PART # |
|---------------------|------------------------------------|-----|---------|
| C ² | Roll Plate, 5.5" Diameter | 4 | HP10069 |
| D ² | Fitting, 3/8" NPT | 2 | HP1385 |
| E | Bracket, Frame | 2 | HP1411 |
| F | Bracket, Upper | 2 | HP1412 |
| G ² | Bracket, Lower | 2 | HP1652 |
| H | Axle Strap | 2 | HP1383 |
| I | Bolt, 3/8" - 16 x 1.25" Hex Head | 2 | C10464 |
| J | Bolt, 3/8" - 16 x 1.25" Carriage | 4 | HP1149 |
| K | Bolt, 3/8" - 24 x 3/4" Carriage | 8 | HP1977 |
| L | Bolt, 3/8" - 16 x 10" Carriage | 4 | HP1329 |
| M | Bolt, M10 x 1.5 x 35mm Button Head | 4 | HP1414 |
| N | Washer, 3/8" Flat | 8 | C653 |
| O | Washer, 1/2" x 2" OD Thick Flat | 2 | HP1369 |
| P | Nut, 3/8" Nylon Lock | 10 | HP1000 |
| Q | Heat Shield | 1 | HP0012 |
| R | Worm Gear Ring Clamp | 2 | HP1001 |

RECOMMENDED TOOLS

- Hoist or Floor Jack
- Safety Glasses
- Pipe Thread Sealant
- Standard Combination Wrenches
- 7/32" Hex Allen Wrench
- Metric & Standard Sockets
- Hose Cutter (included) or Sharp Utility Knife
- Spray Bottle with Dish Soap/Water
- Air Compressor/Compressed Air Source (to test/fill air springs)
- Heavy Duty Drill
- 3/8 & 5/16 drill bits (very sharp)
- 3/8 Nut Driver
- Safety Stands
- Torque Wrench
- Ratchet



WARNING: This product can expose you to the chemical Hexavalent Chromate, which is known to the State of California to cause cancer and birth defects or other reproductive harm. For more information go to www.P65Warnings.ca.gov

KIT EXPLOSION DIAGRAM

DRIVER SIDE ASSEMBLY SHOWN (Passenger side assembly is mirrored)

See **Requirement for Spacer** note on following page

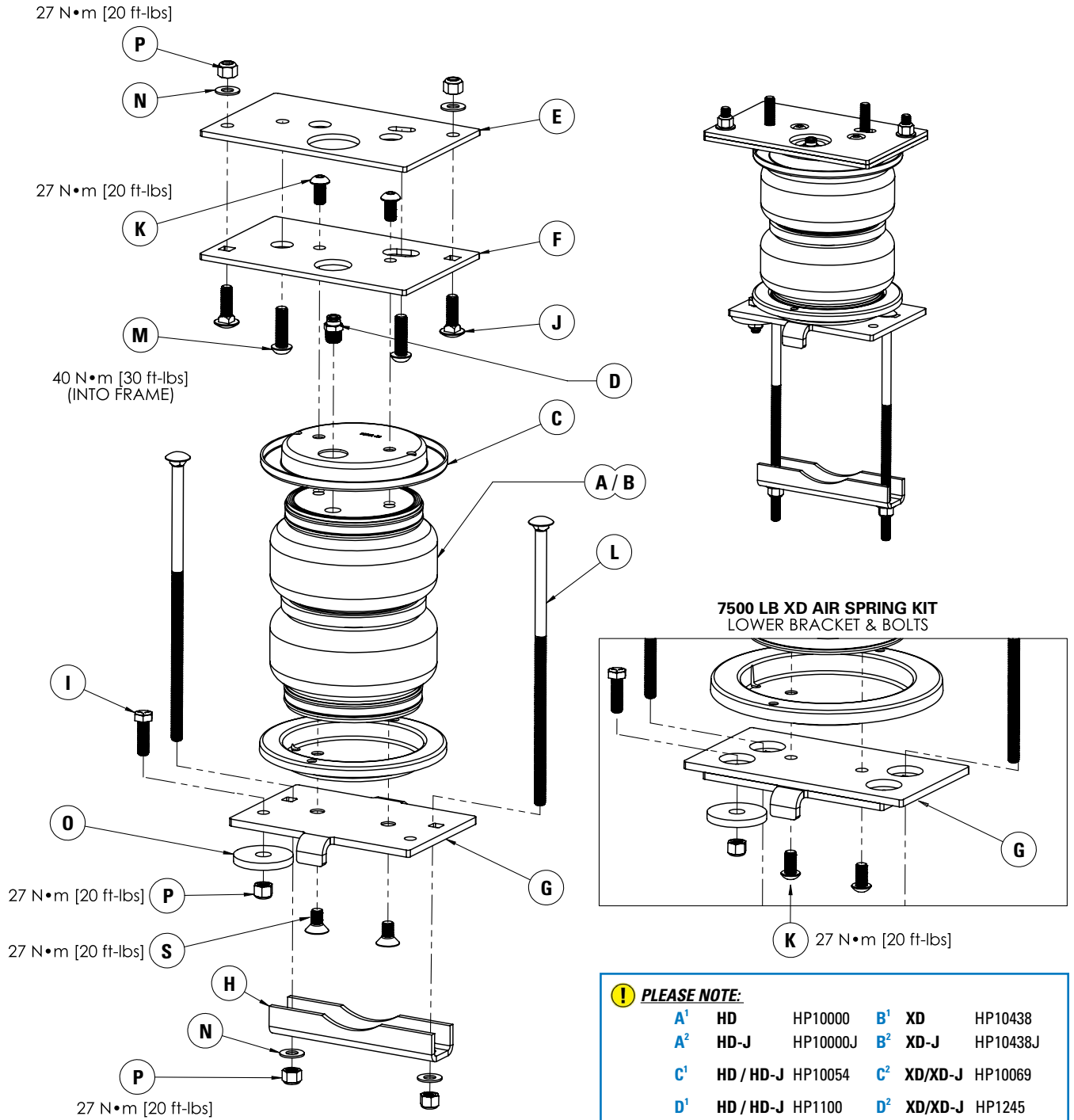

REQUIREMENTS FOR A 2" SPACER

! HEAVY DUTY (HD) 5000lb Air Spring Kits

A 2" Spacer (HP10152) is required for all vehicle models compatible with this Heavy Duty Air Suspension kit where the distance between the bottom of the jounce bumper mount to the top of the strike plate (see A in Figure 1 below) is greater than 7.50".

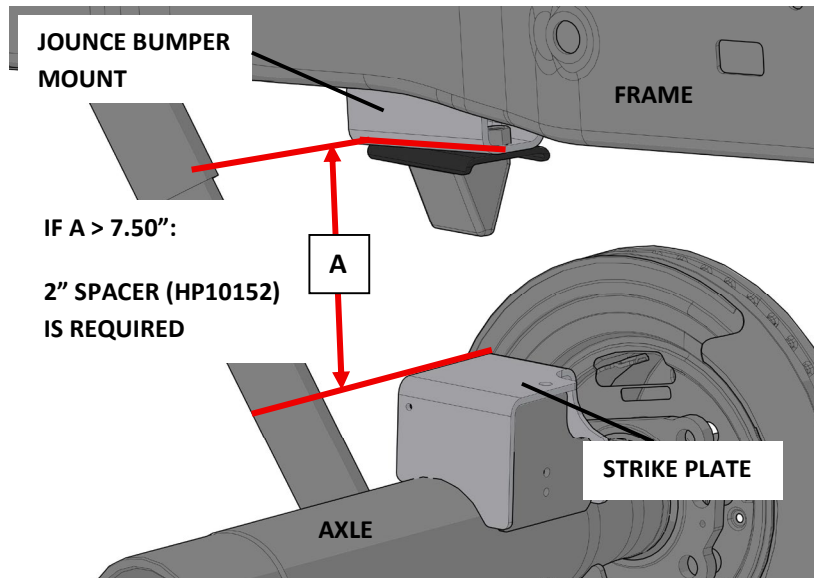

Figure 1. Diagram of RAM 2500 Rear Suspension

AIR SPRING (HP10000) HEIGHTS – IN HP10206

See the table below for estimates of installed air spring (HP10000) heights in an HP10206 kit.

| Distance from Frame to Strike Plate* | | Expected Approximate Installed Spring (HP10000) Heights** | |
|---|--------------|---|----------------------------|
| | | Without a 2" Spacer (HP10152) | With a 2" Spacer (HP10152) |
| <i>Estimated</i> Height of Power Wagon Models | 8.0" – 8.75" | 7.25" – 8.0" | 5.25" – 6.0" |
| <i>Estimated</i> Height of Non-Power Wagon Models | 6.0" – 6.75" | 5.25" – 6.0" | 3.25" – 4.0" |

*Distance from frame to strike plate measured prior to spring installation

** Springs installed in an unloaded vehicle on level ground with air springs inflated to 10 PSI.

| Data on HP10000 Air Spring | |
|------------------------------|-----------------|
| Minimum Operating Bag Height | 3.0" [76.2 mm] |
| Maximum Operating Bag Height | 8.4" [213.4 mm] |

! XTREME DUTY (XD) 7500lb Air Spring Kits

This kit will not fit on vehicles where the distance from the bottom of the jounce bumper mount to the top of the strike plate is greater than 7.5".

HP10438 / HP10438J Xtreme Duty Air Springs are not compatible with Air Spring Spacers.

INSTALLATION INSTRUCTIONS

1 MEASURE STOCK RIDE HEIGHT & CLEARANCE

Park the vehicle on a level surface and remove any unnecessary weight from the vehicle to attain a "Normal Ride Height".

Using a measuring tape, measure the distance between the center of the wheel hub and the bottom of the fender well (see Figure 1A for reference) this will give you your stock Normal Ride Height.

Note the ride height for all four tires.

Check the clearance between the outside of the frame and the inside of the rear tires (as shown in red in Figure 1B), a minimum of 5" is required for adequate air spring clearance.

2 REMOVE REAR WHEELS

+ PLEASE NOTE: This step is optional for this installation but will make the install easier to complete.

Place wheel chocks in front of and behind both front wheels.

Raise the rear of the truck high enough to remove both wheels and attain a comfortable working height.

Place two jack stands under rear axle (as shown in Figure 1B).

Lower the vehicle until the axle is supported by the jack stands.

Remove rear wheels.

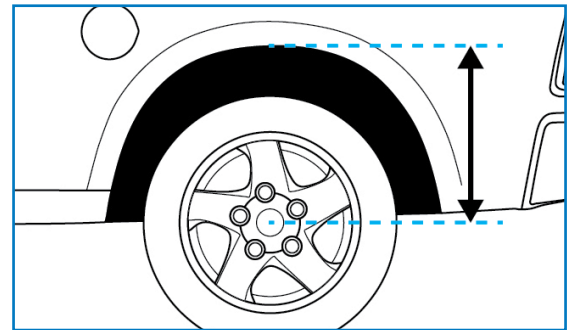

1A

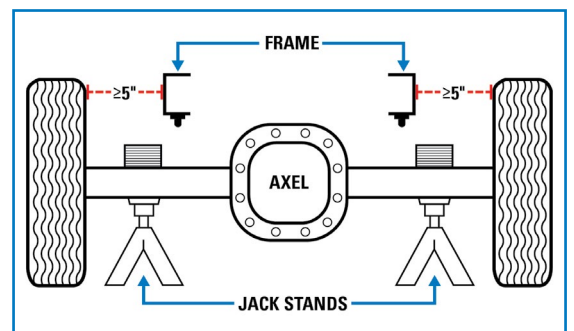

1B

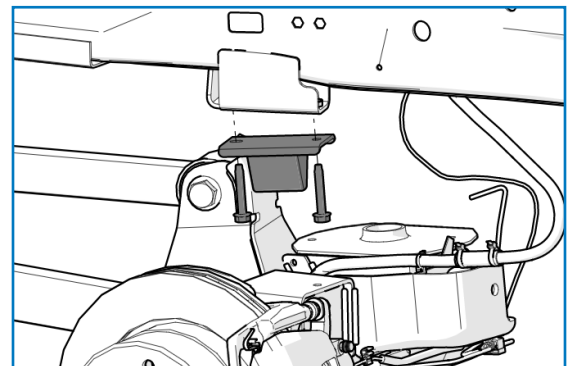

3

3 REMOVE JOUNCE BUMPER

Remove the two bolts securing jounce bumper to frame rail on both sides of the vehicle.

Discard the hardware as it will not be reused in this installation.

4 ZIP TIE VENT TUBE (IF EQUIPPED)

Some models may have a small vent tube extending from the axle near the bump stop on the driver's side of the vehicle.

If equipped, zip tie the vent tube to the small hole on the spring mount (as shown in Figure 4).

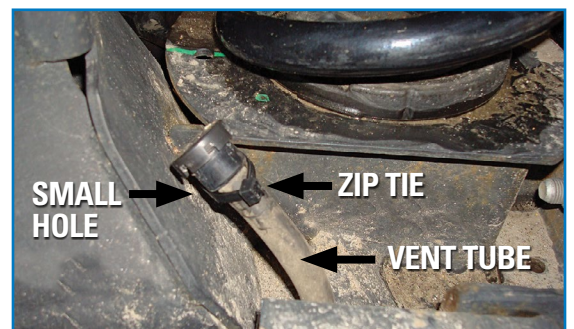

4

5 INSTALL AIR FITTINGS

Set a roll plate over the top surface of each air spring (as shown in Figure 5).

Insert the air fitting into the large threaded hole and tighten finger tight plus an additional 1.5 turns.

+ *The use of thread sealant or Teflon tape is recommended.*

6 ATTACH UPPER AIR SPRING PLATES

Insert two 3/8" – 16 x 1.25" carriage bolts through the square holes in the upper air spring plate and set the plate on the air spring (as shown in Figure 6).

! *Take note of the orientations of the plates as the kit cannot be installed if they are placed incorrectly.*

+ *Carriage bolts must be inserted before bolting plate to the air spring as the roll plate may prevent insertion of the bolts when plate is tightened.*

Secure the plate to the air spring using two 3/8" – 24 x 3/4" bolts.

Torque to 27 N•m (20 ft-lbs).

7 PREPARE LOWER BRACKETS

Install the 1/2" x 2" OD thick flat washer on the underside of the lower bracket using a 3/8" – 16 x 1.25" bolt and 3/8" nylon lock nut.

! *Note the installation hole location in Figure 7 as each hole corresponds to a certain vehicle side.*

Torque the bolt to 27 N•m (20 ft-lbs).

Insert two 3/8" – 16 x 10" carriage bolts as shown through the square holes in the lower bracket.

+ *Carriage bolts must be inserted before attaching the lower bracket to the air spring as the roll plate will cover the carriage bolt holes.*

! *For vehicles where the distance from the bottom of the jounce bumper mount to the top of the strike plate is greater than 7.5"; you will need to install the additional 2" Air Suspension Spacer kit (Part# HP10152) now, as per the manual included in that kit. (See note on Page 6)*

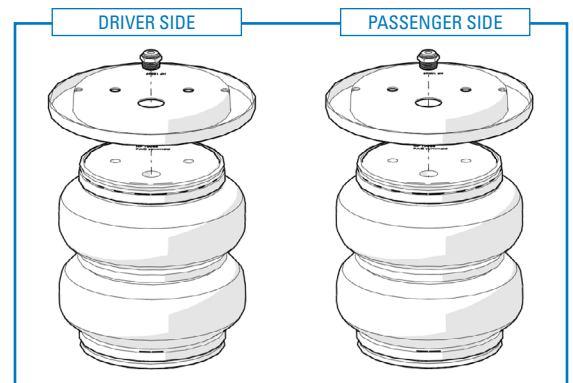

5

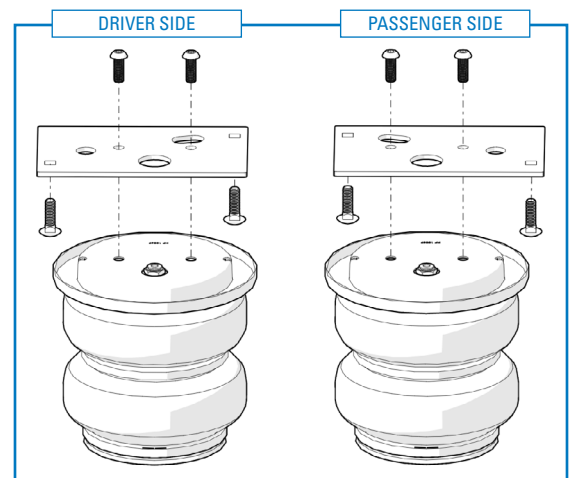

6

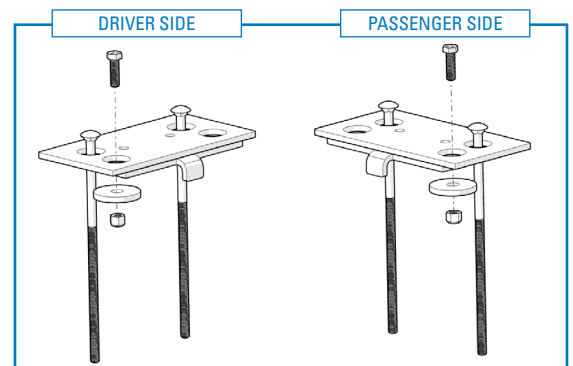

7

8 ATTACH LOWER BRACKETS TO AIR SPRINGS

Set a roll plate on the bottom surface of the air spring.

Place the driver side lower bracket assembly on the driver side air spring assembly and align the holes in the air spring, roll plate and lower bracket.

! *The large thick washer (circled in Figure 8) must be on the same side as the air fitting on the top of the spring.*

Secure bracket with two 3/8" – 24 x 3/4" bolts and torque to 27 N•m (20 ft-lbs).

Repeat process for passenger side spring assembly.

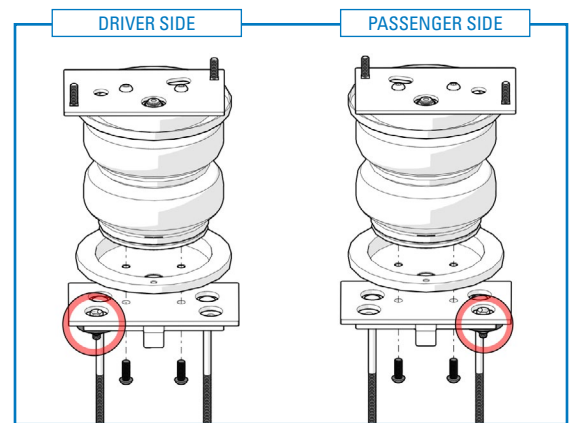

8

9 INSTALL UPPER FRAME BRACKET

Attach the upper frame bracket to the frame of the vehicle by installing two M10 button head screws through the bracket into the holes previously occupied by the jounce bumper hardware (removed in Step 3).

! *Refer to Figures 9A and 9B for the correct plate orientation.*

The large round hole must face outwards towards the tire and bolt in the slotted hole must be attached to the rearward jounce bumper hole.

Torque the button head screws to 40 N•m (30 ft-lbs).

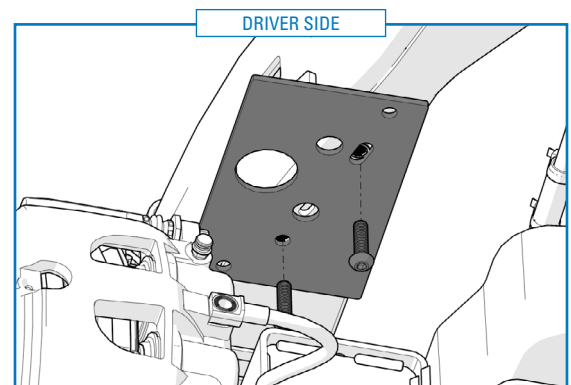

9A

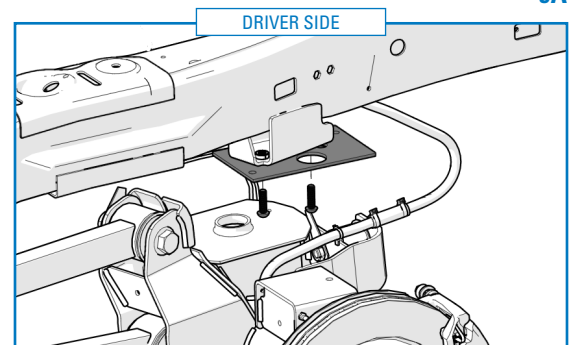

9B

10 INSTALL AIR SPRING ASSEMBLIES

+ *It may be necessary to raise the frame of the truck a few inches to allow more clearance to install the spring assemblies*

Set the driver side spring assembly in place (as shown in Figure 10A).

Ensure the rear carriage bolt sits between the axle and the brake lines (see circled area in Figure 10B on the following page for reference).

Fasten the spring assembly to the upper frame bracket by inserting the pre-installed carriage bolts through the round holes in the frame bracket and secure with two 3/8" flat washers and two 3/8" nylon lock nuts.

Torque lock nuts to 27 N•m (20 ft-lbs).

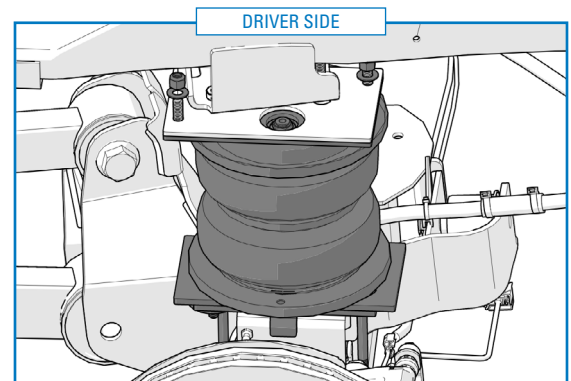

10A

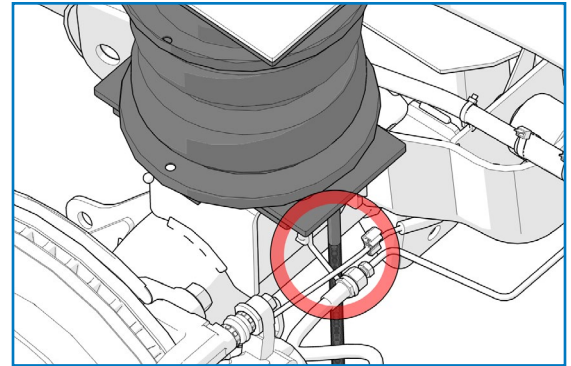

10B

11 SECURE LOWER BRACKET

Raise the axle or lower the frame so the lower bracket sits flat on the jounce bumper strike plate.

Adjust the bracket so the large flat washer is touching the side of the strike plate (see circled area in Figure 11A for reference).

! *Make sure the air spring is correctly aligned vertical as per Figure 11B.*

Place the axle strap on the two carriage bolts (see Figure 11A) and secure with two 3/8" flat washers and two 3/8" nylon lock nuts.

Torque the lock nuts to 27 N•m (20 ft-lbs).

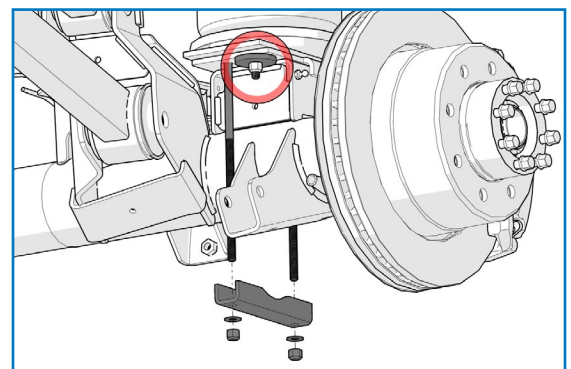

11A

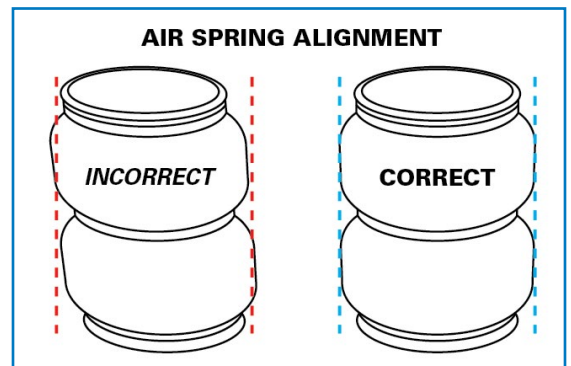

11B

12 INSTALL HEAT SHIELD

Bend tabs on the heat shield so the required 1/2" of dead space exists between the heat shield and exhaust when attached.

Attach the heat shield to the exhaust pipe on the passenger side using two ring clamps (shown in Figure 12). Each hose clamp holds a tab against exhaust pipe.

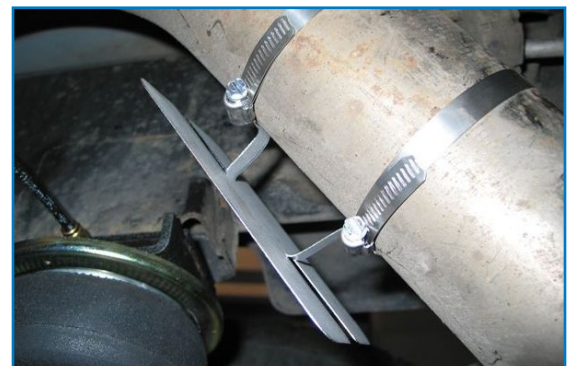

12

INSTALL AIR LINE

Two fill valves are provided in this kit. The most common place to install them is in place of the license plate fasteners. Alternatively, two 5/16" holes can be drilled in a location of your choosing.

Cut the air line assembly into two equal lengths with the hose cutter provided in this kit or a sharp utility knife.

! **PLEASE NOTE:** This kit contains push-to-connect fittings; using scissors or wire cutters to cut the nylon air line will distort the line and cause the connection to leak. The air line must be cut off squarely with a hose cutter or a sharp utility knife.

Install one air line at a time starting at the fill valve location. Place a 5/16" nut on the air valve. Leave enough of the inflation valve in front of the nut to extend through the hole, install a flat washer, and 5/16" nut and cap (reference Figure A for assembly). There should be enough valve exposed after installation – approximately 1/2" – to easily apply a pressure gauge or an air chuck.

Route the air line back to the NPT fitting on the air spring, then cut the hose to length. Moisten the end of the air line prior to inserting it into the fitting and push it in until it stops.

Repeat with the other fill valve.

Secure the air lines using the provided tie-straps, away from any moving items and heat sources.

CHECK SYSTEM FOR LEAKS

Using the *MIN/MAX PSI* chart on the following page; inflate both air springs to 10 psi less than the maximum recommended pressure for the air spring part number included in this kit; then use a mixture of dish soap and water on all air line connections to detect any air leaks. Large, expanding bubbles indicate a leak (as shown in Figure B).

! **Leak must be repaired, and then retested until no leaks exist.**

Recheck the pressure on the following day. If one or both of air springs have lost pressure, an air leak is present and must be repaired.

CONGRATULATIONS! You have completed the install

After Installation continues on the following page.

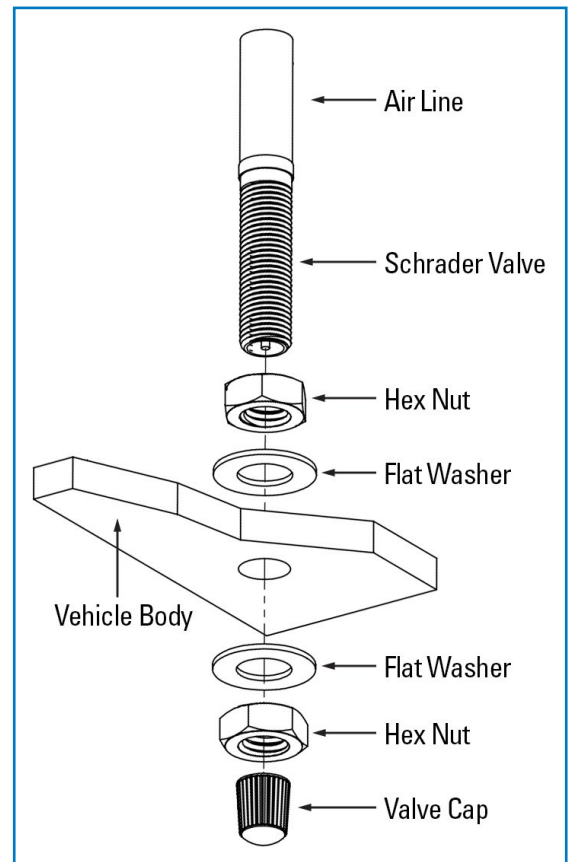

A

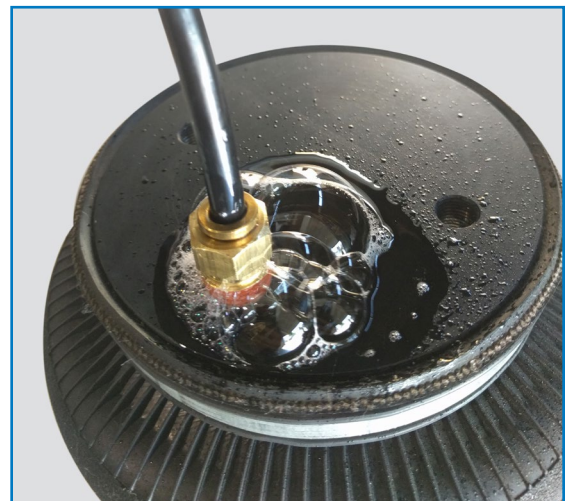

*Air Spring & NPT Air Fitting may differ between kits

B

Thank you again, and congratulations on the installation of your Air Suspension kit.

AFTER COMPLETING THE INSTALLATION

- ! The air spring must have clearance between itself and the surrounding components to prevent any contact when the air spring is inflated or compressed. Trimming off excess bolt length may also be required to ensure no contact with the spring or other suspension components can be made once installed. **Failure to do so will void the warranty.**
- ! If the vehicle’s tires were removed during the installation; re-install and torque all wheel fasteners (lug nuts) to the manufacturer’s specifications. Re-torque all wheel fasteners after the first 500 miles of driving.
- ! **Review your vehicle owner’s manual and adhere to all instructions and post-installation requirements related to vehicle modifications.**

OPERATING YOUR VEHICLE WITH AIR SUSPENSION

Air springs have minimum and maximum recommended pressure requirements:

| MIN / MAX PSI: REQUIREMENTS FOR YOUR AIR SPRING(S) | | | | |
|--|-------------------------|---------------------------------|----------------|---------|
| PART # | SPRING STYLE | SPRING TYPE | MIN PSI | MAX PSI |
| HP10687 | In-Coil | STANDARD DUTY | 5 PSI | 50 PSI |
| HP10560 | | STANDARD DUTY | 5 PSI | 70 PSI |
| HP10001 | Sleeve Style | STANDARD DUTY | 10 PSI | 100 PSI |
| HP10173 | | STANDARD DUTY | | |
| HP10199 | | STANDARD DUTY | | |
| HP10083 | Single Convoluted | HEAVY DUTY | 5 PSI | 100 PSI |
| HP10083J | | HEAVY DUTY with JOUNCE BUMPER | 0 PSI* / 5 PSI | 100 PSI |
| HP10000 | Double Convoluted | HEAVY DUTY | 5 PSI | 100 PSI |
| HP10000J | | HEAVY DUTY with JOUNCE BUMPER | 0 PSI* / 5 PSI | 100 PSI |
| HP10068 | Large Double Convoluted | HEAVY DUTY | 5 PSI | 100 PSI |
| HP10438 | Double Convoluted | EXTREME DUTY | 5 PSI | 100 PSI |
| HP10438J | | EXTREME DUTY with JOUNCE BUMPER | 0 PSI* / 5 PSI | 100 PSI |

** Springs with a jounce bumper can be run at zero PSI when vehicle is unloaded only*

Never operate the vehicle under the minimum or over the maximum listed PSI in the air spring(s). Staying within the pressure limits will ensure maximum air spring life. **Failure in doing so may result in damage to your vehicle and void the warranty.**

- ! **It is recommended to check the air pressure in your air springs daily, for the first 5 days, to ensure a leak has not developed.**

Air springs are designed to maintain the vehicle’s stock ride height with a load. Do not use the air springs as a means to lift vehicle with no load. This will result in a harsh ride.

SERVICING YOUR VEHICLE WITH AIR SUSPENSION

It is recommended to always jack the vehicle on the axle. If lifting the vehicle with a floor jack or hoist on the frame, never allow the air spring to limit the travel of the axle. Suspending the axle with the air spring limiting the axle travel **will damage the air spring and void the warranty.** (This warning does not apply to In-Coil Springs)

WARRANTY

See accompanying limited warranty included with this kit for details.