

# Installation Manual

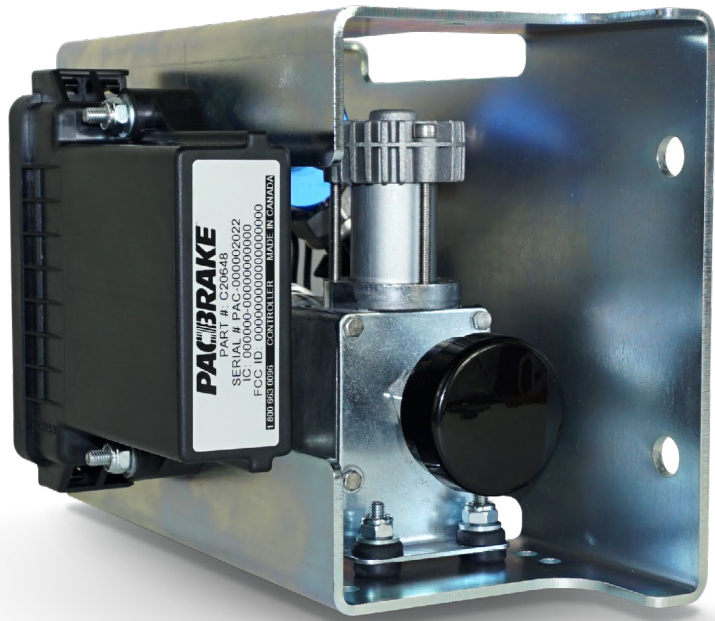

## QUICK MOUNT SINGLE CHANNEL WIRELESS AIR SPRING CONTROLS

- 10470-QM** Kit w/ 12 VDC 325 Series Air Compressor
- 10472-QM** Kit w/ 12 VDC 90 Series Air Compressor

*Giving you the ability to adjust your air spring pressure from your phone with the touch of a button. It's the perfect means to control your vehicle's air suspension system from inside or outside your vehicle!*

**Thank you & congratulations on the purchase of a Quick Mount Single Channel Wireless Air Spring Control Kit.**

KIT PART #	KIT DESCRIPTION
<b>10470-QM</b>	Single Channel Wireless Air Spring Control Kit w/ 12 VDC <b>325 Series Air Compressor</b>
<b>10472-QM</b>	Single Channel Wireless Air Spring Control Kit w/ 12 VDC <b>90 Series Air Compressor</b>

**KIT CONTENTS**

*Please make sure all the items listed below are provided in your kit before starting the installation.*

KIT CONTENTS	QTY	PART #	REQUIRED TOOLS
<b>A Mounted Assembly, Wireless Compressor:</b>			<ul style="list-style-type: none"> <li>• Wire Strippers</li> <li>• Terminal Crimper</li> <li>• Heat Gun or Torch</li> <li>• Ratchet and Socket Set</li> <li>• Multi Meter or Test Light</li> <li>• Torque Wrench</li> <li>• Tube Cutter or Sharp Utility Knife</li> </ul>
• 90 Series Compressor (10472-QM)	1	HP10574	
• 325 Series Compressor (10470-QM)	1	HP10576	
<b>B</b> Harness, Single Channel Wireless	1	HP10454	
<b>C</b> U-Bolt, 3/8 - 16 x 5.5" x 9.5" Square	2	HP1511	
<b>D</b> Screw, #10 X 3/4" Self Tapping	1	P60100	
<b>E</b> Screw, #10-32 X 3/4" Socket Head	1	HP1209	
<b>F</b> Washer, #10 Flat	2	C10406	
<b>G</b> Washer, 3/8" Flat	4	C18006	
<b>H</b> Nut, #10-32 Nylon Lock	1	C10843	
<b>I</b> Nut, 3/8" Nylon Lock	4	HP1000	
<b>J</b> Fitting, Tee, 1/4" OD Tube	1	HP1176	
<b>K</b> Nylon Tube, 1/4" OD, Black	240"	M8280	
<b>L</b> Fuse Holder, 15 Amp Max	1	M6083	
<b>M</b> Fuse Holder, 30 Amp Max	1	M8170	
<b>N</b> Fuse, 10 Amp	1	M8172	
<b>O Fuse, Air Compressor</b>			
• 20 Amp (10472-QM)	1	M8171	
• 30 Amp (10470-QM)	1	M8180	
<b>P</b> Terminal, Blade, 14-16 AWG	1	M8115	
<b>Q</b> Terminal, Ring, 3/8", 10-12 AWG	2	M8262	
<b>R</b> Connector, Butt, 10-12 AWG	1	M8159	
<b>S</b> Connector, Butt, 14-16 AWG	1	M8028	
<b>T</b> T-Tap, 14-16 AWG	1	M8108	
<b>U</b> Tie Strap	16	C11618	
<b>Only included w/ HP325 compressors featuring remote air filters:</b>			
<b>V</b> Inlet Air Filter	1	C241	
<b>W</b> Nylon Tube, 1/4" OD, Blue	24"	M8685	

## KIT DIAGRAM: 10472-QM

Please make sure all the items shown in the kit contents on Page 2 are provided in your kit before starting the installation.

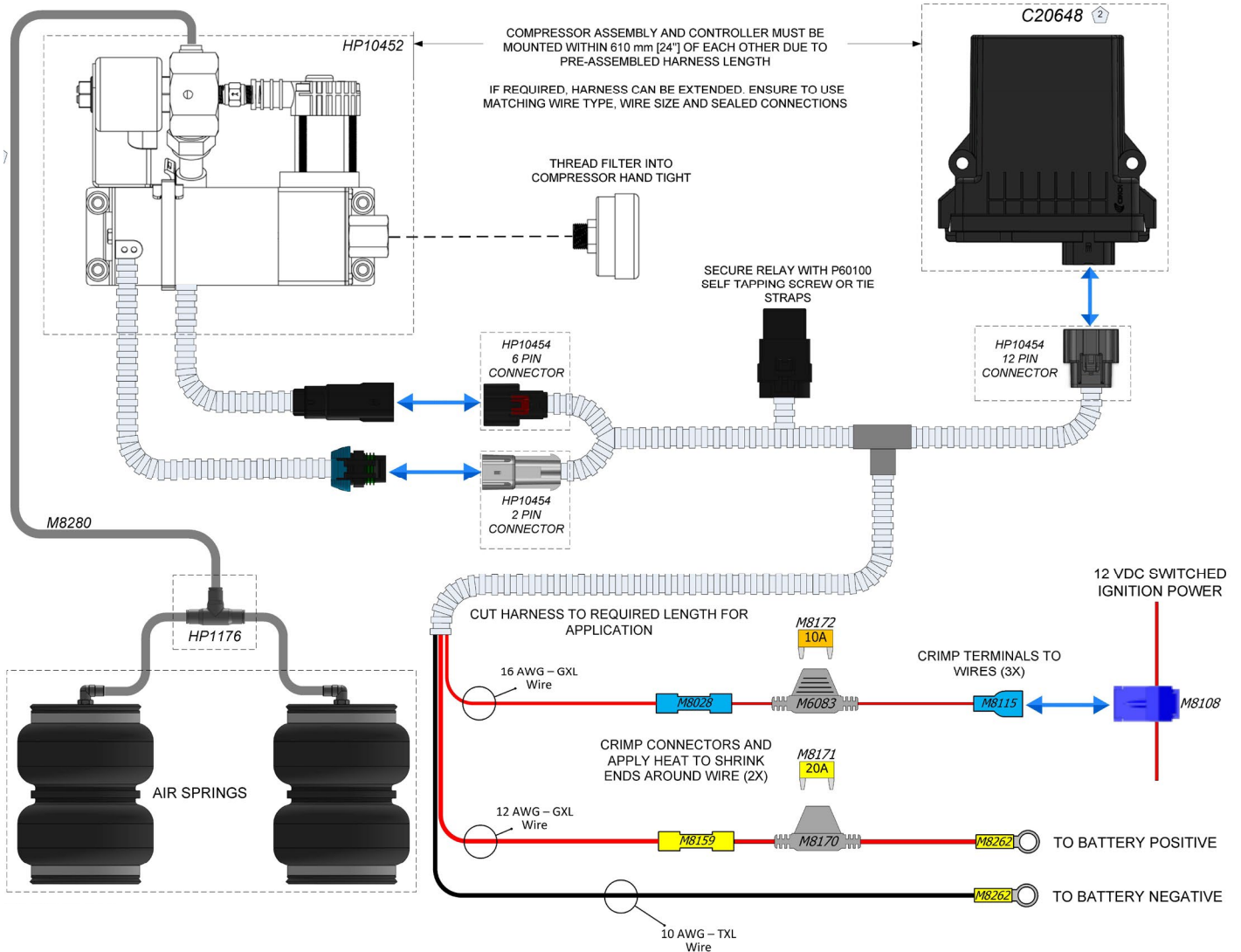

PERFORMANCE CHARACTERISTICS	
MAXIMUM WORKING PRESSURE	827.4 kPa [120 psi]
MAXIMUM DUTY CYCLE	9% @ 689.5 kPa [100 psi]
MAXIMUM CONTINUOUS RUN TIME	5 Minutes ON / 55 Minutes OFF
MAXIMUM RATED FLOW	29 LPM [1.02 CFM]
AMBIENT TEMPERATURE RANGE	-40°C to +70°C [-40°F TO +158°F]
OPERATING VOLTAGE	12 VDC
MAXIMUM CURRENT DRAW	11 Amp
INGRESS PROTECTION	IP54 Compressor Assembly IP67 Controller and Electrical Connectors
VIBRATION	8 Grms

## KIT DIAGRAM: 10470-QM

Please make sure all the items shown in the kit contents on Page 2 are provided in your kit before starting the installation.

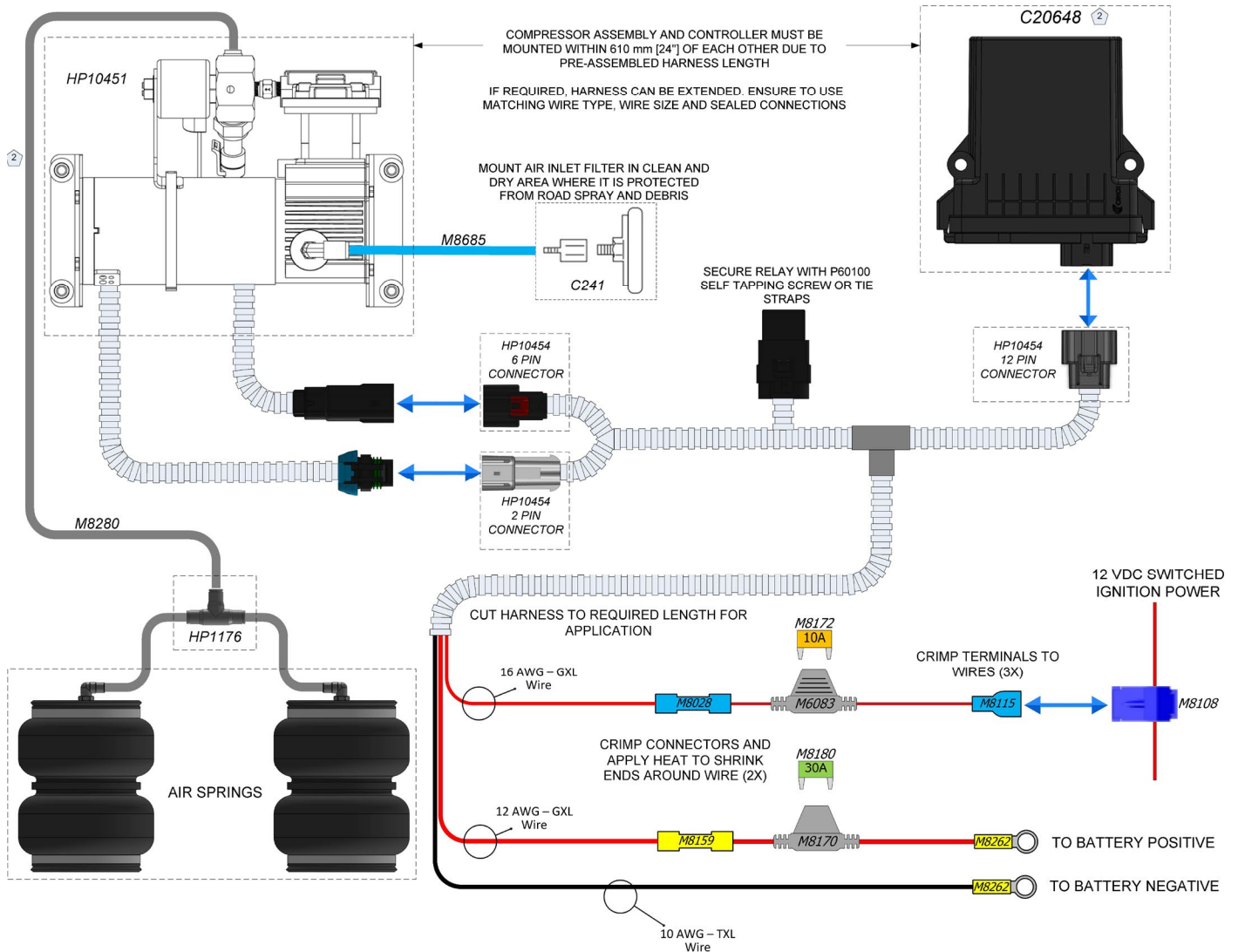

PERFORMANCE CHARACTERISTICS	
MAXIMUM WORKING PRESSURE	1034 kPa [150 psi]
MAXIMUM DUTY CYCLE	33% @ 689.5 kPa [100 psi]
MAXIMUM CONTINUOUS RUN TIME	20 Minutes ON / 40 Minutes OFF
MAXIMUM RATED FLOW	31.1 LPM [1.10 CFM]
AMBIENT TEMPERATURE RANGE	-40°C to +70°C [-40°F TO +158°F]
OPERATING VOLTAGE	12 VDC
MAXIMUM CURRENT DRAW	17 Amp
INGRESS PROTECTION	IP54 Compressor Assembly IP67 Controller and Electrical Connectors
VIBRATION	8 Grms

*This manual is used across multiple kits - please pay close attention to important warnings listed below for a safe installation.*

## BEFORE STARTING THE INSTALLATION:

1. Read through this manual and ensure you can complete the installation once started.
2. Ensure the kit you received contains all the items shown in the Kit Contents on Page 2.
3. It is recommended to use a good quality anti-seize on all fasteners. This will reduce the chance of corrosion on the fasteners and will help facilitate removal, if required at a later date.

### PLEASE NOTE:

*Using scissors or wire cutters to cut the nylon airline will distort the line and cause the connection to leak. THE AIRLINE MUST BE CUT OFF SQUARELY WITH THE NYLON HOSE CUTTER OR A SHARP UTILITY KNIFE.*

.....

## 1 INSTALL CRANKCASE MOUNTED FILTER

**For HP90 Series compressors with crankcase mounted filters ONLY:**

- Thread the included air filter into the threaded port in the front of the air compressor until hand tight

**⚠ Do NOT overtighten as the filter housing will break**

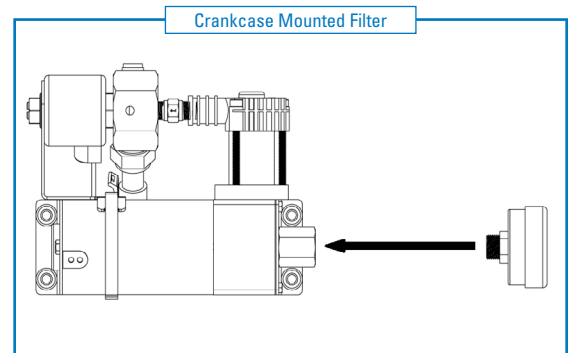

1

## 2 MOUNT COMPRESSOR ASSEMBLY

Find a suitable location on the vehicle frame to mount the single channel compressor assembly. Ensure there is adequate clearance so the kit will not interfere with surrounding components when installed.

Mount the compressor assembly to the frame in the orientation (as shown in Figure 2) using two U-bolts.

**⚠ Do NOT mount assembly with controller connector facing upwards to prevent water ingress.**

Secure with four 3/8" nylon lock nuts and washers.

Torque fasteners evenly to 27 N•m [20 ft-lbs].

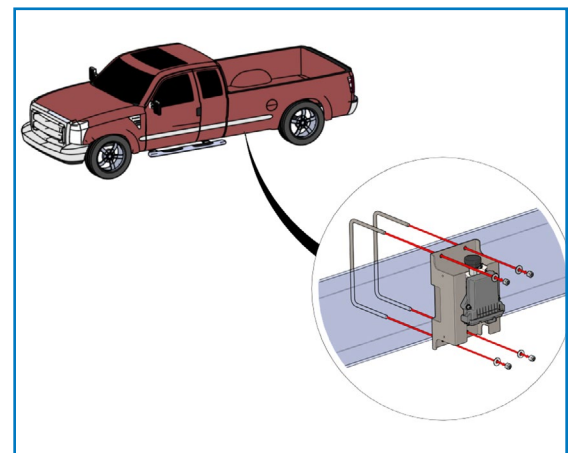

2

### 3 CONNECT WIRING HARNESS

Connect the single channel wiring harness to the mounted compressor assembly as follows:

- Connect the 2-pin and 6-pin connectors on the harness to the matching connectors on the compressor assembly
- Connect the 12-pin harness connector to the indicated socket on the controller

Ensure all connectors are fully latched and secure.

**⚠** Do NOT remove pins from connectors to pass through small sized holes.

**⚠** Unnecessary connection and disconnection of harness connectors will wear out plating on electrical contacts and negatively affect continuity

### 4 SECURE WIRING HARNESS RELAY

Included in the wiring harness assembly is a built-in sealed relay which must be secured to prevent damage over time. When all harness connectors are attached to the compressor assembly and controller, secure the relay in the nearby area that leaves the harness unstrained.

**If the relay has a built-in mounting bracket:**

- Mounting holes are provided in the bracket assembly to secure the relay.
- Attach the relay as shown (in Figure 4) using the #10-32 x 3/4" bolt, washers and nut.
- Torque bolt to 75 in-lbs [8.5 N•m]

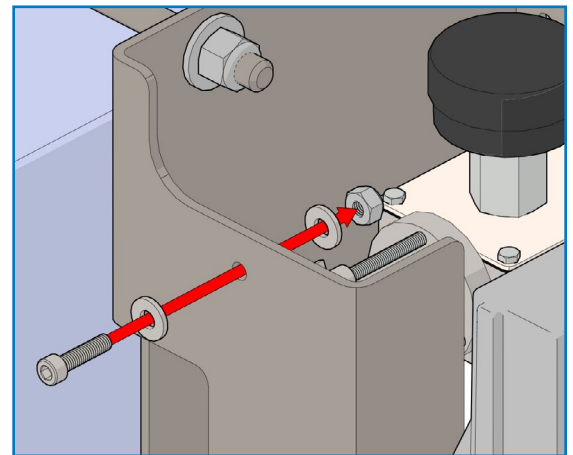

**Alternatively:**

- Drill a #21 [4 mm] pilot hole through a suitable location in the vehicle frame.
- Secure the relay using the #10 x 3/4" self-tapping screw.
- Torque screw to 75 in-lbs [8.5 N•m]

**⚠** Use caution when drilling to not damage any wiring, fuel lines or other vehicle components near or behind the drill location.

**If the relay does NOT have a built-in mounting bracket:**

- Secure relay to a rigid mounting location using provided tie straps

**⚠** Do NOT mount the relay in a way which pulls or strains the harness wires.

### 5 ROUTE WIRING HARNESS TO BATTERY

Route the wiring from the kit mounting location to the engine bay and battery. Allow adequate slack in wiring harness near connections to prevent vibrating components from straining wires.

Cut the harness to length as required for your install and secure harness away from moving parts or high heat sources with provided tie straps.

## 6 HARNESS WIRING AND INSTALLATION

Refer to the wiring schematic below (Figure 6) for making the required electrical connections:

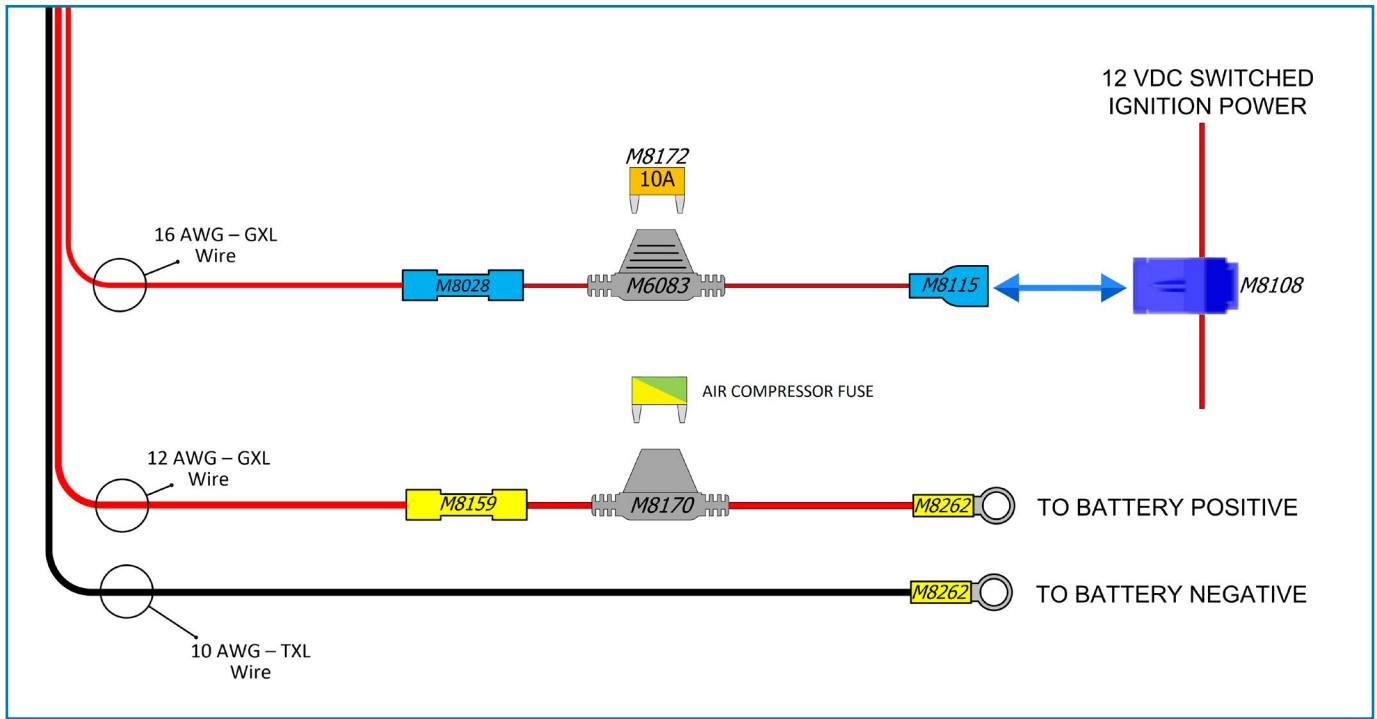

6

### CONNECT THE HARNESS TO THE BATTERY:

- Strip each wire end of the 30 Amp fuse holder, the end of the 10 AWG black wire, and the end of the 12 AWG red wire.
- Connect the 30 Amp fuse holder to the 12 AWG red wire by crimping the yellow 10-12 AWG butt connector to the wires. After crimping, apply heat to activate the heat shrink and seal the connection.
- Crimp one 10-12 AWG 3/8" ring terminal to each of the remaining wire ends on the 12 AWG red wire & 10 AWG black wire.
- Connect the ring terminals to their respective battery terminals as labelled, red to positive and black to negative.
- Insert the provided air compressor fuse into the 30 Amp fuse holder.

**NOTE:** If the negative battery terminal is not accessible, an external chassis ground may be used provided it has a clean contact area

### CONNECT THE HARNESS TO SWITCHED IGNITION POWER

Locate a source of 12 VDC switched ignition power within the engine bay. This power source will only be powered when the key is in the ON position.

- Referring to vehicle wiring schematic above; use a multimeter, or use a test lamp to identify an ignition power source

**NOTE:** A constant 12 VDC power source can be used, giving the user the ability to control their air springs while the vehicle is off. However, the controller consumes 35-80 mA in standby mode, which will slowly discharge the battery.

Step continues on following page...

**CONNECT THE HARNESS TO SWITCHED IGNITION POWER (CONTINUED)**

- Ensure the ignition is OFF before proceeding
- Crimp the T-tap connector to the 12 VDC switched power line
- Strip each end of the 15 Amp fuse holder and the end of the 16 AWG red wire
- Connect the 15 Amp fuse holder to the 16 AWG red wire by crimping the blue 14-16 AWG butt connector to the wires. Apply heat after crimping to activate the heat shrink and seal the connection.
- Crimp the 14-16 AWG spade connector to the opposite end of the fuse holder
- Insert the spade terminal into the T-tap connector, then insert the 10 Amp fuse into the 15 Amp fuse holder

**7 INSTALL INTAKE AIR FILTER**

For HP325 Series compressors with remote mounted filters (Figure 7):

- Mount the provided air filter in a clean, dry location sheltered from road spray and debris
- Connect the filter to the intake fitting on the compressor using the provided blue nylon hose
- Using the supplied tie straps, secure the airline away from heat sources and moving components to prevent damage

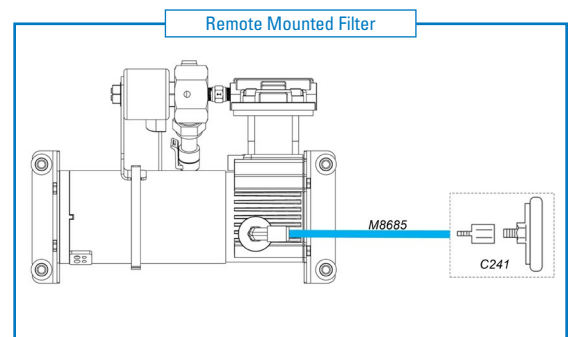

7

**8 INSTALL AIR LINES**

Connect the airline to the output air fitting attached to the solenoid block on top of the air compressor assembly (see Figure 8).



8

Route the airline from the compressor assembly to the air springs.

Connect the air line to the air springs (as shown in Figure 8 above), using the supplied ¼" Tee fitting to connect all lines.

**PLEASE NOTE:** Using scissors or wire cutters to cut the nylon airline will distort the line and cause the connection to leak. THE AIRLINE MUST BE CUT OFF SQUARELY WITH THE NYLON HOSE CUTTER OR A SHARP UTILITY KNIFE.

Use the supplied tie straps to secure all air lines away from heat sources and moving components.

## 9 APPLICATION USER GUIDE

Download the Wireless Air Spring Controls app on Google Play, the App Store, or visit [www.pacbrake.com/wireless](http://www.pacbrake.com/wireless) to download the latest version.



Once all installation has been completed, the system is ready to be paired with your mobile device:

### Pairing/Connecting the Controller with an Android Device

- Switch vehicle to ignition power or idle engine to power controller
- Ensure that Bluetooth and Location services are turned on
- In system options, open the Bluetooth page
- Refresh and search for the controller with name containing “PACBRAKE AMP”
- Select the controller for pairing – if successful, the Wireless controller will be added to the list of paired devices on your mobile device.
- Open the Wireless Air Spring Controls app. The Bluetooth toggle will illuminate to show if your device has successfully connected to the controller on the Wireless Controls kit.

### Pairing/Connecting to Controller with an iPhone™

- Ensure that Bluetooth and Location services are turned on
- Open the Wireless Air Spring Controls app. The Bluetooth toggle will illuminate to show that your device has successfully connected to the controller on the Wireless Controls kit.

**NOTE: If multiple Pacbrake app controlled devices are nearby, a window will be displayed to select a controller for connection.**

## 10 AIR SPRING INFLATION/DEFLATION

Press and hold the Inflation or Deflation button to adjust the pressure in the air springs.

The wireless app does not limit the minimum or maximum pressure in your air springs. Inflate your air springs according to your air spring manufacturer’s guidelines.

## 11 PRESETS TAB

Use the Presets Tab to save pressure presets.

Press and hold one of the preset buttons to save the current pressure value as a preset. A message on the bottom of the screen will indicate that the preset has been saved.

Use these presets anytime to quickly adjust to the desired pressure.

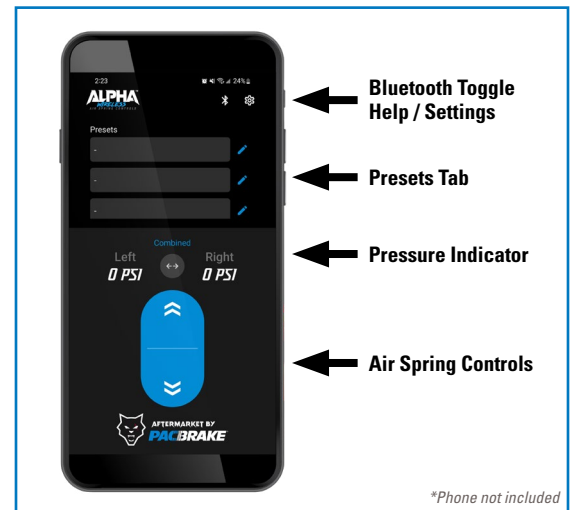

## 12 BLUETOOTH TOGGLE

The Bluetooth Toggle illuminates when it has successfully connected to the wireless controller.

Tap the Bluetooth toggle to manually connect or disconnect from the controller.

**NOTE: The app automatically connects to the controller on start-up.**

## 13 PRESSURE INDICATOR

The Pressure Indicator shows the pressure of each air spring with an accuracy of  $\pm 5\%$  over the entire range.

The presets allow for rapid adjustment to the desired pressure ( $\pm 1$  PSI)

## 14 LEAK TEST

Inflate both air springs to 90 PSI and wait for the pressure readings on the application to stabilize. Allow this pressure to remain in the system for a few minutes and ensure that it is not dropping.

If the pressure is slowly decreasing over several minutes, use soapy water on all airline connections to detect any air leaks. Repair as necessary and retest.

Inflate the air springs to a predetermined value, and on the following day recheck the pressure. If one or both the air springs have lost pressure, an air leak is present. The leak must be repaired, and then retested until no leaks exist.

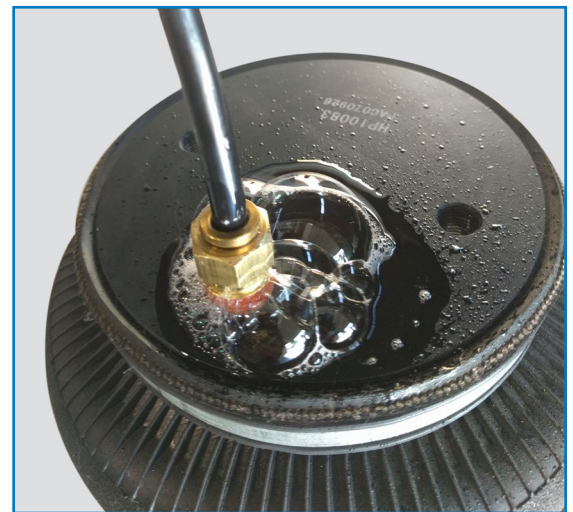

14

***Congratulations!***

***You have completed the installation.***

*Please proceed to the warranty information and operating guidelines & disclaimers below and on the following page.*

## WARRANTY

To be eligible for warranty, owner must submit their warranty card or register online within 30 days of purchase date. Refer to the Warranty Sheet included in this kit for more information.

### Operating your vehicle with Air Suspension

Air springs have minimum and maximum pressure requirements. Never operate your vehicle with less than 10 PSI in the air spring and never inflate the air springs over 100 PSI. Staying within the pressure limit will ensure maximum air spring life. Failure in doing so may void the warranty. Check the air pressure in the air springs daily for the first couple of days to ensure a leak does not develop (see Step 14: Leak Test, above). The air springs are designed to maintain the vehicles stock ride height with a load. Do not use the air springs as a means to lift the vehicle with no load. A rough ride may result.

### Servicing your vehicle with Air Suspension

When lifting the vehicle with a floor jack or hoist on the frame, never allow the air spring to limit the travel of the axle. Try to always jack the vehicle on the axle. Suspending the axle with the air spring limiting the axle travel will damage the air spring and void the air spring warranty.

## DISCLAIMER

**Driving while distracted can result in loss of vehicle control that may lead to an accident, severe personal injury, or death.**

The driver's primary responsibility is in the safe and legal operation of a vehicle, and use of any handheld devices, other equipment, or vehicle systems which take the driver's eyes, attention and focus away from the safe operation of a vehicle or which are not permissible by law should never be used during operation of the vehicle.

## LEGAL

- Apple, the Apple logo, iPhone, and iPod touch are trademarks of Apple Inc., registered in the U.S. and other countries. App Store is a service mark of Apple Inc., registered in the U.S. and other countries.
- Google Play and the Google Play logo are trademarks of Google LLC
- Android is a trademark of Google LLC
- The Android robot is reproduced or modified from work created and shared by Google and used according to terms described in the Creative Commons 3.0 Attribution License.

## FCC REGULATORY APPROVAL

**Contains Transmitter Module FCC ID: A8TBM70ABCDEFGH**

This equipment has been tested and found to comply with the limits for a Class B digital device, pursuant to part 15 of the FCC Rules. These limits are designed to provide reasonable protection against harmful interference in a residential installation. This equipment generates, uses, and can radiate radio frequency energy, and if not installed and used in accordance with the instructions, may cause harmful interference to radio communications. However, there is no guarantee that interference will not occur in a particular installation. If this equipment does cause harmful interference to radio or television reception, which can be determined by turning the equipment off and on, the user is encouraged to try to correct the interference by one or more of the following measures:

- Reorient or relocate the receiving antenna.
- Increase the separation between the equipment and receiver.
- Connect the equipment into an outlet on a circuit different from that to which the receiver is connected. Consult the dealer or an experienced radio/TV technician for help.

## IC REGULATORY APPROVAL

**Contains transmitter module IC: 12246A-BM70BLES1F2**

This device complies with Industry Canada license-exempt RSS standard(s).

**Operation is subject to the following two conditions:**

- 1) This device may not cause interference, and
- 2) This device must accept any interference, including interference that may cause undesired operation of the device.

## APPROBATION RÉGLEMENTAIRE IC

**Contient le module émetteur IC: 12246A-BM70BLES1F2**

Le présent appareil est conforme aux CNR d'Industrie Canada applicables aux appareils radio exempts de licence.

**L'exploitation est autorisée aux deux conditions suivantes:**

- 1) l'appareil ne doit pas produire de brouillage, et
- 2) l'utilisateur de l'appareil doit accepter tout brouillage radioélectrique subi, même si le brouillage est susceptible d'en compromettre le fonctionnement.