

Installation Manual



DUAL / SINGLE CHANNEL WIRELESS AIR CONTROL SYSTEMS

90 Series Air Controls Kit*

325 Series Air Controls Kit*

425 Series Air Controls Kit*

**Not compatible with Air Tanks. Air Springs sold separately.*

Giving you the ability to adjust your air spring pressure both independently and simultaneously from your phone (or remote) with the touch of a button. It's the perfect means to control your vehicle's air suspension system from inside or outside your vehicle!

Thank you and congratulations on the purchase of a Wireless Air Controls kit. Please read the entire manual prior to starting the installation to ensure you can complete it once started.

SAFETY WARNINGS!

Please read and abide the instructions found in this manual, paying close attention to the helpful, cautionary or dangerous warning icons highlighting important safety recommendations and maintenance suggestions throughout this manual.

HELPFUL INSTALL TIP
 Additional information that could potentially make the job a little easier.

PLEASE USE CAUTION
 Unsafe practices could result in damage to you or your vehicle, or others.



DANGER WARNING
 Hazards which could result in severe personal injury or death.

IMPORTANT TO KNOW WHEN USING WITH AIR SUSPENSION

An air suspension kit will not increase the GVWR (Gross Vehicle Weight Rating), as the GVWR is determined by the vehicle manufacturer. Do not exceed the maximum capacity listed by the vehicle manufacturer.

For safe and proper operation of the vehicle, never exceed a maximum of 100PSI in the air springs. Staying under the pressure limit will ensure maximum air spring life.

Failure in doing so may result in damage to your vehicle and/or a void warranty.

-  Serious personal injury or death may result from an air spring failure or accident due to improper installation or air spring pressure operation or maintenance.
-  Inflating an unsecured air spring is dangerous. If it bursts, it could be hurled into the air with explosive force resulting in serious personal injury or death. Never inflate an air spring unless it is secured to the vehicle.
-  Removing and replacing air springs can be dangerous. This is only a job for a qualified service professional. Never perform air spring service procedures without proper training, tools, and equipment.

BEFORE STARTING THE INSTALLATION

- Ensure the application information is correct for the make, model and year of the vehicle you are installing the kit on.
- It is recommended to use a good quality anti-seize on all fasteners. This will reduce the chance of corrosion on the fasteners and will help facilitate removal, if required at a later date.
-  **PLEASE NOTE: This kit contains push-to-connect fittings; using scissors or wire cutters to cut the nylon air line will distort the line and cause the connection to leak. The air line must be cut off squarely with the hose cutter provided in this kit, or a sharp utility knife. Failure to do so may void the warranty.**



PLEASE NOTE: This manual is used across multiple kit numbers. Installation step images may vary depending on your kit but the procedure remains the same across all part numbers (unless specifically noted in a step).

KIT CONTENTS

Please confirm the items below are provided in your kit before starting the installation. Reference the wiring diagram on the following page for part assembly.

AIR COMPRESSOR		QTY	PART #
A	90 Series 12 VDC Compressor	1	HP10667
	325 Series 12 VDC Compressor		HP10679
	425 Series 12 VDC Compressor		HP10669



KIT CONTENTS		QTY	PART #
B	Wireless Manifold Assembly	1	HP10666-NT
C	Harness, Wireless Air Controls	1	HP10658
D	Screw, Self drilling, #10 x 1.25"	10	HP2116
E	Tee Fitting, 1/4" Push-to-Connect	2	HP2089
F	Plug Fitting, 1/8" NPT	1	HP2074
G	Fuse Tap, Micro2	1	M8999
H	Fuse Tap, Mini	1	M8998
I	Fuse, Micro2, 10 Amp	1	M9044
J	Fuse, Mini, 10 Amp	1	M8172
K	Fuse, Mini, 30 Amp	1	M8180
L	3/8" Ring Terminal, 10 – 12 AWG	1	M8262
M	Butt Connector, 10 – 12 AWG	1	M8159
N	Heat Shrink, 0.3" x 1"	1	M8001
O	Heat Shrink, 0.3" x 2"	1	M8266
P	Nylon Air Line, Black, 30 Feet	1	M9047-30
Q	Inlet Air Filter	1	C241
R	Tube Cutter	1	HP10208
S	Zip Tie	24	C11618



REQUIRED TOOLS

- Ratchet and Socket Set
- Torque Wrench
- Hose Cutter (included) or Sharp Utility Knife
- Multimeter or Test Light
- Wire Stripper/Cutter
- Terminal Crimper
- Heat Gun
- Spray Bottle with Dish Soap/Water
- Hand-held Power Drill
- 5/16" nut driver for Power Drill

INSTALLATION OVERVIEW DIAGRAM: DUAL CHANNEL SHOWN

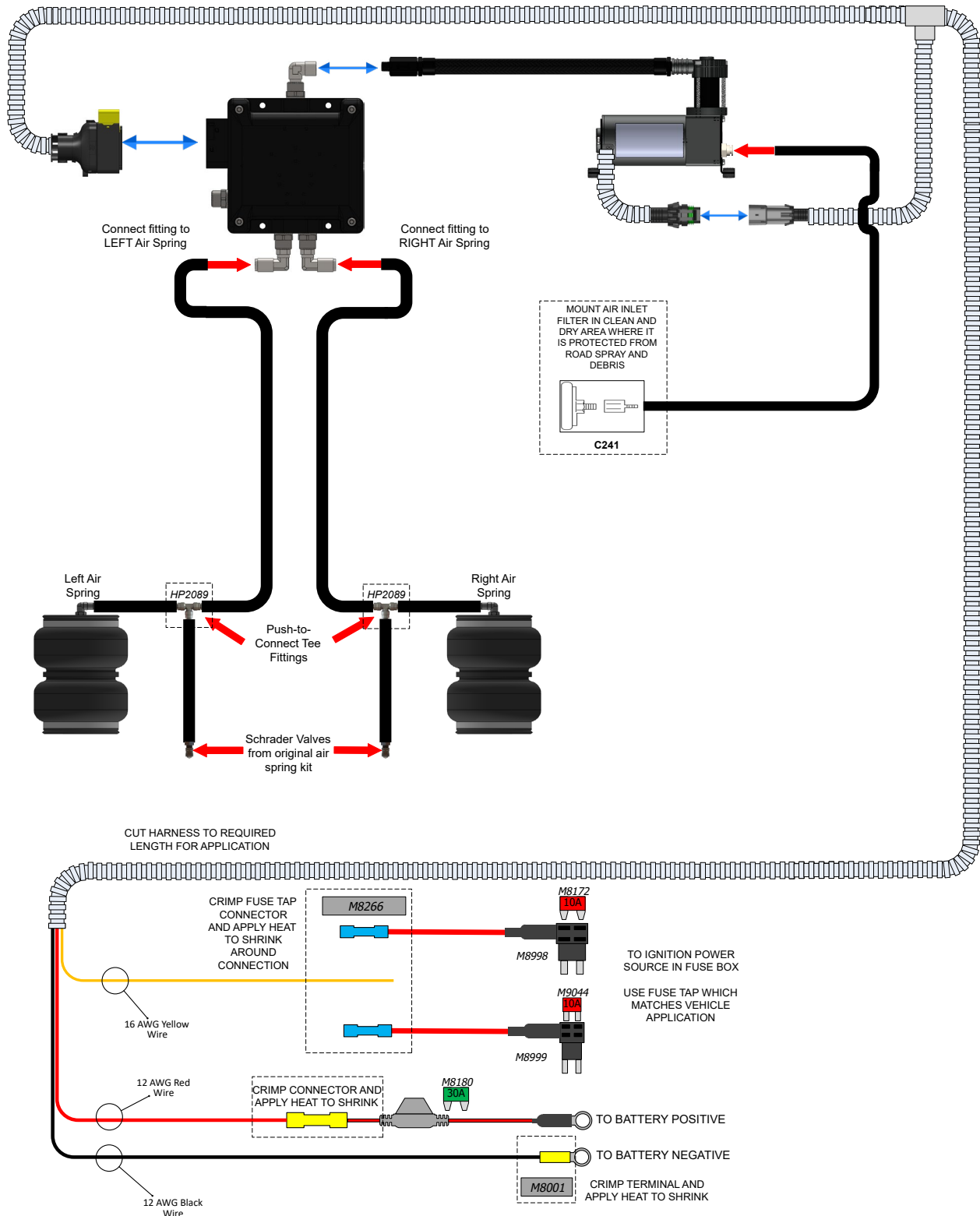

INSTALLATION INSTRUCTIONS

1 MOUNT MANIFOLD AND AIR COMPRESSOR ASSEMBLY

This wireless air control kit is designed to be versatile with a universal mounting style.

The kit features an air compressor, and a wireless manifold controller which can be mounted in any location by drilling holes, or by using the provided self drilling screws. The air compressor can be mounted in any orientation, and various size air compressors are available to suit various power needs and space limitations.

- ⚠ **PLEASE NOTE:** *The compressor and wireless manifold controller must be mounted in a position that the output from the compressor can be threaded into the input of the wireless manifold controller.*
- ⚠ **Do NOT** mount controller or compressor assembly directly on engine or other components exhibiting harsh vibration.
- ⚠ **Do NOT** mount the controller or compressor assembly in areas where ambient temperature exceeds 70°C [158°F]

Determine a suitable mounting location for the kit with the following requirements:

- Mounting surface must be rigid.
- Location should protect the kit components from debris and excessive moisture.
- Kit must not interfere with surrounding components during vehicle operation.
- Surrounding area must have adequate clearance to route the wiring harness and air lines without causing sharp bends

Possible kit mounting locations can include:

- Along the frame rail (as shown in Figure 2 below)
- Inside the engine bay
- Inside the truck bed

2 MOUNT WIRELESS MANIFOLD CONTROLLER AND AIR COMPRESSOR

Find a suitable location to mount the manifold and compressor assembly, ensuring there is adequate clearance so the kit will not interfere with surrounding components when installed.

- + *Optimum mounting location is typically on the passenger side frame rail beneath the vehicle cab.*
- ⚠ **Mount with the harness connector facing down to help prevent water pooling on the connector and possible water ingress over time.**

For your convenience, 10 self drilling screws have been provided in the kit to allow for easy installation on the frame rail (as shown in Figure 2).

- ⚠ **Do NOT** overtighten the self drilling screws as this can cause damage to the Wireless Manifold Controller

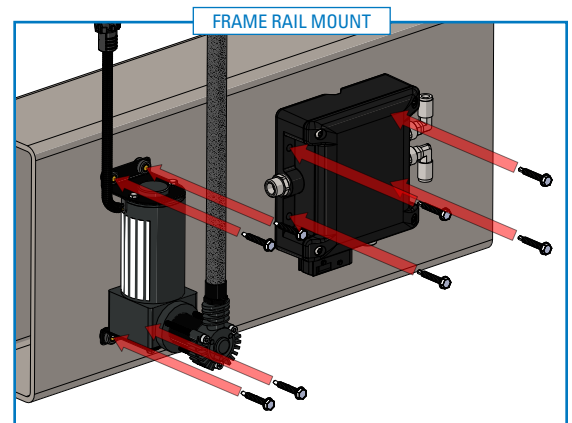

2

3 CONNECT COMPRESSOR TO WIRELESS MANIFOLD CONTROLLER

Apply thread sealant or Teflon-tape to the treads on the braided compressor air line, and thread into the open inlet of the Wireless manifold Controller (as shown in Figure 3).

Hand tighten fitting until snug. Then, using a wrench, turn an additional 1-2 full turns to ensure a fully sealed connection.

! *Ensure braided airline from compressor is installed without hard bends when connected to the wireless manifold*

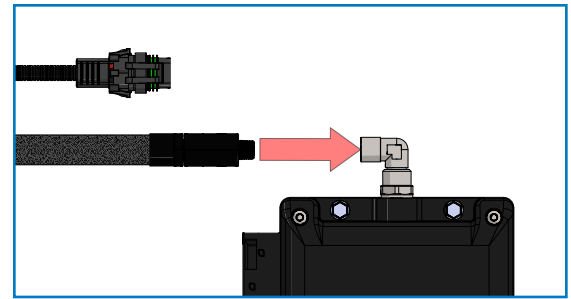

*NPT Air Fitting may differ between kits

3

4 CONNECT WIRING HARNESS TO MANIFOLD AND COMPRESSOR

Ensure the yellow latching slide is in the raised “unlocked position” (highlighted in Figure 4A with a blue circle)

Push the harness connector onto the mating socket (as shown in Figure 4A with a white arrow) – the connector will stop approximately halfway on the socket.

Continue pushing the connector while simultaneously pushing down on the yellow latching slide to fully seat and lock the connector (a fully seated connection should appear as shown in Figure 4B).

Finally, insert the compressor harness into its receptacle by pressing then together until fully latched (see example in Figure 4C).

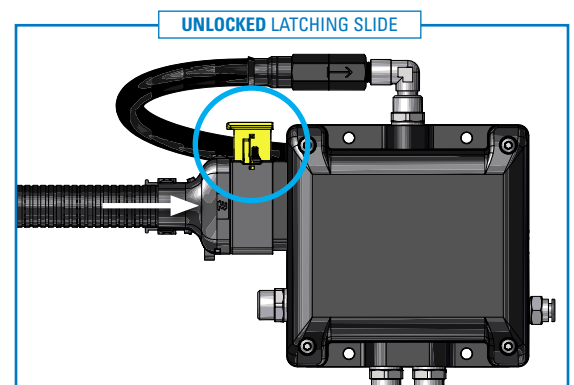

4A

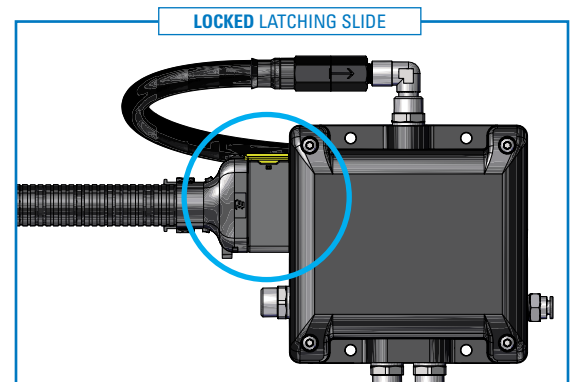

4B

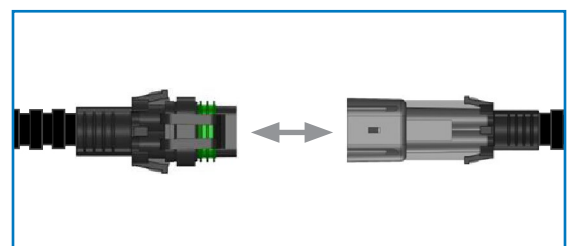

4C

5 INSTALL AIR LINES AND REMOTE INLET FILTER

! **PLEASE NOTE:** This kit contains **push-to-connect fittings**; using scissors or wire cutters to cut the nylon air line will distort the line and cause the connection to leak. The air line must be cut off squarely with a hose cutter or a sharp utility knife.

Route the air lines from the wireless air manifold to the air springs depending on your actuation preferences (see Figure 3A / 3B).

Both Single Channel and Dual Channel modes have their benefits:

DUAL CHANNEL

- ▶ Control each air spring's pressure independently with separate buttons.
- ▶ Allows for more accurate side-to-side leveling of the vehicle.

SINGLE CHANNEL

- ▶ Control the pressure of both air springs with one button.
- ▶ Ease of use, simply set the system pressure.

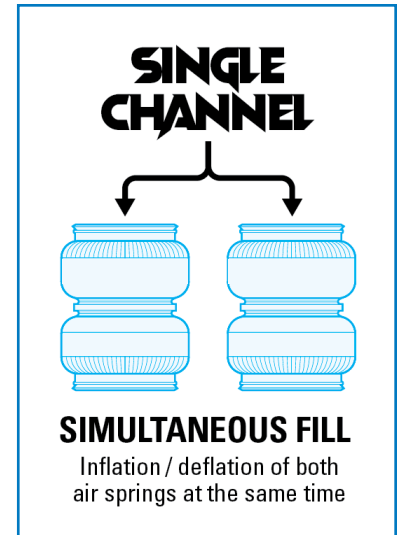
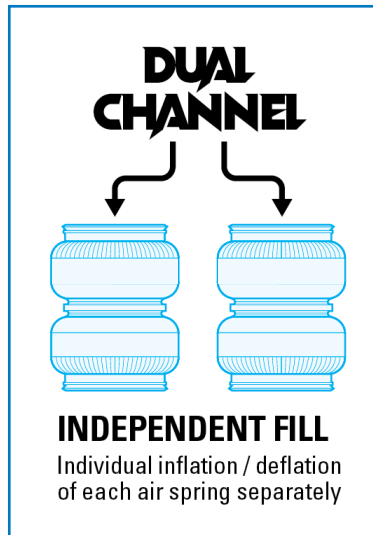

DUAL CHANNEL

Connect the nylon tubing to both the left side and the right side channel's push-to-connect fittings.

Route both tubing lines from the wireless manifold controller to the rear of the vehicle, securing the lines with the provided zip ties.

! **Be sure to avoid any moving parts, hot areas or potential pinch points.**

Route the left channel tubing to the left air spring.

Connect the left side Schrader valve from the original air spring kit to the left side nylon tubing using a supplied push-to-connect tee (see Figure 5A for details).

Route the right channel tubing to the right air spring.

Connect the right side Schrader valve from the original air spring kit to the right side nylon tubing using a supplied push-to-connect tee.

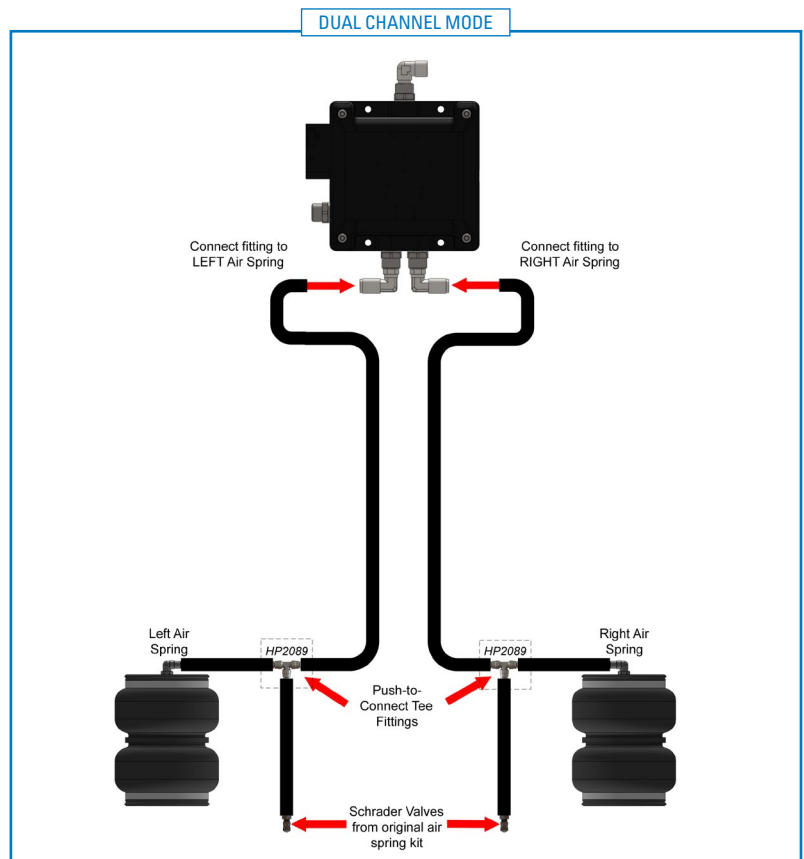

SINGLE CHANNEL continues on the following page

5A

SINGLE CHANNEL

Remove 90° push-to-connect fitting from the right side channel, and replace it with the 1/8" NPT plug supplied in this kit.

Connect the Nylon tubing to the left side channel's push-to-connect fitting.

Route the tubing line from the Wireless Manifold Controller to the rear of the vehicle, securing the line with the provided zip ties.

! *Be sure to avoid any moving parts, hot areas or potential pinch points.*

Use a push-to-connect tee fitting and route a nylon tubing line to both the left side and right side air springs (see Figure 5B for details).

Connect the left line to the left air spring.

Connect another push-to-connect tee fitting into the right side tubing line. Connect the tee fitting to the right air spring with a length of nylon tubing.

Connect the Schrader valve from the original air spring kit to the right side line's tee fitting.

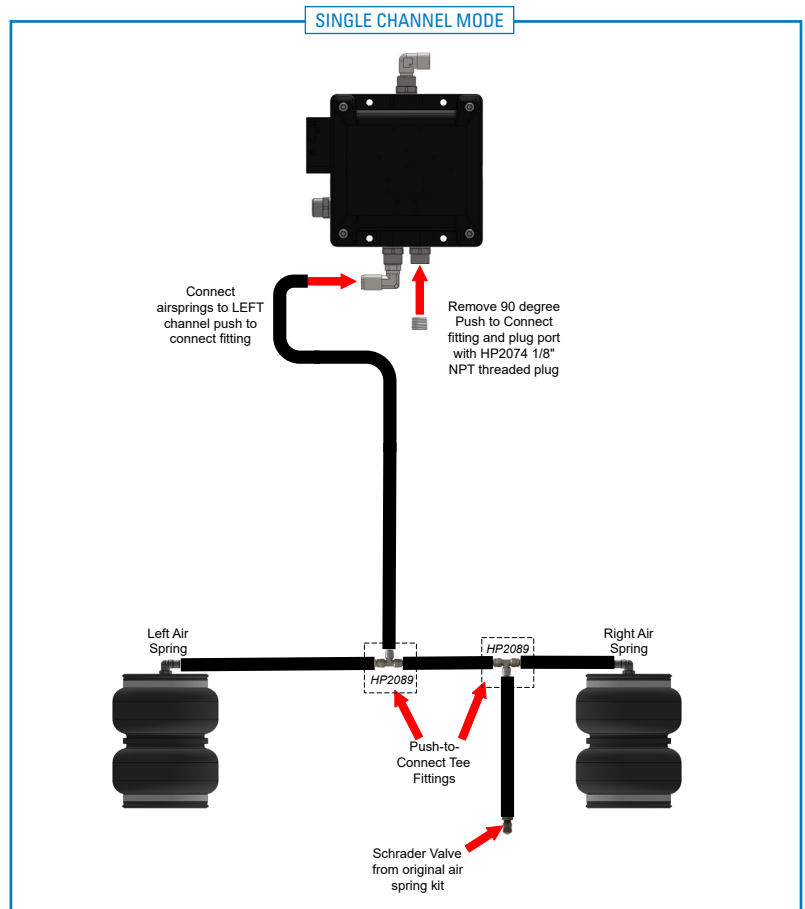

5B

INSTALLING REMOTE AIR FILTER

Find a clean and dry location sheltered from road spray and debris to install the remote air filter.

Screw the barbed tube fitting onto the remote air filter hand tight, then attach the air line to the barbed fitting (See Figure 5C).

+ *Slightly heating the air line will allow for easier installation onto barbed fitting.*

Route the air line to the inlet port of the air compressor.

Use the supplied zip ties to secure all air lines away from any heat sources and moving components.

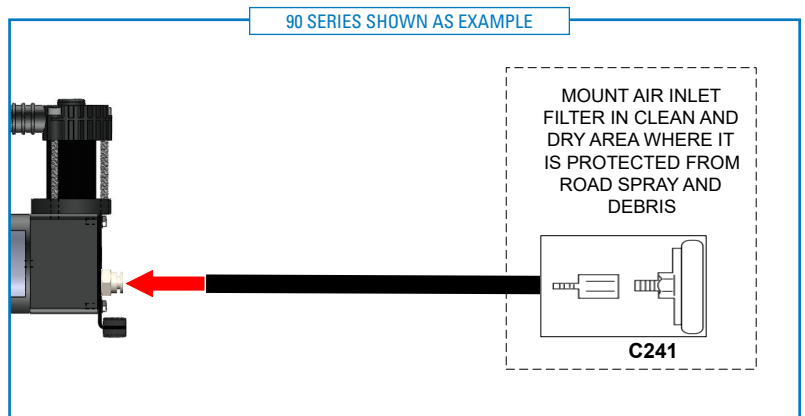

5C

6 ROUTE WIRING HARNESS

Route the preassembled wiring harness along, or in the truck frame, up through the engine compartment, to the battery.

! *Be sure to keep it away from all hot or moving parts.*

Use the supplied zip ties to secure it completely to prevent it from coming loose.

Trim the excess wire length, making sure to leave some extra length to ensure the wiring can reach the battery and fuse box.

ASSEMBLING HARNESS WIRING

Open the fuse box under the hood of the vehicle. Determine which "style" of fuse tap to use based on the size of an existing fuse's blades (see Figure 6A for "style" clarification).

Slide the 2" heat shrink onto the fuse tap wire before crimping to the yellow SWITCHED POWER wire on the wiring harness (see Figure 6B). Ensure the heat shrink is in place, covering the entire connector, then apply heat to shrink and seal the connection.

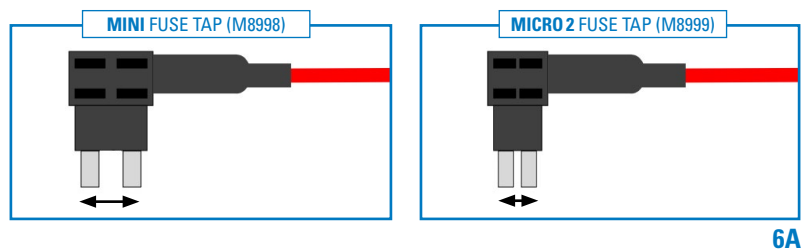

Take the POSITIVE (+) red wire of the harness and the preassembled fuse holder with 3/8" ring terminal assembly (included with the wireless harness) and crimp them together using a supplied butt splice connector (see Figure 6C for assembly). Apply heat to the butt splice connector to shrink and seal the connection. Install the 30A fuse into fuse holder.

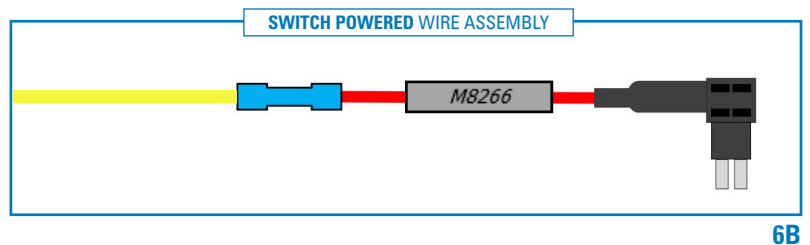

Slide the 1" heat shrink onto the remaining NEGATIVE (-) black wire of the harness before crimping a 3/8" ring terminal on to the end of it (see Figure 6D). Ensure the heat shrink is in place, covering the entire connector, and apply heat to shrink and seal the connection.

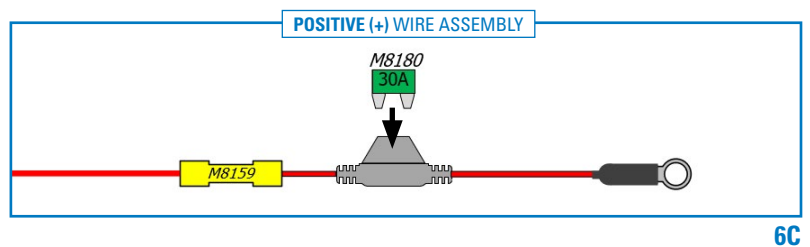

CONNECT THE HARNESS TO THE BATTERY:

Connect the NEGATIVE (-) black wired ring terminal to an available connection point on the negative battery terminal.

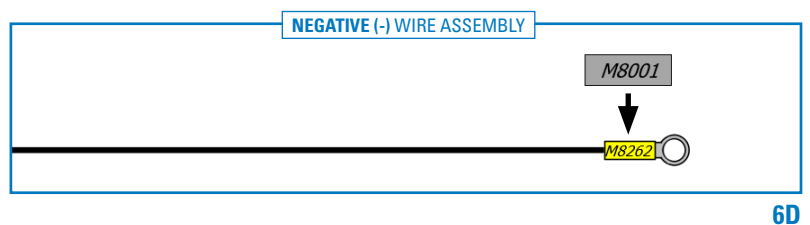

Following the same procedure for the POSITIVE (+) red wired ring terminal, connecting it to an available connection point on the positive battery terminal.

Step continues on the following page

FUSE TAP INSTALLATION:

Determine a switched ignition fuse, by using a voltmeter on the top of the fuse blades. The target fuse must have a current rating of 15 Amps or greater. It is strongly recommended to avoid any critical circuits of the vehicle such as ABS, air bags, advanced driver systems, or communication/control modules. A 12V accessory circuit is generally the best option.

Turn the ignition on, (without starting the engine) and using a voltmeter, determine if there is power to the fuse.

Check again with the ignition off, to ensure that there is now no power to the fuse, which indicates it is indeed switched power. Remove the fuse currently occupying the location you intend to use.

Turn the ignition back on and determine which side of the receptacle has power. Note this side.

Turn off the ignition power to vehicle.

Place the removed fuse in the LOWER slot of the fuse tap (shown with a red arrow in Figure 6E).

Place the appropriate size 10A fuse in the TOP slot of the fuse tap (shown with a black arrow in Figure 6E).

Orient the fuse tap so the non-wire-side fuse prong will connect to the powered side of the fuse receptacle (shown circled in Figure 6E). Fully seat fuse tap into fuse receptacle.



6E

7 TESTING THE CONNECTION

Turn the ignition on.

Open up the app on your phone or on the remote (only included in “-R” kits) to check for power to the controller.

Turn the ignition off.

The controller should power off and not be visible on the app.

If controller does not turn off when the ignition is off, remove the fuse tap and select a different fuse to use.

! *PLEASE NOTE: A constant 12 VDC power source can be used, giving the user the ability to control their air springs while the vehicle is off. However, the controller consumes 35-80 mA in standby mode, which will slowly discharge the battery.*

8 OPTIONAL: CONNECTING EXTERNAL PRESSURE GAUGE

The wireless air controls system can connect to an external pressure gauge to allow for constant pressure monitoring without needing to use the mobile app.

In the harness near the manifold are three signal wires which are connected to the pressure sensors inside the manifold.

Signal wires from an external digital air pressure gauge can be connected to these wires to display the following pressure feedback:

YELLOW WIRE	RIGHT Air Spring Pressure
BLUE WIRE	Air Tank Pressure (<i>not compatible with this kit</i>)
GREY WIRE	LEFT Air Spring Pressure
BLACK WIRE	GROUND Reference for Pressure Signals

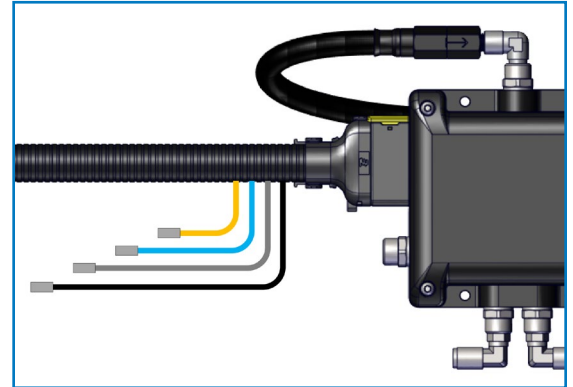

8

Ensure all wires are properly insulated and sealed.

! *PLEASE NOTE: Pressure gauge must be compatible with 0 – 200 psi, 5V pressure sensors with 0.5 – 4.5V ratiometric output.*

9 CHECK SYSTEM FOR LEAKS

Inflate both air springs to 90 psi (60 psi for in-coil bags), then use a mixture of dish soap and water on all air line connections to detect any air leaks. Large, expanding bubbles indicate a leak (as shown in Figure 9).

Repair as necessary and retest.

Inflate air springs to a predetermined value and on following day recheck pressure. If one / both of air springs have lost pressure, an air leak is present.

! *Leak must be repaired, and then retested until no leaks exist.*

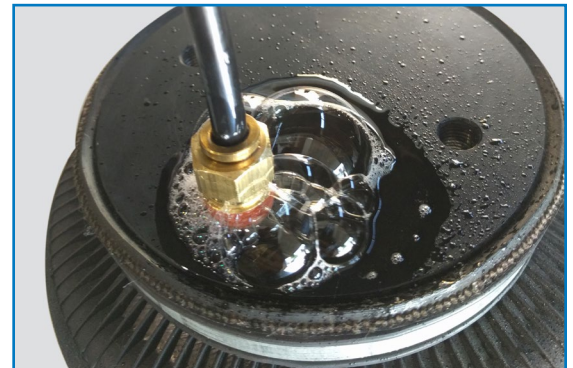

**Air Spring & NPT Air Fitting may differ between kits*

9

CONGRATULATIONS! You have completed the install

After Installation & Legal continues on the following page.

.....

AFTER COMPLETING THE INSTALLATION

Do not exceed maximum vehicle payload. Failure to do so may result in failure of the air suspension kit and/or damage to your vehicle.

.....

OPERATING YOUR VEHICLE WITH AIR SUSPENSION

Air springs have minimum and maximum recommended pressure requirements:

PART #	SPRING STYLE	SPRING TYPE	MIN PSI	MAX PSI
HP10189	In-Coil	STANDARD DUTY	5 PSI	70 PSI
HP10560		STANDARD DUTY		
HP10001	Sleeve Style	STANDARD DUTY	10 PSI	100 PSI
HP10173		STANDARD DUTY		
HP10199		STANDARD DUTY		
HP10083	Single Convoluted	HEAVY DUTY	5 PSI	100 PSI
HP10083J		HEAVY DUTY with JOUNCE BUMPER	0 PSI* / 5 PSI	100 PSI
HP10000	Double Convoluted	HEAVY DUTY	5 PSI	100 PSI
HP10000J		HEAVY DUTY with JOUNCE BUMPER	0 PSI* / 5 PSI	100 PSI
HP10068	Large Double Convoluted	HEAVY DUTY	5 PSI	100 PSI
HP10438	Double Convoluted	EXTREME DUTY	5 PSI	100 PSI
HP10438J		EXTREME DUTY with JOUNCE BUMPER	0 PSI* / 5 PSI	100 PSI

* Springs with a jounce bumper can be run at zero PSI when vehicle is unloaded only

For safe and proper operation, never operate the vehicle over the maximum listed PSI in the air springs. Staying under the pressure limit will ensure maximum air spring life. **Failure in doing so may result in damage to your vehicle and/or a void warranty.**

! *It is recommended to check the air pressure in your air springs daily for first couple of days to ensure a leak has not developed.*

Air springs are designed to maintain the vehicle's stock ride height with a load. Do not use the air springs as a means to lift vehicle with no load. This will result in a harsh ride.

SERVICING YOUR VEHICLE WITH AIR SUSPENSION

When lifting the vehicle with a floor jack or hoist on the frame, never allow the air spring to limit the travel of the axle. Try to always jack the vehicle on the axle. Suspending the axle with the air spring limiting the axle travel will damage the air spring and void the air spring warranty.

WARRANTY

See additional warranty included with this kit for details.

.....

DISCLAIMER

Driving while distracted can result in loss of vehicle control that may lead to an accident, severe personal injury, or death.

The driver's primary responsibility is in the safe and legal operation of a vehicle, and use of any hand-held devices, other equipment, or vehicle systems which take the driver's eyes, attention and focus away from the safe operation of a vehicle or which are not permissible by law should never be used during operation of the vehicle.

.....

LEGAL

- Apple, the Apple logo, iPhone, and iPod touch are trademarks of Apple Inc., registered in the U.S. and other countries. App Store is a service mark of Apple Inc., registered in the U.S. and other countries.
- Google Play and the Google Play logo are trademarks of Google LLC.
- Android is a trademark of Google LLC.
- The Android robot is reproduced or modified from work created and shared by Google and used according to terms described in the Creative Commons 3.0 Attribution License.

FCC REGULATORY APPROVAL

Contains Transmitter Module FCC ID: 2ADHKWBZ451

This equipment has been tested and found to comply with the limits for a Class B digital device, pursuant to part 15 of the FCC Rules. These limits are designed to provide reasonable protection against harmful interference in a residential installation. This equipment generates, uses, and can radiate radio frequency energy, and if not installed and used in accordance with the instructions, may cause harmful interference to radio communications. However, there is no guarantee that interference will not occur in a particular installation. If this equipment does cause harmful interference to radio or television reception, which can be determined by turning the equipment off and on, the user is encouraged to try to correct the interference by one or more of the following measures:

- Reorient or relocate the receiving antenna.
- Increase the separation between the equipment and receiver.
- Connect the equipment into an outlet on a circuit different from that to which the receiver is connected. Consult the dealer or an experienced radio/TV technician for help.

IC REGULATORY APPROVAL

Contains transmitter module IC: 20266-WBZ451

This device complies with Industry Canada license-exempt RSS standard(s).

Operation is subject to the following two conditions:

- 1) This device may not cause interference, and
- 2) This device must accept any interference, including interference that may cause undesired operation of the device.

APPROBATION RÉGLEMENTAIRE IC

Contient le module émetteur IC: 20266-WBZ451

Le présent appareil est conforme aux CNR d'Industrie Canada applicables aux appareils radio exempts de licence.

L'exploitation est autorisée aux deux conditions suivantes:

- 1) l'appareil ne doit pas produire de brouillage, et
- 2) l'utilisateur de l'appareil doit accepter tout brouillage radioélectrique subi, même si le brouillage est susceptible d'en compromettre le fonctionnement.