

PART NUMBER
SSA16



BEFORE YOU BEGIN

TOOLS REQUIRED

- > Floor Jack
- > Safety Jack Stands
- > Wheel Chocks
- > 1-1/16" Wrench/Sockets
- > 1-1/8" Wrench/Sockets
- > Heavy Duty Clamps or SuperSprings Installation Tool

PARTS LIST - STANDARD INSTALLATION

Item	Part #	Description	QTY
A	102016	SSA16 Leaf Spring	2
B	PSP-7	Polyurethane Spring Pad	2
C	112183	Lock Down U-Bolt	2
D	112185	Lock Down Clamp	2
E	512302	3/8-16 Locking Flange Nut	4
F	112142	Steel Sleeve	4
G	112190	HDPE Roller	4
H	122404	Shackle Leg 45°	4
I	122409	Shackle Leg 90°	4
J	112146	3/4" Nylon Flat Washer	12
K	112144	3/4-10 x 3 1/2" Hex Bolt Grade 8	4
L	112179	3/4-10 x 4 1/2" Hex Bolt Grade 8	2
M	112143	3/4-10 x 5" Hex Bolt Grade 8	2
N	112145	3/4-10 Nylok Nut Grade 8	6
O	112180	Top-Lock Distorted-Thread Locknut	2
P	112141	Polyurethane Bushing	8

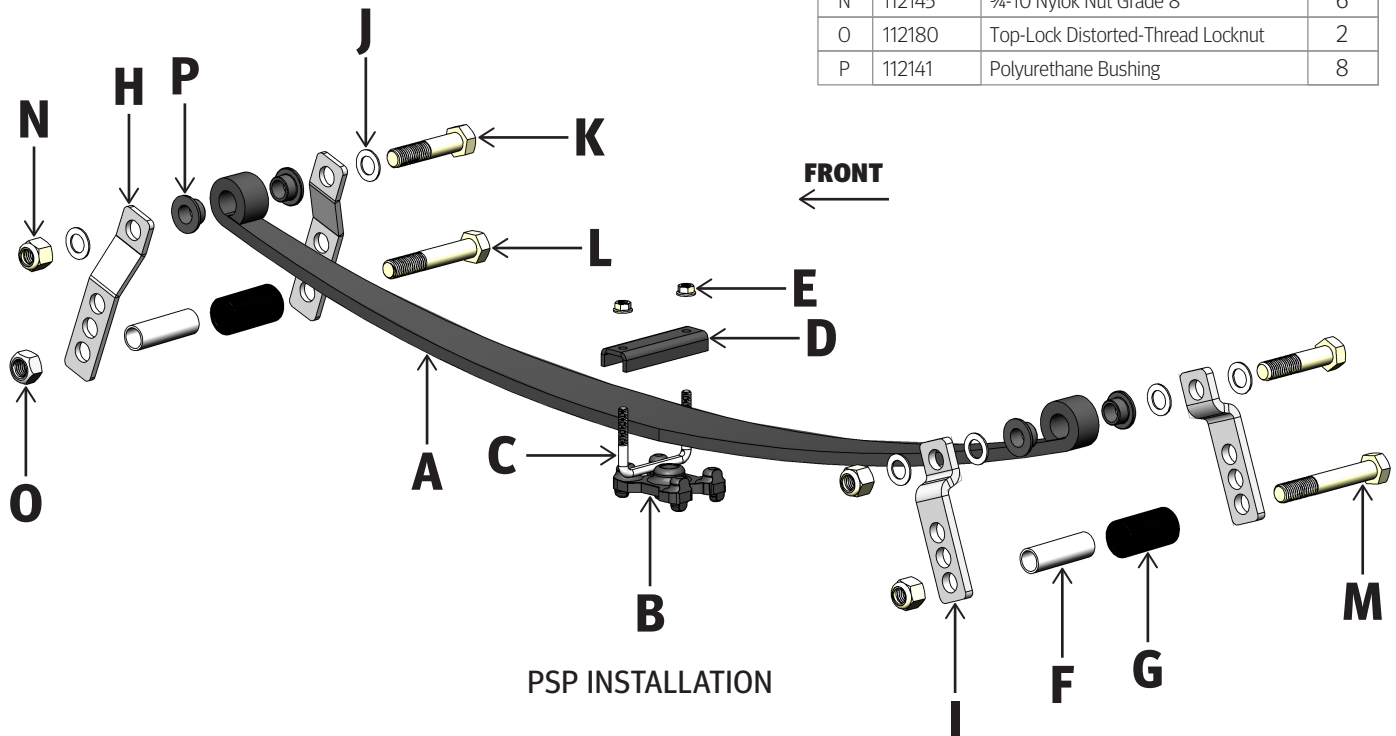

Part Number: SSA16

Product Line: SUPERSPRINGS

Page 1

SuperSprings
International, Inc.
505 Maple Avenue
Carpenteria, CA 93013

Installation Support
+1 (800) 898-0705
support@supersprings.com

superspringsint.com

SAFETY NOTICE: We recommend installation be done by a professional or persons with sound mechanical knowledge.

WARNING: These instructions are a general guide for installation. SuperSprings International, Inc. assumes no liability for the actual installation process. Consumers and installers should apply common automotive safety practices when raising and working on any vehicle. **Do not put yourself in a position where, if the vehicle were to move unexpectedly, you may be injured.** SuperSprings' products are designed to improve vehicle ride quality. Do not load any vehicle beyond the manufacturer's specifications.

Never exceed the manufacturer's Gross Vehicle Rating (GVWR) located on your vehicles identification tag.

BEFORE INSTALLATION: Ensure the vehicle is on a level surface, the parking brake is ON, with the ignition OFF, and place blocks in front of and behind the front tires to prevent the vehicle from moving.

DURING AND/OR AFTER INSTALLATION: Ensure emergency brake cables are not touching the SuperSprings. Secure any cables out of the way with zip ties or by re-routing. Ensure all A/C lines, brake cables, and frame are clear of contact or interference.

REV. 2.0 | MAY 2022

PART NUMBER
SSA16



BEFORE YOU BEGIN

PRIMARY APPLICATIONS

- > Chevrolet Express 3500 4 X 2
(1996 - present)
- > Chevrolet Silverado 2500 4 X 2 & 4 x 4
(1999 - 2000)
- > Chevrolet Silverado 2500 HD 4 X 2* & 4 X 4*
(2011 - present)
- > Chevrolet Silverado 3500 HD 4 X 2* & 4 X 4*
(2011 - present)
- > Ford F-250 4 X 2 & 4 x 4
(1980 - 1999)
- > Ford F-250 HD 4 X 2 & 4 x 4
(1997 - 1997)
- > Ford F-250 Super Duty 4 X 2 & 4 x 4
(2011 - 2016)
- > Ford F-250 Super Duty 4 X 2 & 4 x 4
(1999 - 2007)
- > Ford F-350 4 X 2 & 4 x 4
(1980 - 1997)
- > Ford F-350 Super Duty 4 X 2 & 4 x 4
(2011 - 2016)
- > Ford F-350 Super Duty 4 X 2 & 4 x 4
(1999 - 2007)
- > GMC Savana 3500 4 X 2
(1996 - present)
- > GMC Sierra 2500 4 X 2 & 4 x 4
(1999 - 2000)
- > GMC Sierra 2500 HD 4 X 2* & 4 x 4*
(2011 - present)
- > GMC Sierra 3500 HD 4 X 2* & 4 x 4*
(2011 - present)

*MXKT Required

PARTS LIST - WITH MOUNTING KIT OPTION

Item	Part #	Description	QTY
Q	112211	MTKT Mounting Bracket	2
R	112203	MTKT Clamp Plate	4
S	112202	3" x 4" Square U-Bolt	4
T	112130	½" Flat Washer	8
U	112126	½"-13 Lock Nut	8
V	112282	Spring Clamp Plate	4
W	112208	5/16-18 Lock Nut	4
X	512244	5-1/16 Flat Washer	8
Y	112214	5/16-18 x 2" Hex Bolt	4
	112215	5/16-18 x 2-½" Hex Bolt	4

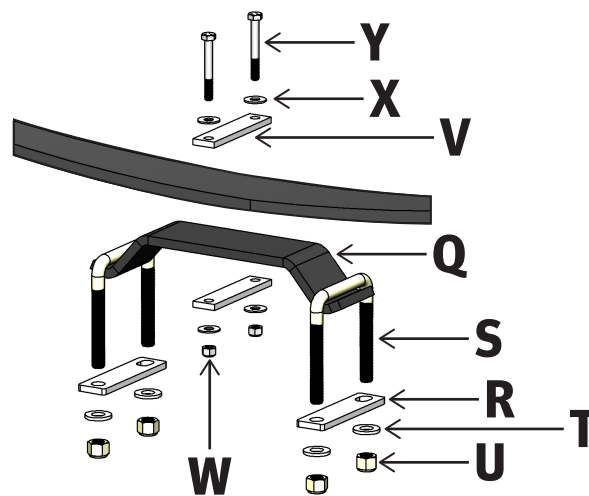

MOUNTING KIT INSTALLATION

Part Number: SSA16

Product Line: SUPERSPRINGS

Page 2

SuperSprings
International, Inc.
505 Maple Avenue
Carpinteria, CA 93013

Installation Support
+1 (800) 898-0705
support@supersprings.com

superspringsint.com

SAFETY NOTICE: We recommend installation be done by a professional or persons with sound mechanical knowledge.

WARNING: These instructions are a general guide for installation. SuperSprings International, Inc. assumes no liability for the actual installation process. Consumers and installers should apply common automotive safety practices when raising and working on any vehicle. **Do not put yourself in a position where, if the vehicle were to move unexpectedly, you may be injured.** SuperSprings' products are designed to improve vehicle ride quality. Do not load any vehicle beyond the manufacturer's specifications.

Never exceed the manufacturer's Gross Vehicle Rating (GVWR) located on your vehicles identification tag.

BEFORE INSTALLATION: Ensure the vehicle is on a level surface, the parking brake is ON, with the ignition OFF, and place blocks in front of and behind the front tires to prevent the vehicle from moving.

DURING AND/OR AFTER INSTALLATION: Ensure emergency brake cables are not touching the SuperSprings. Secure any cables out of the way with zip ties or by re-routing. Ensure all A/C lines, brake cables, and frame are clear of contact or interference.

REV. 2.0 | MAY 2022

PART NUMBER

SSA16



IMPORTANT NOTICE: Your part may have been loosely preassembled to show the final product as it will be once installed on your vehicle. Please disassemble the product before proceeding to the installation.

INSTALLATION

1. Positioning the vehicle – Vehicle must be on level solid surface. Ensure emergency brake is ON and Ignition is OFF. Chock both front and rear of the front tires to prevent the vehicle from moving.
 2. Jack up vehicle – elevate and support the frame securing with jack stands so that the axle is hanging with tires slightly off the ground. Wheel removal is suggested ONLY were bodies are mounted.
 3. Spring Orientation – The SSA16 does not have a dedicated front/rear. However, in most cases, the longer shackle [ITEM H] should be toward the front, and the shorter shackle [ITEM I] should be used in the position with the least amount of clearance above. The threaded ends of the spring eye bolts should be pointing outboard, away from the frame.
 4. Remove Shackle Roller Assemblies – Using 1 1/16" and 1 1/8" tools, wrenches / sockets / ratchet, remove and set aside the bolts [ITEM L & M] and nuts [ITEM O & N] rollers [ITEM G] and sleeves [ITEM F] from the front and rear of the shackles. Rotate the shackles toward the center and parallel to the spring.
- 5. Spring Mounting**
- PSP Install** - Place PSP-7 [ITEM B], centered between the u-bolts, on top of the factory spring-plate. The PSP-7 is double sided, so whichever side fits the spring plate better is the side that should face down. Per the diagram, place the square u-bolt [ITEM C] around the spring so the threads are facing up. Install the clamping plate [ITEM D] onto the u-bolt with the open side down and center on spring blade as shown. Using 9/16" tools, wrenches / sockets / ratchet, install the 3/8 flange nuts [ITEM E]. Only partially tighten the nuts so that the clamp assembly can still be moved freely on the spring blade.
- OR**
- MTKT or MXKT Install** - Place Mounting Kit Bracket [ITEM Q] on top of factory springs directly above axle. Attach to factory springs with U-bolts [ITEM S], Clamp Plates [ITEM R], 1/2" Flat Washers [ITEM T] and 1/2" Lock Nuts [ITEM U]. Securely tighten hardware. (After 300-500 miles check and re-tighten hardware as necessary.)
6. SuperSpring Install - Place the SuperSpring on top of the PSP or Mounting Kit Bracket above the OE leaf pack. For PSP installations, position the lockdown assembly so that the base of the u-bolt is placed between the front and center bumps on top of the PSP-7 mounting pad.
 7. Shackle Attachment - **Note:** The top/spring eye shackle bolts are factory pre-torqued; no adjustment/further tightening is needed. If any are loosened by the installer then retorque to 30 ft. lbs.

Part Number: SSA16

Product Line: SUPERSPRINGS

Page 3

SuperSprings International, Inc.
505 Maple Avenue
Carpenteria, CA 93013

Installation Support
+1 (800) 898-0705
support@supersprings.com

superspringsint.com

SAFETY NOTICE: We recommend installation be done by a professional or persons with sound mechanical knowledge.

WARNING: These instructions are a general guide for installation. SuperSprings International, Inc. assumes no liability for the actual installation process. Consumers and installers should apply common automotive safety practices when raising and working on any vehicle. **Do not put yourself in a position where, if the vehicle were to move unexpectedly, you may be injured.** SuperSprings' products are designed to improve vehicle ride quality. Do not load any vehicle beyond the manufacturer's specifications.

Never exceed the manufacturer's Gross Vehicle Rating (GVWR) located on your vehicles identification tag.

BEFORE INSTALLATION: Ensure the vehicle is on a level surface, the parking brake is ON, with the ignition OFF, and place blocks in front of and behind the front tires to prevent the vehicle from moving.

DURING AND/OR AFTER INSTALLATION: Ensure emergency brake cables are not touching the SuperSprings. Secure any cables out of the way with zip ties or by re-routing. Ensure all A/C lines, brake cables, and frame are clear of contact or interference.

REV. 2.0 | MAY 2022

PART NUMBER

SSA16



IMPORTANT NOTICE: Your part may have been loosely preassembled to show the final product as it will be once installed on your vehicle. Please disassemble the product before proceeding to the installation.

INSTALLATION

8. Shackle Attachment Front - Rotate the front shackles legs down on both sides of the leaf spring. Using ITL-1 or other high capacity clamp(s), compress the SuperSprings and factory leaf pack together. Place the Sleeve [ITEM F] and the Roller [ITEM G] between the Shackles and align with desired preload holes. Secure with 3/4-10 x 4 1/2" Hex bolt [ITEM L] and 3/4-10 Top Lock Nut [ITEM O]. Torque to 35 ft. lbs.

9. Shackle Attachment Rear – Rotate the rear shackles legs down on both sides of the leaf spring. Using ITL-1 or other high capacity clamp(s), compress the SuperSprings and factory leaf pack together. Place the Sleeve [ITEM F] and the Roller [ITEM G] between the Shackles and align with desired preload holes. Secure with 3/4-10 x 5" Hex bolt [ITEM M] and 3/4-10 Lock Nut [ITEM N]. Torque to 35 ft. lbs.

10. Adjust spring location front to back so that the Rollers have minimum 1/2" of clearance from spring clamps or the end of the next shorter leaf. Also confirm that there is adequate clearance around the SuperSpring from the frame, brake lines, harnesses, etc. In some cases, it may be necessary to bend routing brackets to adjust position of the brake lines or harnesses for clearance.

11. Secure Lock-down Hardware –

PSP Install - Tighten flange nuts [ITEM E] evenly and securely. Do not over tighten or distort plate shape to excess.
OR

MTKT or MXKT Install – Install the hold down clamp to secure the SuperSpring to the Mounting Kit Bracket. Position one Spring Clamp Plate [ITEM V] above the SuperSpring, and one below the Mounting Kit Bracket. Attach the Clamp Plates together with 5/16" Bolt [ITEM Y], Washer [ITEM X], and Lock Nuts [ITEM W] on each side and fasten securely.

12. Repeat steps 3 through 11 on the other side of the vehicle.

13. Lower the vehicle – elevate chassis, remove the jack stands, lower to the ground. Remove wheel chocks from front wheels.

14. Final Check – Check the position of the SuperSprings ensuring for correct hardware application and orientation. Observe all hardware ensuring for static and dynamic interference clearances. Recheck all hardware to ensure it is securely tightened. **NOTE:** After 200-500 miles of driving, recheck all hardware again for tightness.

15. Register the warranty for your SuperSprings International part. A warranty card can be found in the box your part came in.

Part Number: SSA16		Product Line: SUPERSPRINGS		Page 4
<p>SuperSprings International, Inc. 505 Maple Avenue Carpenteria, CA 93013</p> <p>Installation Support +1 (800) 898-0705 support@supersprings.com</p> <p>superspringsint.com</p>	<p>SAFETY NOTICE: We recommend installation be done by a professional or persons with sound mechanical knowledge.</p> <p>WARNING: These instructions are a general guide for installation. SuperSprings International, Inc. assumes no liability for the actual installation process. Consumers and installers should apply common automotive safety practices when raising and working on any vehicle. Do not put yourself in a position where, if the vehicle were to move unexpectedly, you may be injured. SuperSprings' products are designed to improve vehicle ride quality. Do not load any vehicle beyond the manufacturer's specifications.</p>		<p>Never exceed the manufacturer's Gross Vehicle Rating (GVWR) located on your vehicles identification tag.</p> <p>BEFORE INSTALLATION: Ensure the vehicle is on a level surface, the parking brake is ON, with the ignition OFF, and place blocks in front of and behind the front tires to prevent the vehicle from moving.</p> <p>DURING AND/OR AFTER INSTALLATION: Ensure emergency brake cables are not touch-ing the SuperSprings. Secure any cables out of the way with zip ties or by re-routing. Ensure all A/C lines, brake cables, and frame are clear of contact or interference.</p>	
			REV. 2.0 MAY 2022	