

PART NUMBER
SSA49



BEFORE YOU BEGIN

TOOLS REQUIRED

- > Floor Jack
- > Safety Jack Stands
- > Wheel Chocks
- > 1-1/16" Wrench/Socket
- > 1-1/8" Wrench/Socket
- > 9/16" Wrench/Socket
- > Heavy Duty Clamps or SuperSprings Installation Tool

PARTS LIST

Item	Part #	Discription	QTY
A	102049	SSA49 SuperSpring	2
B	112160	Polyurethane Bushing	8
C	112185	Clamp Bracket	2
D	112183	Lock Down U-Bolt	2
E	512302	3/8-16 Locking Flange Nut	4
F	PSP-7	Polyurethane Spring Pad	2
G	112142	Steel Sleeve	4
H	112159	Steel Roller	4
I	122406	Shackle Leg 3 Holes	8
J	112146	3/4" Nylon Flat Washer	8
K	112143	3/4-10 x 5" Hex Bolt Grade 8	8
L	112145	3/4-10 Nylock Nut Grade 8	8

PRIMARY APPLICATIONS

- > Ford F-350 Super Duty 4 X 2 (2017 - present)
- > Ford F-350 Super Duty 4 X 4 (2017 - present)

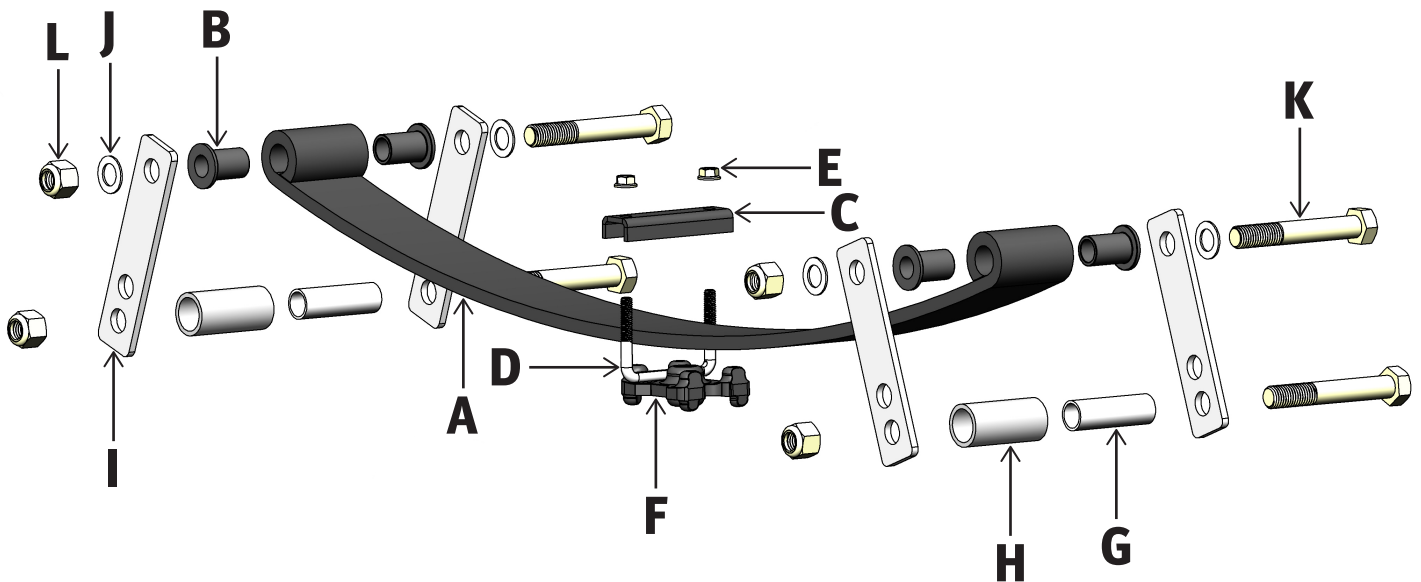

Part Number: SSA49

Product Line: SUPERSPRINGS

Page 1

SuperSprings
International, Inc.
505 Maple Avenue
Carpinteria, CA 93013

Installation Support
+1 (800) 898-0705
support@superspringsint.com

superspringsint.com

SAFETY NOTICE: We recommend installation be done by a professional or persons with sound mechanical knowledge.

WARNING: These instructions are a general guide for installation. SuperSprings International, Inc. assumes no liability for the actual installation process. Consumers and installers should apply common automotive safety practices when raising and working on any vehicle. **Do not put yourself in a position where, if the vehicle were to move unexpectedly, you may be injured.** SuperSprings' products are designed to improve vehicle ride quality. Do not load any vehicle beyond the manufacturer's specifications.

Never exceed the manufacturer's Gross Vehicle Rating (GVWR) located on your vehicles identification tag.

BEFORE INSTALLATION: Ensure the vehicle is on a level surface, the parking brake is ON, with the ignition OFF, and place blocks in front of and behind the front tires to prevent the vehicle from moving.

DURING AND/OR AFTER INSTALLATION: Ensure emergency brake cables are not touch-ing the SuperSprings. Secure any cables out of the way with zip ties or by re-routing. Ensure all A/C lines, brake cables, and frame are clear of contact or interference.

REV. 2.0 | OCT 2022

PART NUMBER

SSA49



INSTALLATION

1. Positioning the vehicle – Vehicle must be on level solid surface. Ensure emergency brake is ON and Ignition is OFF. Chock both front and rear of the front tires to prevent the vehicle from moving.
2. Jack up vehicle – elevate and support the frame securing with jack stands so that the axle is hanging with tires slightly off the ground. Wheel removal is suggested ONLY where bodies are mounted.
3. The SSA49 does not have a dedicated front and rear. However, the threaded ends of the spring eye and roller bolts should be pointing outboard, away from the frame.
4. Remove Shackle Roller Assemblies – Using 1-1/16" and 1-1/8" tools, wrenches / sockets / ratchet, remove and set aside the bolts [ITEM K] and nuts [ITEM L] retaining the Rollers [ITEM H] and Sleeves [ITEM G] from the front and rear of the shackles. Rotate the Shackles [ITEM I] toward the center and parallel to the spring.
5. PSP Install – Place PSP-7 [ITEM F] on top of the factory spring-plate, centered between the u-bolts. The PSP-7 is universal fit so whatever side fits better to the spring plate should face down.
6. Per the diagram, place the Lock Down U-Bolt [ITEM D] around the SuperSpring so the threads are facing up. Install the Clamping Plate [ITEM C] onto the u-bolt with the open side down and center on spring blade as shown. Using 9/16" wrenches / socket / ratchet, install the 3/8 flange nuts [ITEM E] onto the u-bolt [ITEM D]. Only partially tighten the nuts so that the clamp assembly can still be moved freely on the spring blade.
7. Place the SuperSpring on top of the PSP [ITEM F] above the OE leaf pack. Position the lockdown assembly so that the base of the u-bolt is placed between the front and middle bumps of the PSP-7 mounting pad. Ensure that threaded ends of the eye bolts are facing outboard, away from the frame.
8. Shackle Attachment – Note: The top/spring eye shackle bolts are factory pre-torqued; no adjustment or further tightening is needed. If any are loosened by the installer then retorque to 30 ft. lbs.

Shackle Attachment Front – Rotate the front shackles legs down on both sides of the leaf spring. Using ITL-1 or other high capacity clamp(s), compress the SuperSprings and factory leaf pack together. Place the Sleeve [ITEM G] and the Roller [ITEM H] between the Shackles and align with desired preload holes. Secure with 3/4-10 x 5" Hex Bolt [ITEM K] and 3/4-10 Lock Nut [ITEM L]. Torque to 35 ft. lbs. Ensure there is clearance on all sides of the shackle.

Part Number: SSA49		Product Line: SUPERSPRINGS		Page 2
<p>SuperSprings International, Inc. 505 Maple Avenue Carpinteria, CA 93013</p> <p>Installation Support +1 (800) 898-0705 support@superspringsint.com</p> <p>superspringsint.com</p>	<p>SAFETY NOTICE: We recommend installation be done by a professional or persons with sound mechanical knowledge.</p> <p>WARNING: These instructions are a general guide for installation. SuperSprings International, Inc. assumes no liability for the actual installation process. Consumers and installers should apply common automotive safety practices when raising and working on any vehicle. Do not put yourself in a position where, if the vehicle were to move unexpectedly, you may be injured. SuperSprings' products are designed to improve vehicle ride quality. Do not load any vehicle beyond the manufacturer's specifications.</p>		<p>Never exceed the manufacturer's Gross Vehicle Rating (GVWR) located on your vehicles identification tag.</p> <p>BEFORE INSTALLATION: Ensure the vehicle is on a level surface, the parking brake is ON, with the ignition OFF, and place blocks in front of and behind the front tires to prevent the vehicle from moving.</p> <p>DURING AND/OR AFTER INSTALLATION: Ensure emergency brake cables are not touch-ing the SuperSprings. Secure any cables out of the way with zip ties or by re-routing. Ensure all A/C lines, brake cables, and frame are clear of contact or interference.</p>	
	REV. 2.0 OCT 2022			

PART NUMBER
SSA49



INSTALLATION

Shackle Attachment Rear – Rotate the rear shackles legs down on both sides of the leaf spring. Using ITL-1 or other high capacity clamp(s), compress the SuperSprings and factory leaf pack together. Place the Sleeve [ITEM G] and the Roller [ITEM H] between the Shackles and align with desired preload holes. Secure with ¾-10 x 5" Hex Bolt [ITEM K] and ¾-10 Lock Nut [ITEM L]. Torque to 35 ft. lbs.

9. Adjust spring location front to back so that the Rollers have minimum ½" of clearance from spring clamps or the end of the next shorter leaf. Also confirm that there is adequate clearance around the SuperSpring from the frame, brake lines, harnesses, etc. In some cases, it may be necessary to bend routing brackets to adjust position of the brake lines or harnesses for clearance.

10. Secure Lock-down Hardware – Tighten flange nuts [ITEM E] evenly and securely. Do not over tighten or distort plate shape to excess.

11. Repeat steps 3 through 10 on passenger side.

12. Lower the vehicle – elevate chassis, remove the jack stands, lower to the ground. Remove wheel chocks from front wheels.

13. Final Check – Check the position of the SuperSprings ensuring for correct hardware application and orientation. Observe all hardware ensuring for static and dynamic interference clearances. Recheck all hardware to ensure it is securely tightened.

14. Register the warranty for your SuperSprings International part. A warranty card can be found in the box your part came in.

NOTE: After 200-500 miles of driving, recheck all hardware again for tightness.

Part Number: SSA49		Product Line: SUPERSPRINGS	Page 3
<p>SuperSprings International, Inc. 505 Maple Avenue Carpinteria, CA 93013</p> <p>Installation Support +1 (800) 898-0705 support@superspringsint.com</p> <p>superspringsint.com</p>	<p>SAFETY NOTICE: We recommend installation be done by a professional or persons with sound mechanical knowledge.</p> <p>WARNING: These instructions are a general guide for installation. SuperSprings International, Inc. assumes no liability for the actual installation process. Consumers and installers should apply common automotive safety practices when raising and working on any vehicle. Do not put yourself in a position where, if the vehicle were to move unexpectedly, you may be injured. SuperSprings' products are designed to improve vehicle ride quality. Do not load any vehicle beyond the manufacturer's specifications.</p>	<p>Never exceed the manufacturer's Gross Vehicle Rating (GVWR) located on your vehicles identification tag.</p> <p>BEFORE INSTALLATION: Ensure the vehicle is on a level surface, the parking brake is ON, with the ignition OFF, and place blocks in front of and behind the front tires to prevent the vehicle from moving.</p> <p>DURING AND/OR AFTER INSTALLATION: Ensure emergency brake cables are not touch-ing the SuperSprings. Secure any cables out of the way with zip ties or by re-routing. Ensure all A/C lines, brake cables, and frame are clear of contact or interference.</p>	<p>REV. 2.0 OCT 2022</p>