

PART NUMBER

SSR-307-40/47



SCAN HERE: To watch a video of this installation



BEFORE YOU BEGIN

PRIMARY APPLICATIONS

- > Dodge RAM 1500 4 X 2 (2009 - 2010)
- > Dodge RAM 1500 4 X 4 (2009 - 2010)
- > RAM 1500 4 X 2 (2011 - present)
- > RAM 1500 4 X 4 (2011 - present)

TOOLS REQUIRED

- > Floor Jack
- > Jack Stands
- > Wheel Chocks
- > 9/16 Wrench/Sockets
- > 5mm Allen Wrench

PARTS LIST

Item	Part #	Description	QTY
A	511440-38	SumoSprings Blue -40	2
	511421-38	SumoSprings Black -47	
B	512053	Mounting Bracket	2
C	512052	Clamping Bracket	4
D	512207	3/8-16 x 3/4" Flange Bolt	2
E	512244	5/16 Flat Washer	16
F	112208	5/16 Lock Nut	16
G	512274	3/8-16 x 1 3/4" Flange Bolt	2
H	512117	1" Spacer	2

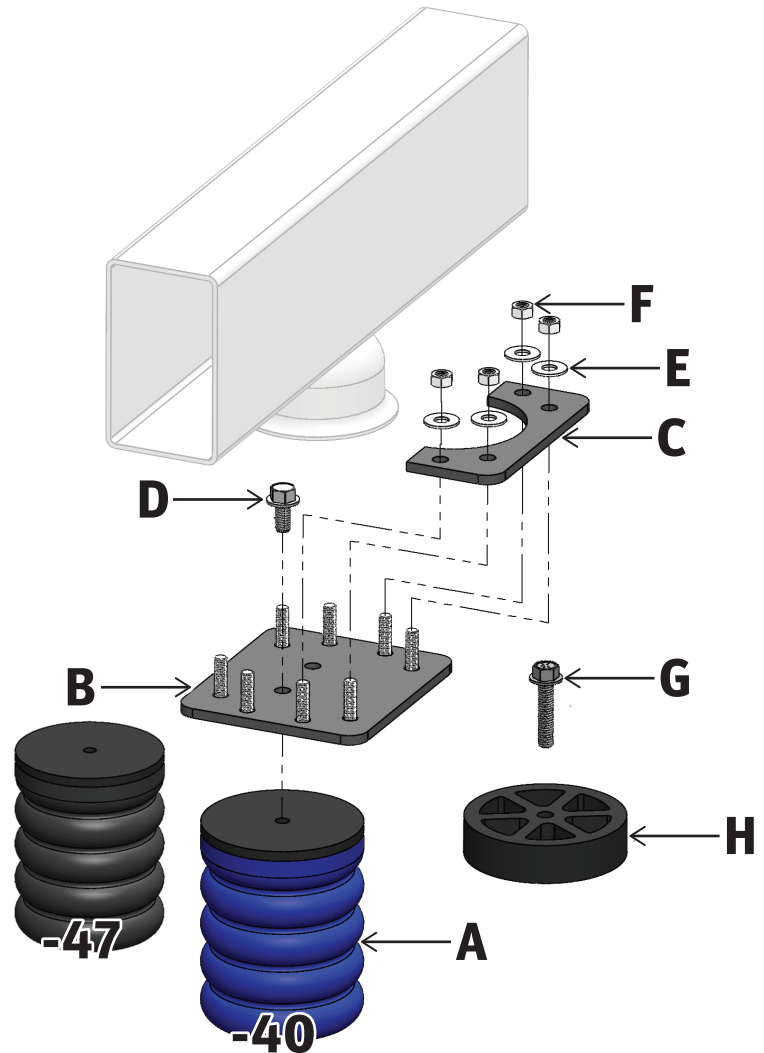

DRIVER SIDE (PASSENGER SIDE SIMILAR)

Part Number: SSR-307-40/47

Product Line: SUMOSPRINGS REAR

Page 1

SuperSprings International, Inc.
505 Maple Avenue
Carpenteria, CA 93013

Installation Support
+1 (800) 898-0705
support@supersprings.com

superspringsint.com

SAFETY NOTICE: We recommend installation be done by a professional or persons with sound mechanical knowledge.

WARNING: These instructions are a general guide for installation. SuperSprings International, Inc. assumes no liability for the actual installation process. Consumers and installers should apply common automotive safety practices when raising and working on any vehicle. **Do not put yourself in a position where, if the vehicle were to move unexpectedly, you may be injured.** SuperSprings' products are designed to improve vehicle ride quality. Do not load any vehicle beyond the manufacturer's specifications.

Never exceed the manufacturer's Gross Vehicle Rating (GVWR) located on your vehicles identification tag.

BEFORE INSTALLATION: Ensure the vehicle is on a level surface, the parking brake is ON, with the ignition OFF, and place blocks in front of and behind the front tires to prevent the vehicle from moving.

DURING AND/OR AFTER INSTALLATION: Ensure emergency brake cables are not touching the SuperSprings. Secure any cables out of the way with zip ties or by re-routing. Ensure all A/C lines, brake cables, and frame are clear of contact or interference.

REV. 1.06 | APR 2022

PART NUMBER

SSR-307-40/47



IMPORTANT NOTICE: Your part may have been loosely preassembled to show the final product as it will be once installed on your vehicle. Please disassemble the product before proceeding to the installation.

INSTALLATION

1. Park the vehicle on a hard, level surface and engage the emergency brake. Place chocks in front and behind the wheels to prevent rolling. Observe all safety precautions and wear safety glasses.
2. Raise the front of the vehicle allowing the axle to hang freely and rest the frame on the safety jack stands rated for the weight of the vehicle.
3. Remove the factory Bump Stops from the underside of the frame by twisting or prying them out of their steel cups.
4. Starting on the driver side assemble the SumoSPring [ITEM A] to the Mounting Bracket [ITEM B] utilizing the 3/8-16 x 3/4" Flange Bolt [ITEM D]. Use the hole that positions it furthest to the rear of the truck and closest to the wheel as seen in the diagram. This will center it over the contact pad on the axle.
5. Attach the two Clamping Bracket [ITEM C] to the Mounting Bracket ensuring a firm grip onto the factory Bump Stop cup using eight 5/16 Flat Washers [ITEM E] and eight 5/16 Lock Nuts [ITEM F]. Prior to tightening the eight Lock Nuts, ensure that the top bracket assembly aligns well with the contact pad on the axle.

6. Repeat steps 3 through 5 on the passenger side of the vehicle.

NOTE: If more preload is desired, install the 1" Spacer [ITEM H] between the SumoSPring and the Mounting Bracket using the 3/8-16 x 1 3/4" Flange Bolt [ITEM G].

7. If rear wheels were removed you can now reinstall the rear wheels.

8. Raise the vehicle, remove safety jack stands, carefully lower vehicle to the hard surface. Remove the chocks in the front and back of the rear wheels and release the emergency brake.

9. Register the warranty for your SuperSprings International part. A warranty card can be found in the box your part came in.

Part Number: SSR-307-40/47

Product Line: SUMOSPRINGS REAR

Page 2

SuperSprings International, Inc.
505 Maple Avenue
Carpenteria, CA 93013

Installation Support
+1 (800) 898-0705
support@supersprings.com

superspringsint.com

SAFETY NOTICE: We recommend installation be done by a professional or persons with sound mechanical knowledge.

WARNING: These instructions are a general guide for installation. SuperSprings International, Inc. assumes no liability for the actual installation process. Consumers and installers should apply common automotive safety practices when raising and working on any vehicle. **Do not put yourself in a position where, if the vehicle were to move unexpectedly, you may be injured.** SuperSprings' products are designed to improve vehicle ride quality. Do not load any vehicle beyond the manufacturer's specifications.

Never exceed the manufacturer's Gross Vehicle Rating (GVWR) located on your vehicles identification tag.

BEFORE INSTALLATION: Ensure the vehicle is on a level surface, the parking brake is ON, with the ignition OFF, and place blocks in front of and behind the front tires to prevent the vehicle from moving.

DURING AND/OR AFTER INSTALLATION: Ensure emergency brake cables are not touch-ing the SuperSprings. Secure any cables out of the way with zip ties or by re-routing. Ensure all A/C lines, brake cables, and frame are clear of contact or interference.

REV. 1.06 | APR 2022