

PART NUMBER

SSR-343-40-2/47-2



SCAN HERE: To watch a video of this installation



BEFORE YOU BEGIN

PRIMARY APPLICATIONS

- > Mercedes-Benz Sprinter 3500 4 X 4 (2019 - present)

PARTS LIST

Item	Part #	Description	QTY
A	511415	SumoSprings Blue -40	2
	511412	SumoSprings Black -47	
B	512082	Upper Clamp Plate	2
C	512083	Spacer Plate	2
D	512132	Upper Mounting Bracket	2
E	512131	Lower Mounting Bracket	2
F	512021	Axle Clamp Bracket	2
G	512227	3/8 Flat Washer	4
H	512245	3/8-16 x 7/8" FHCS	6
I	512343	3/8-16 x 5" Hex Bolt	4
J	512207	3/8-16 x 3/4" Flange Bolt	2
K	512263	3/8-16 x 3/4" Set Screw	2
L	512078	Heat Shield (Passenger Only)	1

TOOLS REQUIRED

- > Floor Jack
- > Jack Stands
- > Wheel Chocks
- > 9/16" Wrench
- > 9/16" Socket Wrench
- > 7/32" Allen key
- > T50 Torx Key

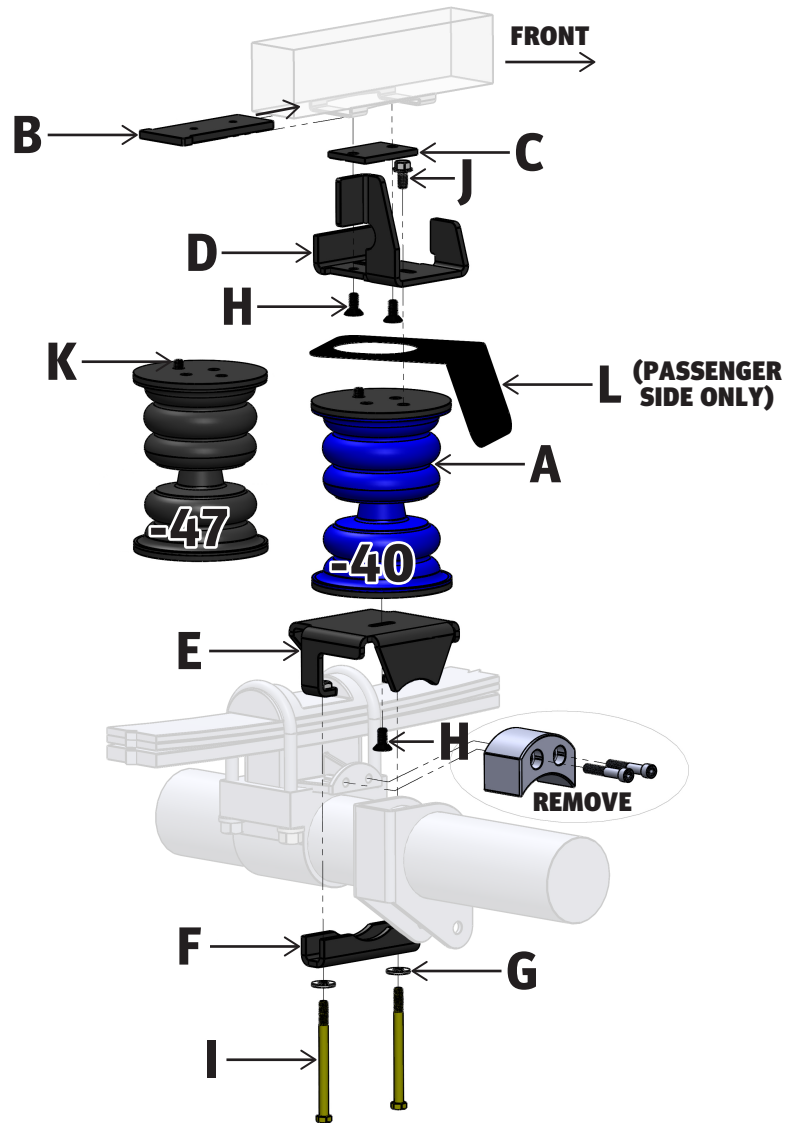

DRIVER SIDE (PASSENGER SIDE SIMILAR)

Part Number: SSR-343-40-2/47-2

Product Line: SUMOSPRINGS REAR

Page 1

SuperSprings International, Inc.
505 Maple Avenue
Carpenteria, CA 93013

Installation Support
+1 (800) 898-0705
support@supersprings.com

superspringsint.com

SAFETY NOTICE: We recommend installation be done by a professional or persons with sound mechanical knowledge.

WARNING: These instructions are a general guide for installation. SuperSprings International, Inc. assumes no liability for the actual installation process. Consumers and installers should apply common automotive safety practices when raising and working on any vehicle. **Do not put yourself in a position where, if the vehicle were to move unexpectedly, you may be injured.** SuperSprings' products are designed to improve vehicle ride quality. Do not load any vehicle beyond the manufacturer's specifications.

Never exceed the manufacturer's Gross Vehicle Rating (GVWR) located on your vehicles identification tag.

BEFORE INSTALLATION: Ensure the vehicle is on a level surface, the parking brake is ON, with the ignition OFF, and place blocks in front of and behind the front tires to prevent the vehicle from moving.

DURING AND/OR AFTER INSTALLATION: Ensure emergency brake cables are not touching the SuperSprings. Secure any cables out of the way with zip ties or by re-routing. Ensure all A/C lines, brake cables, and frame are clear of contact or interference.

REV. 2.0 | APR 2022

PART NUMBER

SSR-343-40-2/47-2



IMPORTANT NOTICE: Your part may have been loosely preassembled to show the final product as it will be once installed on your vehicle. Please disassemble the product before proceeding to the installation.

INSTALLATION

1. Park the vehicle on a hard, level surface and engage the emergency brake. Place chocks in front and behind wheels to prevent rolling. Observe all safety precautions and wear safety glasses.
2. Raise the vehicle until the axle hangs free. Rest the frame on safety jack stands rated for the weight of the vehicle. Removal of the wheel is optional.
3. Starting on the driver side, remove the factory bump stop from the underside of the frame and set aside. These can be removed by firmly pulling sideways and rotating them out of the holders.
4. Using a T50 Torx bit, remove the two M10 bolts that hold the factory bump stop contact block to the block between the axle and leaf springs.
5. Slide the Upper Clamp Plate [ITEM B] into the bump stop holder bracket on the frame from the rear. Attach the Upper Mounting Bracket [ITEM D] and the Spacer Plate [ITEM C] to the Upper Clamp Plate [ITEM B] using two 3/8-16 x 7/8" FHCS [ITEM H]. Use the supplied Blue Thread Locker and secure tightly. Position the two vertical flanges on the Upper Mounting Bracket [ITEM D] inside the frame away from the wheel.
6. Attach the Lower Mounting Bracket [ITEM D] to the bottom half of the SumoSPring [ITEM A] using a 3/8-16 x 7/8" FHCS [ITEM H] with Blue Thread Locker applied. Leave the bolt slightly loose to allow for alignment with top half of SumoSPring.
7. Locate the wider bolt pattern on the top half of the SumoSPrings. Install the 3/8-16 x 3/4" Set Screw [ITEM K] into one of the holes so that it is sticking out 3/16 of an inch.
8. Place both halves of the SumoSPrings together and set the assembly on the driver side axle with the bottom bracket positioned as seen in the diagram.
9. Align the 3/8-16 x 3/4" Set Screw [ITEM K] with the outer hole of the Upper Mounting Bracket. Bolt the top half of the SumoSPrings assembly to the top bracket using one 3/8-16 x 3/4" Flange Bolt [ITEM J]. Align the top and bottom halves of the SumoSPring and tighten the 3/8-16 x 7/8" FHCS [ITEM H] to the bottom of the SumoSPring at this time.
10. Attach the bottom bracket assembly to the axle using the SumoSPrings Under Axle Bracket [ITEM F] two 3/8-16 x 5" Hex Bolts [ITEM I], two 3/8" Flat Washers [ITEM G]. Apply Blue Thread Locker to the bolt threads and tighten securely but take care not to over tighten and bend the bottom SumoSPrings bracket.
11. Repeat steps 3 through 10 on the passenger side of the vehicle. Be sure to install the Exhaust Heat Shield [ITEM L] between the Top Bracket and SumoSPrings and position accordingly.
12. Raise the vehicle, remove safety jack stands, and carefully lower vehicle to the hard surface. Remove the chocks in front and back of the rear wheels.
13. Register the warranty for your SuperSprings International part. A warranty card can be found in the box your part came in.

Part Number: SSR-343-40-2/47-2		Product Line: SUMOSPRINGS REAR	Page 2
<p>SuperSprings International, Inc. 505 Maple Avenue Carpenteria, CA 93013</p> <p>Installation Support +1 (800) 898-0705 support@supersprings.com</p> <p>superspringsint.com</p>	<p>SAFETY NOTICE: We recommend installation be done by a professional or persons with sound mechanical knowledge.</p> <p>WARNING: These instructions are a general guide for installation. SuperSprings International, Inc. assumes no liability for the actual installation process. Consumers and installers should apply common automotive safety practices when raising and working on any vehicle. Do not put yourself in a position where, if the vehicle were to move unexpectedly, you may be injured. SuperSprings' products are designed to improve vehicle ride quality. Do not load any vehicle beyond the manufacturer's specifications.</p>	<p>Never exceed the manufacturer's Gross Vehicle Rating (GVWR) located on your vehicles identification tag.</p> <p>BEFORE INSTALLATION: Ensure the vehicle is on a level surface, the parking brake is ON, with the ignition OFF, and place blocks in front of and behind the front tires to prevent the vehicle from moving.</p> <p>DURING AND/OR AFTER INSTALLATION: Ensure emergency brake cables are not touching the SuperSprings. Secure any cables out of the way with zip ties or by re-routing. Ensure all A/C lines, brake cables, and frame are clear of contact or interference.</p>	