

PART NUMBER

SSS-4



BEFORE YOU BEGIN

PRIMARY APPLICATIONS

- > Dodge RAM 2500 4 X 2 & 4 X 4 (2006 - 2010)
- > Dodge RAM 3500 4 X 2 & 4 X 4 (2006 - 2010)
- > Dodge RAM 4500 4 X 2 & 4 X 4 (2008 - 2010)
- > Dodge RAM 5500 4 X 2 & 4 X 4 (2008 - 2010)
- > RAM 2500 4 X 2 & 4 X 4 (2011 - 2013)
- > RAM 3500 4 X 2 & 4 X 4 (2011 - 2020)
- > RAM 4500 4 X 2 & 4 X 4 (2011 - 2020)
- > RAM 5500 4 X 2 & 4 X 4 (2011 - 2020)

PARTS LIST

Item	Part #	Discription	QTY
A	311007	Contact Pad	4
B	311008	Optional 1" Spacer	4
C	311010	Dodge/Ram Adapter	4
D	512248	3/8" Fender Washer	4
E	512323	3/8" Nylock Nut	4

TOOLS REQUIRED

- > Floor Jack
- > Jack Stands
- > Wheel Chocks
- > Standard and Metric Wrenches
- > Flathead Screwdriver

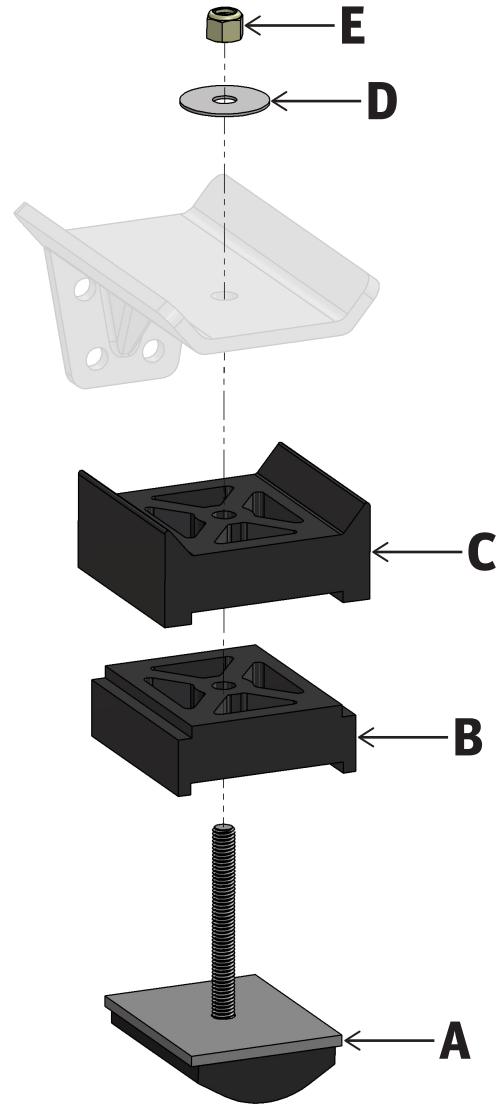

DRIVER SIDE (PASSENGER SIDE SIMILAR)

Part Number: SSS-4

Product Line: SUPERSTOPS

Page 1

SuperSprings International, Inc.
505 Maple Avenue
Carpinteria, CA 93013

Installation Support
+1 (800) 898-0705
support@superspringsint.com

superspringsint.com

SAFETY NOTICE: We recommend installation be done by a professional or persons with sound mechanical knowledge.

WARNING: These instructions are a general guide for installation. SuperSprings International (SSI) assumes no liability for the actual installation process. Consumers and installers should apply common automotive safety practices when raising and working on any vehicle. **Do not put yourself in a position where, if the vehicle were to move unexpectedly, you may be injured.** SSI's products are designed to improve vehicle ride quality. Do not load any vehicle beyond the manufacturer's specifications.

Never exceed the manufacturer's Gross Vehicle Rating (GVWR) located on your vehicles identification tag.

BEFORE INSTALLATION: Ensure the vehicle is on a hard level surface, the parking brake is ON, with the ignition OFF, and place chocks in front of and behind the tires to prevent the vehicle from moving.

DURING AND/OR AFTER INSTALLATION: Ensure emergency brake cables are not touching the SSI products. Secure any cables out of the way with zip ties or by re-routing. Ensure all A/C lines, brake cables, and frame are clear of contact or interference.

REV. 2.0 | JAN 2023

PART NUMBER
SSS-4



IMPORTANT NOTICE: Your part may have been loosely preassembled to show the final product as it will be once installed on your vehicle. Please disassemble the product before proceeding to the installation.

INSTALLATION

1. Park the vehicle on a hard, level surface and engage the emergency brake. Place chocks in front and behind wheels to prevent rolling. Observe all safety precautions and wear safety glasses.
2. Raise the vehicle to allow the axle to hang freely and support the frame using safety jack stands.
3. Raise the rear of vehicle until the factory top overload blade relaxes away from the contact perches, A gap of 4+" is plenty of room but you can compress the blade with a c-clamp if needed. Support frame using safety jack stands.
4. Starting on the driver side, remove the existing overload perch cover. Some application require unbolting them while others may require prying or cutting them off.
5. Starting with the Contact Pad [ITEM A] slide the Dodge/Ram Adapter [ITEM C] onto the stud and locate the Contact Pad into the channel of the Adapter. If you want to create more preload, insert the Optional 1" Spacer [ITEM B] between the Contact Pad [ITEM A] and the Dodge/Ram Adapter [ITEM C].
6. Insert the stud through the hole/slot in the overload perch from the bottom and center the Contact Pad over the overload leaf.
7. Install the 3/8" Fender Washer [ITEM D] and 3/8" Nylock Nut [ITEM E]. Torque to 40 ft. lbs. and make sure to seat the washer to the curve of the perch.
8. Repeat steps 4 through 7 on the passenger side of the vehicle.
9. Raise the vehicle, remove safety jack stands, and carefully lower it to the hard surface. Remove the chocks in front and back of the rear wheels.
10. Register the warranty for your SuperSprings International part. A warranty card can be found in the box your part came in.

IMPORTANT NOTE: We recommended that you road test and observe any changes in the SwayStops position. The units should remain square to the leaf blade with the washer and nut tightly in place.

Part Number: SSS-4	Product Line: SUPERSTOPS	Page 2
<p>SuperSprings International, Inc. 505 Maple Avenue Carpinteria, CA 93013</p> <p>Installation Support +1 (800) 898-0705 support@superspringsint.com</p> <p>superspringsint.com</p>	<p>SAFETY NOTICE: We recommend installation be done by a professional or persons with sound mechanical knowledge.</p> <p>WARNING: These instructions are a general guide for installation. SuperSprings International (SSI) assumes no liability for the actual installation process. Consumers and installers should apply common automotive safety practices when raising and working on any vehicle. Do not put yourself in a position where, if the vehicle were to move unexpectedly, you may be injured. SSI's products are designed to improve vehicle ride quality. Do not load any vehicle beyond the manufacturer's specifications.</p>	<p>Never exceed the manufacturer's Gross Vehicle Rating (GVWR) located on your vehicles identification tag.</p> <p>BEFORE INSTALLATION: Ensure the vehicle is on a hard level surface, the parking brake is ON, with the ignition OFF, and place chocks in front of and behind the tires to prevent the vehicle from moving.</p> <p>DURING AND/OR AFTER INSTALLATION: Ensure emergency brake cables are not touching the SSI products. Secure any cables out of the way with zip ties or by re-routing. Ensure all A/C lines, brake cables, and frame are clear of contact or interference.</p> <p>REV. 2.0 JAN 2023</p>