

Product Name: BOV Controller Kit
 Product Description: Electronic BOV controller
 Product Number: TS-0304-100X



IMPORTANT NOTES:

- Please thoroughly read and understand these instructions before commencing this installation.

RECOMMENDATIONS

- Turbosmart recommends that your BOV controller is fitted and adjusted by an appropriately qualified technician
- Turbosmart recommends that a boost gauge be permanently fitted to the vehicle

Please check that the following items have been provided in your BOV Controller Kit

Quantity	Description	Use
1	BOV Controller Unit	BOV Controller
1	Race Port assembly	Blow off valve fitted with orange inner spring and stainless steel weld flange
2m	2 core wire	Connect BOV Controller to solenoid
1	Heat shrink	Insulating soldered joints
2	Double sided adhesive	Surface mounting BOV controller
2	M3 X 30 Screws	Mounting BOV controller
2	M3 Nuts	Mounting BOV controller
1	3 Port solenoid	Controls pressure to BOV
3	1/8 NPT nipples	Connects solenoid to hose
1.2m	6.3mm Reinforced pressure tube	To connect the solenoid to the BOV
1	Solenoid Bracket	Mounting the solenoid
2	M3X20 SHCS	Mounting bracket to solenoid
2	5 amp Fuses	To protect the BOV controller and solenoid from voltage problems
1	M6 Nut	Secure solenoid bracket to car
1	M6 X 25 SHCS	Secure solenoid bracket to car
1	M6 Washer	Secure solenoid bracket to car
10	Cable ties	Securing vacuum tube and wires
1	Crimp ring terminal	For ground connection
4	Hose clamps	Securing all pressure lines
1	8 way wiring loom	Connects BOV Controller to devices and power

FUNCTIONALITY

The BOV controller works by detecting a negative voltage change in throttle position. It then energises the solenoid to vent all of the air out of the BOV cap, causing a pressure differential between the piston of the BOV and the cap which will vent pressure from the intake system. There are 2 parameters that can be adjusted to tune the controller for optimum performance; duration and sensitivity. The green LED shows that the BOV controller is on. The yellow LED shows when the solenoid is activated.

LAYOUT

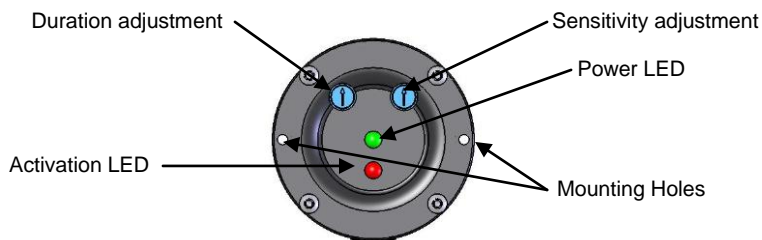

INSTALLATION

Mount the unit away from any heat source and moisture. Wire up the unit as per diagram. Do not connect the unit to a power supply which will have a greater voltage than 14V DC. **Unused wires must be insulated with electrical tape so that they do not touch other wires or the chassis**

1. ORANGE = +5V (For external TPS) – **OPTIONAL if your engine does not have a OEM TPS**
2. GREEN = 0V (For external TPS) - **OPTIONAL if your engine does not have a OEM TPS**
3. WHITE = TPS signal Input
4. YELLOW = Solenoid trigger signal
5. GREY = Disable Trigger wire (Ground to disable Controller) - **OPTIONAL**
6. BROWN = Enable Trigger wire (Ground to keep solenoid energised) - **OPTIONAL**
7. BLACK = Controller Ground
8. RED = +12V (**USE SUPPLIED 5A Fuse inline**)

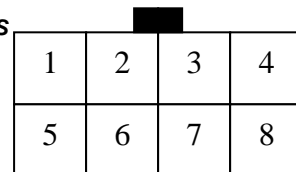

Looking into BOV Controller

SOLENOID CONNECTION

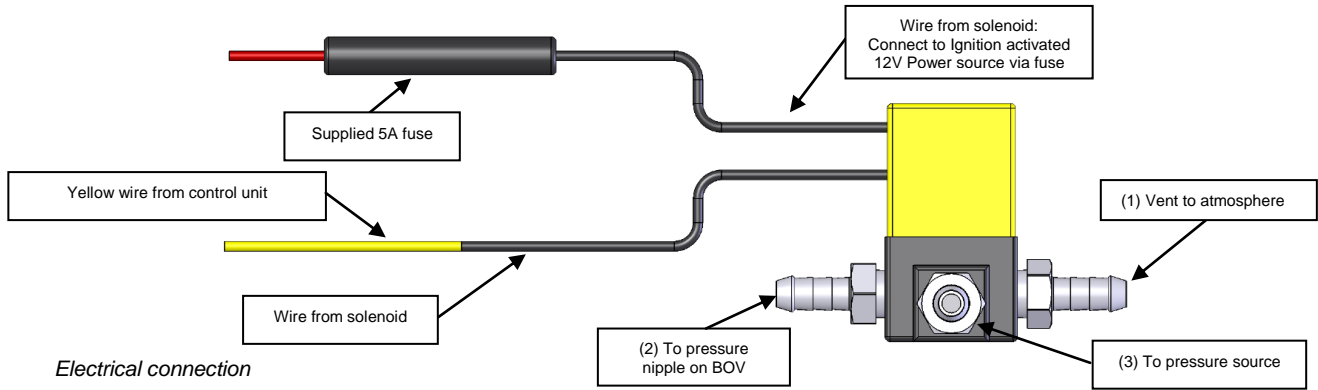

Electrical connection

Connect one wire of the solenoid to a fused (**use supplied fuse**) ignition activated 12V power source and connect the other wire to the Solenoid trigger signal (Yellow) on the BOV controller unit. Polarity is not important.

Pressure connection

Port 1: Vent to atmosphere.

Port 2: To pressure nipple of BOV.

Port 3: To pressure source e.g. Intercooler piping (Make sure the pressure source is not shared and that it is from the same part of the pipe work as the BOV)

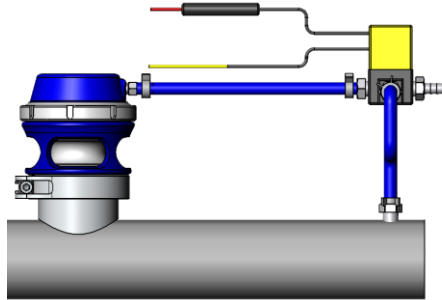

MOUNTING YOUR BOV

- Allow the engine to cool down before installing your Race Port
- Identify a suitable location along the intercooler/intake piping for the Race Port – this will need to be between the outlet of the turbo and the intake manifold ideally between the intake manifold and the intercooler
- Remove the Race port from the stainless steel weld on adapter by removing the V-Band clamp. The V-band clamp is removed by opening the screw until it has reached the end stop, then pushing the head of the screw in a “syringe” like motion and lifting the Race Port off the stainless steel weld flange.

Step 1:

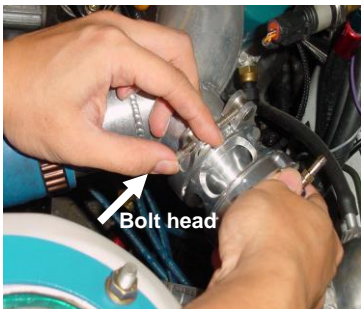

Step 2:

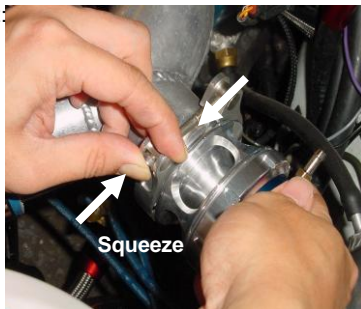

Step 3:

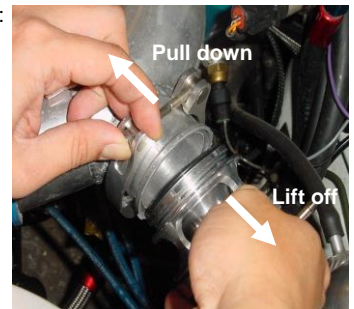

- Weld the stainless steel adapter onto the intercooler pipe in your ideal position, then allow the adapter to cool down

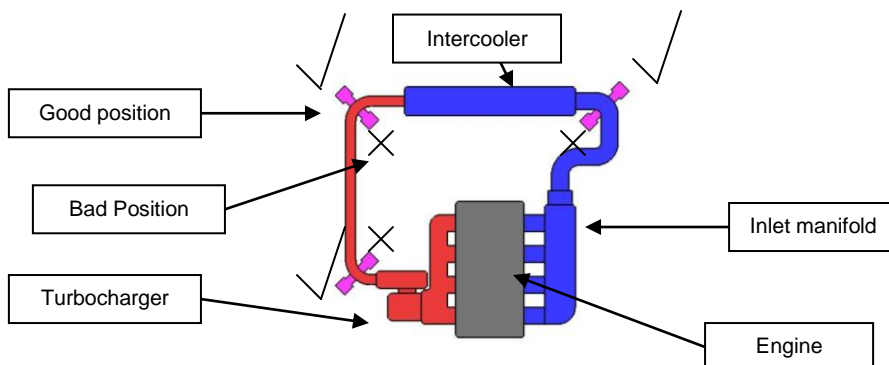

- Put the V-Band clamp over the adapter before re-installing the O-Ring seal and the Race Port
- Open the V-Band clamp and place in position. Tighten the V-Band clamp screw until it is finger tight then turn an additional 2.5 turns or 4 Nm (3 ft/lbs) with an allen key. Be sure not to over tighten the screw as this will cause damage to the V-Band clamp
- Install the provided provided nipple into one of the ports in the top cap and install the blanking plug into the other.
- Connect Port 2 of the solenoid to the pressure nipple of the Race Port BOV.
- Secure all silicone hose ends with correct clamps
- Start the engine and check for air leaks in the system

THROTTLE POSITION CONNECTION

The BOV controller can be wired to the existing throttle position sensor on your vehicle. Connect the white wire to the signal output wire from the existing throttle position sensor.

(OPTIONAL) For vehicles without a standard throttle position sensor (such as the 12V Cummins Diesel engine), an external one can be wired in. The **ORANGE AND GREEN** must be used to power the external throttle position sensor if one needs to be installed as the TPS requires a 5V power supply and not a 12V power supply.

SWITCHED INPUT CONNECTION (OPTIONAL)

If your vehicle does not have a standard throttle position sensor and you do not want to install an external throttle position sensor, a double throw switch can be used to activate the BOV. The switch needs to ground the **GREY WIRE ONLY** when the accelerator pedal is pressed in and needs to ground the **BROWN WIRE ONLY** when the accelerator pedal is released.

ADJUSTING YOUR BOV CONTROLLER

DURATION: The duration is the length of time that the solenoid blocks the pressure signal to the BOV. The longer the duration, the longer the BOV will not have pressure supplied to the cap, essentially keeping the BOV open. The controller also has an override function which reactivates the BOV once it detects positive throttle movement, independent of what the duration is set at.

SENSITIVITY: The sensitivity setting determines how the BOV controller reacts to throttle movement. The controller will only activate on negative changes in throttle. The higher the sensitivity setting, the lower the negative change in throttle movement needs to be before the solenoid will activate the BOV e.g. a change from 4V to 3.5V will not activate the valve but from 4V to 3V will activate the valve.

(OPTIONAL IF SWITCHED INPUT CONNECTION METHOD IS NOT USED) ENABLE FUNCTION: Grounding the **BROWN WIRE** activates the enable function which allows the BOV controller to keep the solenoid activated. Even though the unit is still reading changes in throttle position, it will not respond to them, not allowing pressure to reach the top of the BOV. The yellow LED will stay on when this function is activated. This function can be used to limit boost as the BOV will not have any pressure keeping it closed. It can also be used as an over boost safety feature when connected to another device such as a data logger or ECU which can ground the wire if a over boost scenario is reached.

(OPTIONAL IF SWITCHED INPUT CONNECTION METHOD IS NOT USED) DISABLE FUNCTION: Grounding the **GREY WIRE** will activate the disable function which disables the BOV controller. The BOV controller is still switched on but will not respond to changes in throttle position, keeping pressure to the top of the BOV, not allowing the BOV open. This can be used when the BOV is not required to be functional e.g. when using cruise control, the BOV will not actuate on sudden throttle changes cresting hills.

RACE PORT SPRING REPLACEMENT (OPTIONAL)

The Race Port is fitted with an orange inner spring which is suitable for most applications but additional springs can be installed to ensure the valve is closed if you are experiencing the valve opening under boost conditions.

- 1) Remove the Race Port off the intake piping
- 2) Remove any pressure nipples and port blanks in the top cap. Hold the cap down in a press or vice. Unscrew the locking collar. Slowly, back off the vice or press and remove the cap.
- 3) Select and install the required spring or combination of inner and outer springs into the piston assembly.
- 4) Ensure that the diaphragm is inside the diaphragm groove.

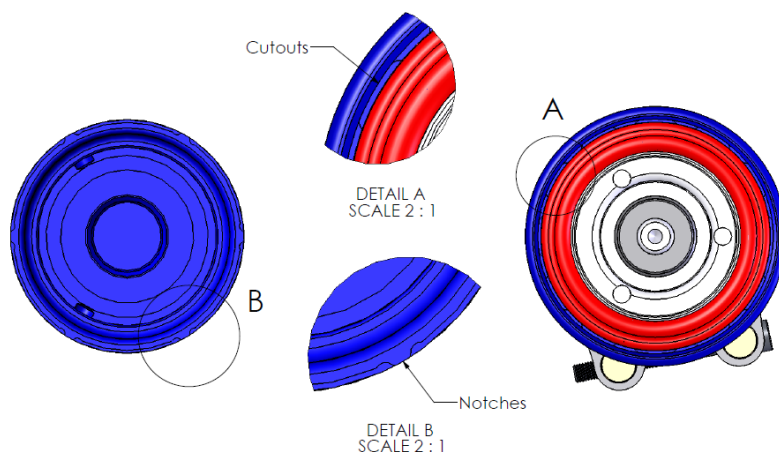

- 5) Slowly push the top cap down on the lower diaphragm housing in a vice or press. As the cap reaches the diaphragm, line up the notches in the cap (Figure 1) with the cut outs (Figure 2) in the lower diaphragm housing. Carefully push the cap down till the cap is home on the lower diaphragm housing. Reinstall the locking collar. Make sure that the cap is clamped down while tightening the collar

ONE YEAR LIMITED WARRANTY

Turbosmart is a company built on Customer Satisfaction and Service. That is why all of our products go through regimented test procedures before they are packaged and shipped. Turbosmart stands behind its products for one full year after purchase. Terms of Warranty, Service and Returns are as follows:

Limited Warranty: Turbosmart warrants its products to be free from defects in material and workmanship under normal use and if properly installed for a period of one year from date of purchase. If found to be defective, it will be replaced or repaired if returned prepaid along with proof of date of purchase. This shall constitute the sole remedy of the purchaser and the sole liability of Turbosmart to the extent permitted by law, the foregoing is exclusive and in lieu of all other warranties or representations whether expressed or implied, including any implied warranty of merchantability or fitness. In no event shall Turbosmart be liable for special or consequential damages. This warranty is only valid on products purchased from Turbosmart Authorized Dealers.

Service: After the warranty period has expired, repair service is charged based on a minimum and maximum charge rate. (Contact Customer Service for current rate).

Returns: When returning a Turbosmart product for repair, it must be accompanied by a completed Customer Warranty Form and RMA number. To access this form please go to our website www.turbosmartonline.com and you will find it on the Downloads page.

THE TURBOSMART PLEDGE

DO NOT USE ANY TURBOSMART PRODUCT UNTIL YOU HAVE CAREFULLY READ AND UNDERSTOOD THE FOLLOWING AGREEMENT. Please call if you have any questions or do not understand this agreement. Refer to our brochure, website or catalogue for terms and conditions and further information regarding your product. Turbosmart appreciates your business and pride ourselves on our customer service. We are always happy to offer you advice and will provide you with help in any way we can. The purpose of this agreement is to avoid any problems or hard feelings.

We sometimes make mistakes, as do our dealers, distributors and suppliers. Even customers can sometimes order the wrong parts. Do not use, modify, install, trial assemble, nick, drop, scratch or adjust any part until you first check for any damage. Damage must be reported immediately. NO EXCEPTIONS. If there are any components missing please contact your authorized reseller immediately upon receipt of your shipment. Missing components must be reported within five (5) business days of receipt. Parts returned for any reason MUST BE IN RESALABLE CONDITION. It is YOUR responsibility, "THE CUSTOMER" to carefully package any returns to avoid shipping damage. Insurance is highly recommended. Credit cannot be issued for damaged goods.

Warranty as to Defects – Australian Consumer Law

- 1.1 We warrant for a period of twelve (12) months from the date of supply of the Goods and/or Services that if due to the fault of Turbosmart the Goods and/or Services (as the case may be) provided by Us are defective then We will, as determined by Us do one or more of the following:
 1. In the case of Goods; the replacement of the Goods, the supply of equivalent Goods, the repair of the Goods, the payment of the cost of replacing the Goods or of acquiring equivalent Goods, or the payment of having the Goods repaired; or
 2. In the case of Services; the supplying of the Services again, or the payment of the cost of having the Services supplied again.
- 1.2 You will only be entitled to the benefit of the warranty set out in this pledge, if You have not wholly or partially caused or contributed to the defect to the Goods by the misuse of the Goods or the failure to use the Goods in accordance with any specifications or instructions applicable to the Goods.
- 1.3 The warranty contained in this pledge is provided by Turbosmart Pty Limited of 32 Milton Street North, Ashfield NSW 2131, Australia, Telephone: +(61) 1300 735 506, Email: sales@turbosmart.com.au.
- 1.4 In order for a You to make a claim on the warranty You must within twelve (12) months of delivery of the Goods or Services give written notice to Us at the address specified in clause 1.3 above of the details of any defects in respect thereof. Any Goods referred to in a notice given pursuant to this clause should be left in the state and condition in which they were delivered until such time as We or Our duly authorised agent have inspected the Goods with such inspection to be carried out within a reasonable time after service of such notice. If the Goods are not so left in the state and condition in which they were delivered then the You shall be deemed to have accepted the Goods and the warranty contained in this pledge shall not apply.
- 1.5 You shall be responsible for all expenses associated with making a warranty claim under this pledge however if the Goods and/or Services are found to be defective due to Our fault then We shall reimburse You for any expenses incurred by You in making a warranty claim upon receiving evidence satisfactory to Turbosmart to support such expenditure.
- 1.6 The benefits to You given by the warranty contained in this pledge are in addition to other rights and remedies of You have under a law in relation to the Goods or Services to which the warranty relates. In accordance with the Australian Consumer Law We makes the following statement: "Our goods come with guarantees that cannot be excluded under the Australian Consumer Law. You are entitled to a replacement or refund for a major failure and compensation for any other reasonably foreseeable loss or damage. You are also entitled to have the goods repaired or replaced if the goods fail to be of acceptable quality and the failure does not amount to a major failure."

EXCEPT AS PROVIDED BY LAW, THIS LIMITED WARRANTY IS THE ONLY EXPRESS WARRANTY, WHICH APPLIES TO TURBOSMART PRODUCT AS EXPRESSLY GIVEN IN LIEU OF ANY OTHER WARRANTY EXPRESSED OR IMPLIED, INCLUDING THAT OF MERCHANTABILITY. ANY IMPLIED WARRANTY INCLUDING THAT OF MERCHANTABILITY AND/OR FITNESS FOR A PARTICULAR PURPOSE IS HEREBY LIMITED BY THE SAME TERMS AND TIME LIMITATIONS SET FORTH IN THIS LIMITED EXPRESS WARRANTY AND OTHERWISE EXCLUDED.

EXCEPT FOR THOSE OBLIGATIONS ASSUMED HEREIN, TURBOSMART ASSUMES NO OTHER OBLIGATIONS IN CONNECTION WITH THE SALE OF ITS PRODUCTS.

IN THE EVENT THAT THE INDIVIDUAL PURCHASER DOES NOT AGREE WITH THIS AGREEMENT THE BUYER MAY PROMPTLY RETURN THIS PRODUCT, IN A NEW AND UN-USED CONDITION, WITH A DATED PROOF OF PURCHASE, TO THE PLACE OF PURCHASE WITHIN SEVEN (7) DAYS FROM THE DATE OF PURCHASE FOR A FULL REFUND.

THE INSTALLATION OF THIS PRODUCT INDICATES THAT THE INDIVIDUAL PURCHASER HAS READ AND UNDERSTOOD THIS AGREEMENT AND ACCEPTS ITS TERMS AND CONDITIONS.

Happy motoring!
The Turbosmart Team

Turbosmart Pty Limited P.O. Box 264 Croydon, NSW 2132 Australia ABN: 69 081 069 794
Ph: +61 1300 735 506 Fax: +61 1300 735 509 Email: instructions@turbosmart.com.au
www.turbosmartonline.com