



TITANIUM SIGNATURE SERIES PLUS INSTALLATION MANUAL

ALL 1/2" FUEL PORTS



APPLICATION:

TSP-D07-250G
(250GPH @ 16-18PSI)
TSP-D07-290G
(290GPH @ 16-18PSI)

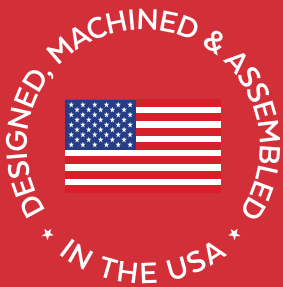

*Cummins 5.9L/6.7L
24 Valve*

*Standard Pickup Truck
2005-2018
1998.5-2004
2021-2024 (CP3)
with In-tank Lift Pump



**Note: Cab and Chassis
may require modifications**



FASS DIESEL FUEL SYSTEMS® / ENGINEERED EXCELLENCE

RAM



www.fassride.com

(866) 769.3747

Thank you for choosing FASS, from Diesel Performance Products, Inc.

FASS specializes in building extremely high-quality fuel products. We have earned an unsurpassed reputation for excellence in our industry by using only the highest-quality American-made components. In order to support our American workers and our American economy, more than 98+ percent of our products are manufactured completely in the United States.

Of course, that dedication to excellence comes at a price, but it is important to remember that price does not dictate quality-quality dictates price! We will never compromise by using cheaper, foreign-made components, like so many of our competitors do.

Customer satisfaction is our top priority and we strive always to provide outstanding customer service. Our Research and Development department, in conjunction with our Dealer Support Department, continually searches for ways to improve quality, expand our product line, and provide superb support. Our exclusive ViP Network ensures that customers receive the proper products and support at the local level. The extended lifetime warranty is only available on products purchased from the network. There is no warranty on products not purchased outside the network.

IMPORTANT:

In order to qualify for the lifetime extended warranty, your product registration form and proof of purchase from an authorized dealer must be submitted to FASS Fuel Systems within 30 days of purchase. Failure to comply will void the warranty. We have the right to deny any warranty believed to be false, altered or purchased through an unauthorized or terminated dealer. A current list of authorized dealers can be found on our website, FASSRide.com.

The complete conditions of the Limitation of Warranty can be found in the back of this manual, and FASSRide.com.

**For more information,
contact Technical Support:
Diesel Performance Products, Inc.
16234 State Hwy O Marthasville,
MO 63357
636-433-5410**



WARNING!

This product has NO WARRANTY unless:

- 1. It has been purchased from an **Authorized** or **ViP FASS Dealer**. If in doubt, check www.FASSRide.com.**
 - 2. It is registered within thirty (30) days of purchase.**
- Other conditions may apply. Please see full warranty information.**

***NOTE:* Warranty is **void** if product was purchased below FASS website advertised pricing.**

ATTENTION!

Before you begin installation

Register for your Warranty ONLINE at

<https://www.fassride.com/register-a-warranty/>

No online access, call our TECH Support at

1-866-769-3747

FOLLOW THESE STEPS TO ENSURE A SIMPLE, CORRECT INSTALLATION OF YOUR NEW TITANIUM FUEL SYSTEM

ATTENTION:

Be sure to identify the proper FASS System and fuel line configuration. For help, our product finder can be found at www.FASSride.com. Follow the instructions to see fuel line detail.

- 1** Be sure the serial number on this installation manual matches that on the outside of the box.
- 2** Pay close attention to ALL WARNINGS
- 3** Read all instructions before starting installation of this product.
- 4** Inventory the package components. Notify the place of purchase immediately of any parts missing or damaged.
- 5** The installation recommendations contained herein are guidelines. Use good judgment and take into consideration your vehicles' accessories.
- 6** For best results in accuracy and efficiency (due to training, communication, and our relationship with our dealer network), we recommend a VIP FASS dealer for the installation. They are prepared to install the FASS fuel pumps with the most efficiency. If a situation or problem arises during the installation, the dealer is prepared to handle it. Diesel Performance Products, Inc. is not responsible for any installation mistakes.
- 7** If you have any questions or concerns that cannot be addressed with your dealer, email or call FASS.

**If any installation procedure is uncertain, contact FASS technical support.
Call customer service at 636-433-5410,
or send us an e-mail: techsupport@FASSride.com
with the following information:**

Your name, address and daytime phone number
Model(**TSP-DO7-250G**) or (**TSP-DO7-290G**)
Serial Number
Last 6 digits of vehicles' VIN

Date of purchase
Nature of Your Concern
Serial number



INSTALLATION MANUAL

TSP-D07-250G or TS-PD07-290G

(Installation Videos are available at www.fassride.com)

Recommended Application

TSP-D07-250G: Cummins 2005-2018 & 2021-2024 with 1,000 - 1,200 horsepower

TSP-D07-290G: Cummins 2005-2018 & 2021-2024 with 1,200 - 1,500 horsepower

NOTE: THIS KIT MAY ALSO BE USED ON 1998.5-2004 CUMMINS WITH IN TANK LIFT PUMP MODIFICATIONS

1. Read all instructions before starting installation of this product!
2. Installing the improper FASS Pump can cause severe engine damage.
3. Secure vehicle from ROLLING!
4. Cab and Chassis may require modifications
5. Consult vehicle's manufacturers' instructions concerning the electrical system before attempting any electrical connections.
6. Be sure that the serial # on this installation manual matches that of the outside of the box.
7. Flush and clean all brass fittings and fuel line from debris.
8. Keep debris from entering the internals of the system during installation. Getting debris in the water separator nipple can lock up the motor. If the motor does lock up from debris call FASS for technical assistance.

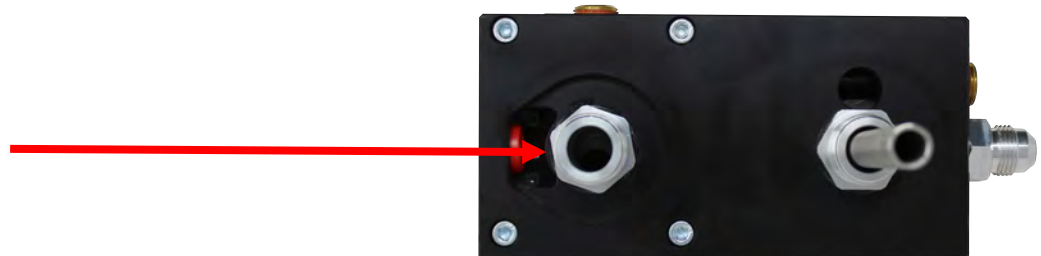

9. Wear safety glasses when operating power tools such as drills and grinders or when using a punch or chisel.
10. Properly secure lines to prevent chaffing.

BEFORE STARTING THE INSTALLATION PROCESS LUBRICATE THE BED BOLT WITH WD-40 TO HELP WITH INSTALLATION



WARNING!

Always be sure to fill the fuel tank to full after a new FASS installation. Failure to do so can result in excessive sound output, or priming issues!

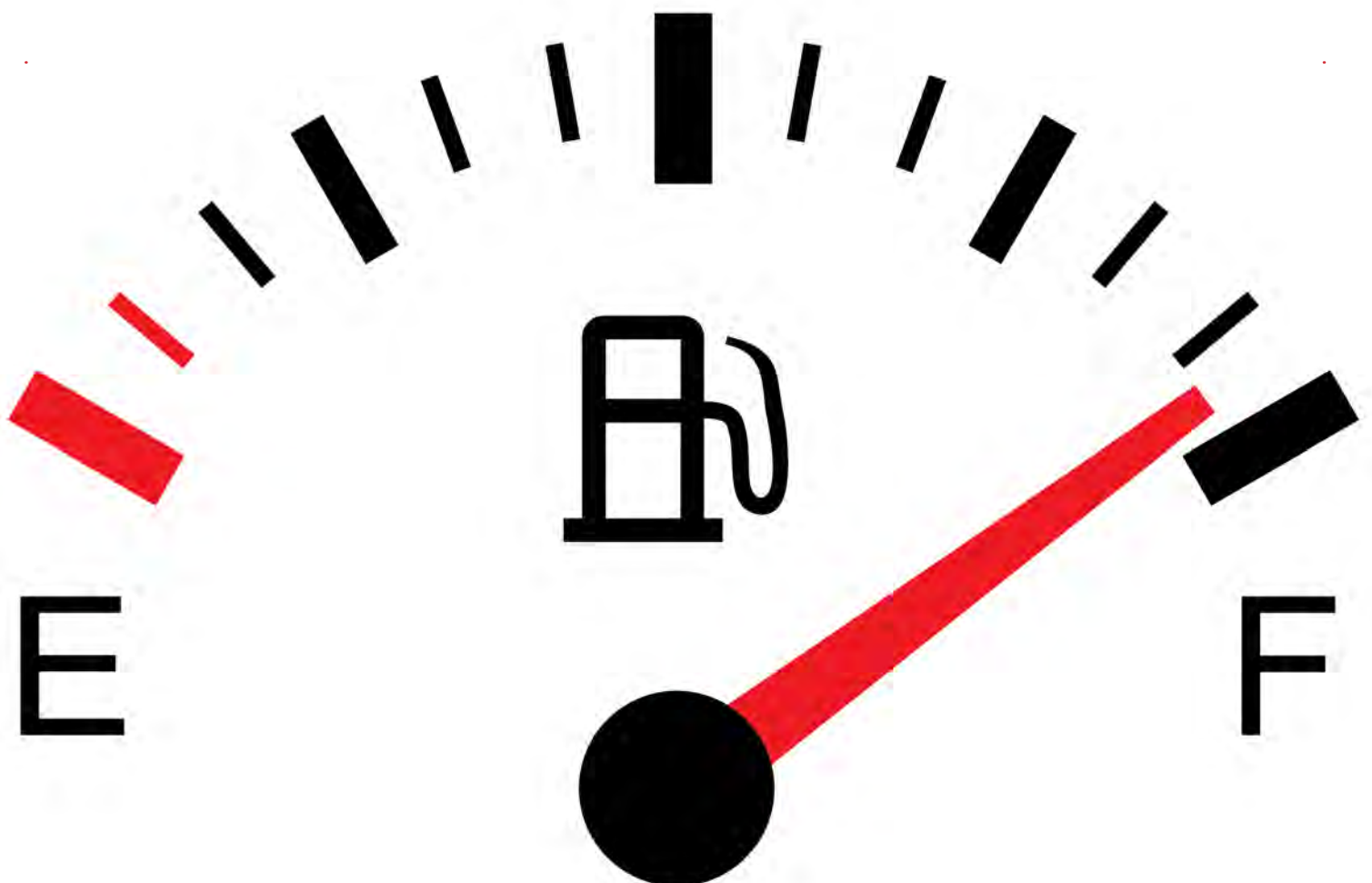

SIGNATURE SERIES PLUS

250 GPH or 290 GPH

16-18 psi (Approximately)

Rear View



Front View



PUMP GUIDE:

- 1. "E" To Engine**
- 2. "R" Return to Tank**
- 3. Serial Number**
- 4. "T" Fuel Inlet**
- 5. Electric Heater Ports**
- 6. "G" Gauge Port**

INSTALLATION GUIDE:

- Step 1. Install Electrical Harness**
- Step 2. Prep the FASS**
- Step 3. Mount the FASS**
- Step 4. Fuel Line Supply**
- Step 5. Review Installation**

SIGNATURE SERIES PLUS

250 GPH or 290 GPH

16-18 PSI (Approximately)

Note: Going over 30 PSI WILL void warranty.

***NOTE: WARRANTY MAY BEVOID IFSILICONE
BAND IS REMOVED FROM MOTOR!!***

***The silicone band is in place to retain motor wires,
preventing damage to the electric motor.***



CONTENTS

NOTE: Owner's Manual available for download on our website,
www.FASSride.com



DIELECTRIC GREASE



**TWO (2)
OR-017**



OR-030

NOTE: THESE SPARE BASE O-RINGS ARE INCLUDED WITH THE KIT IN
THE EVENT OF A PINCHED O-RING DURING ASSEMBLY



MP-TSP-9022

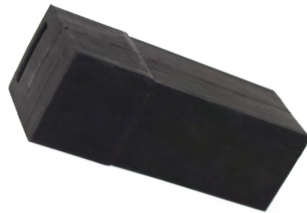

RELAY COVER



RS-2001



FL-1002-BK x15'



WH-1004-3



FL-1058-BK x3'



PBR-2001



PFB-2002

MOUNTING PACKAGE CONTENTS



THREE (3)
PL-1005-BK



TWO (2)
PL-2003-BK



AN-8-ORB-10-BK



AN-10-ORB-10-BK



BHF-1008



BHF-1010



TWO (2)
BHN-1005



TWO (2)
OR-119



TWO (2)
PL-2058-BK



M12-1.75x45MM



M12-1.75x60MM

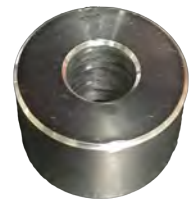

DS-1001

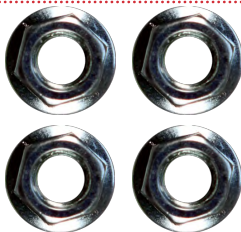

FOUR (4) LOCKING
NUT 3/8"

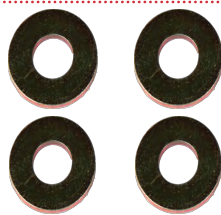

FOUR (4)
3/8" WASHERS



THREE (3)
HEX BOLT
1/4"-20x1
3/4"



FOUR (4)
Hex Bolt 3/8" -16x1 1/2"

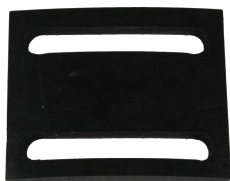

RS-2002



TWO (2)
HC-1001



THREE (3)
WA-1001D



CABLE TIES

MOUNTING PACKAGE CONTENTS



**TWO (2)
RING TERMINAL**



**5/16" VITON
FL-1006**



1/2" WASHERS



ST-1005P



DIPF-1003



**5/8" VITON
FL-1007**

STEP 1: **INSTALLING ELECTRICAL HARNESS**

A. Using the supplied dielectric grease, apply a small amount to the relay pig tail and the fuse holder.



STEP 1: **INSTALLING ELECTRICAL HARNESS**

B. Once applied, install the supplied relay into the relay pig tail and the 30 amp fuse into the fuse holder.



STEP 1: **INSTALLING ELECTRICAL HARNESS**

C. With the relay and 10 amp fuse installed, install the relay cover and fuse holder cover.



STEP 1:

INSTALLING ELECTRICAL HARNESS

D. Crimp the supplied ring terminals to the red and green wires of the WH-1004-3. Attach the red wire to the positive terminal of the battery and the green wire to the negative terminal of the battery.

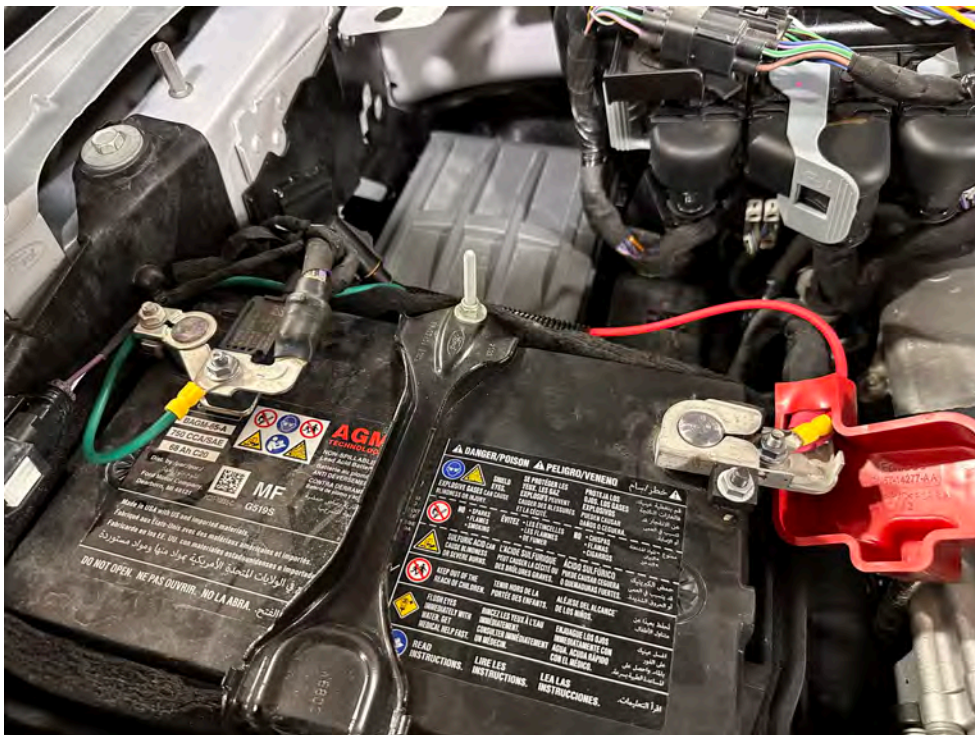
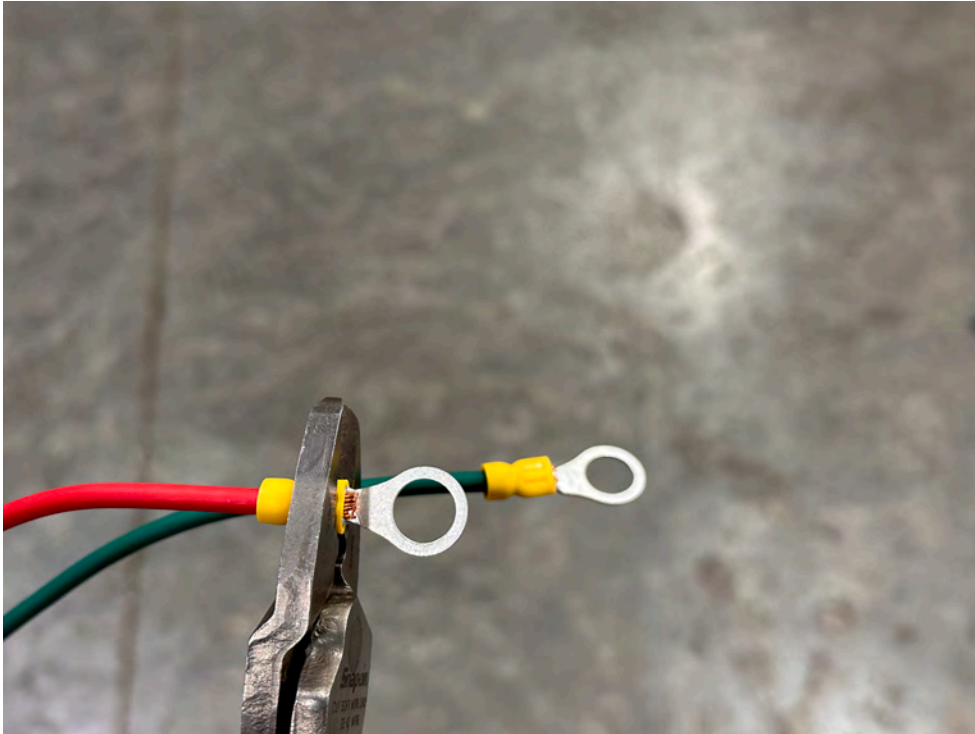

STEP 1: **INSTALL ELECTRICAL HARNESS**

E. Secure relay and fuse in an upright position, as shown, to prevent moisture from entering. Di-electric grease may be applied to prevent corrosion.

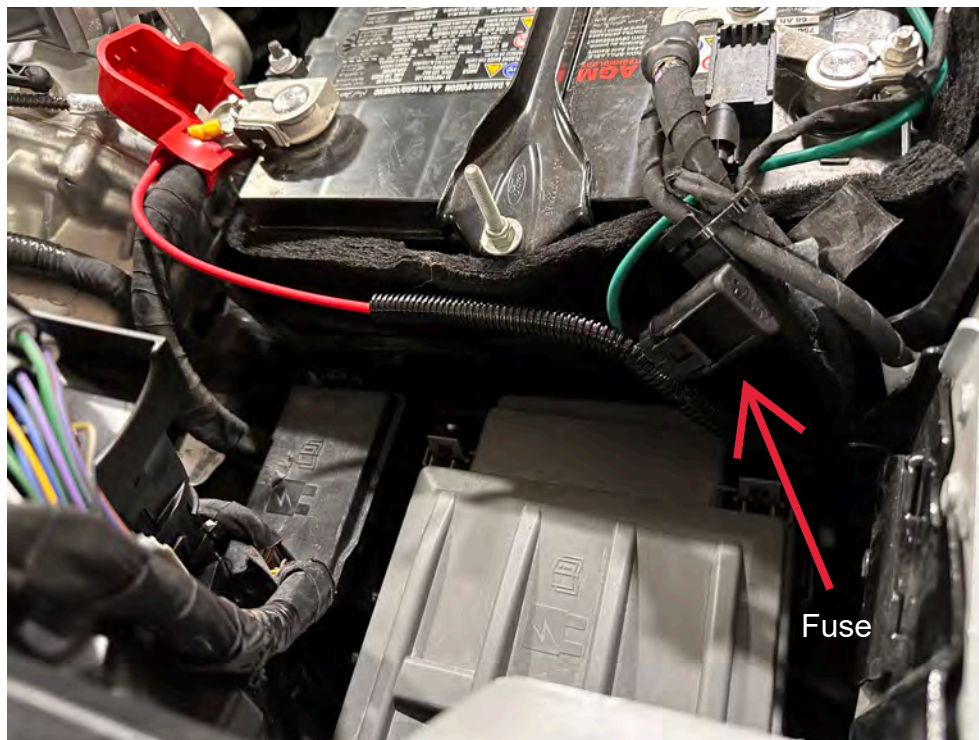



www.fassride.com

(866) 769.3747

STEP 1: ***INSTALLING ELECTRICAL HARNESS***

F. Route WH-1004-3 along the frame rail to the approximate mounting location near the fuel tank. **Completion of this step will be addressed in Step 3.**

The images below show the proper steps for disconnecting and connecting the quick-connect style fuel lines.

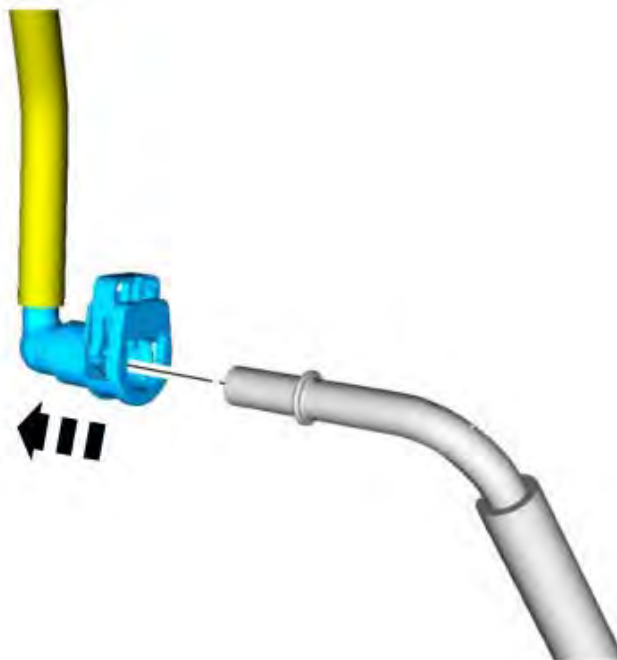
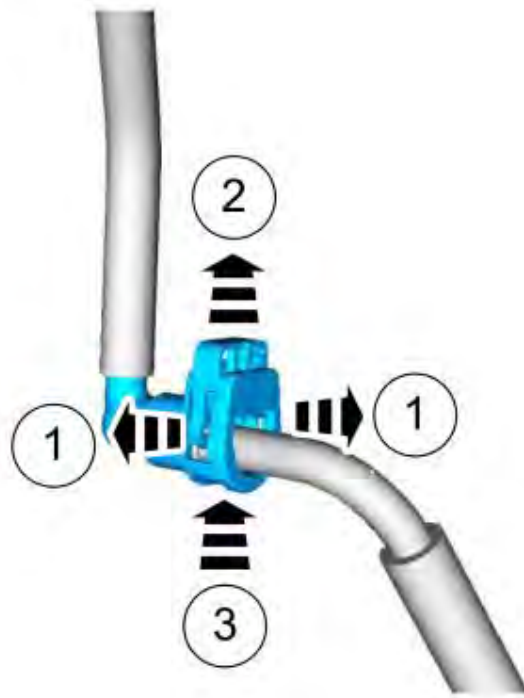

The images below show the proper steps for disconnecting and connecting the quick-connect style fuel lines.

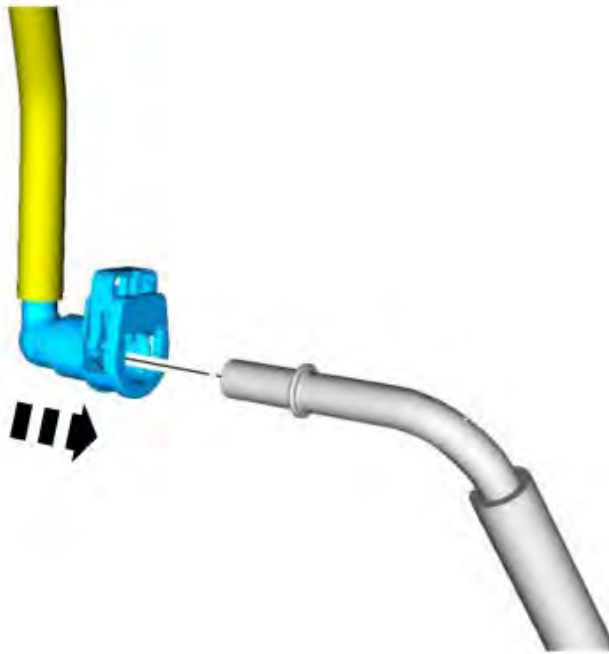

The images below show the proper steps for disconnecting and connecting the quick-connect style fuel lines.

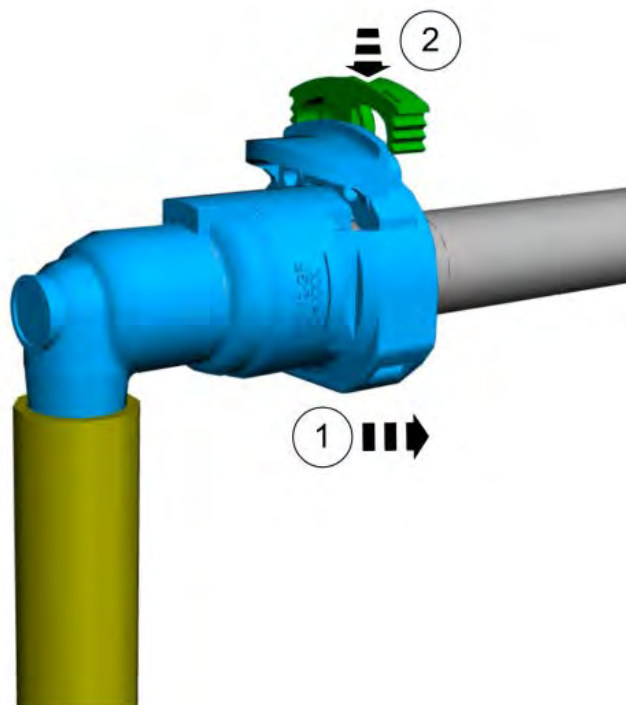
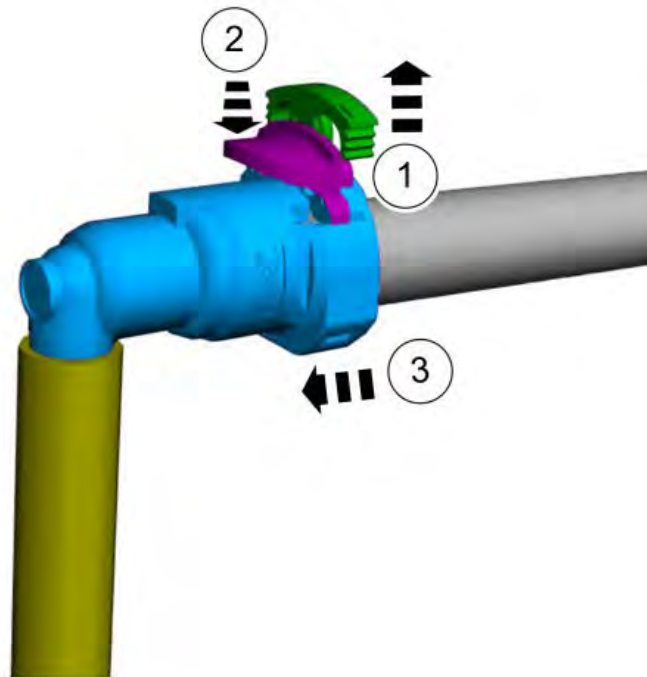

The images below show the proper steps for disconnecting and connecting the quick-connect style fuel lines.

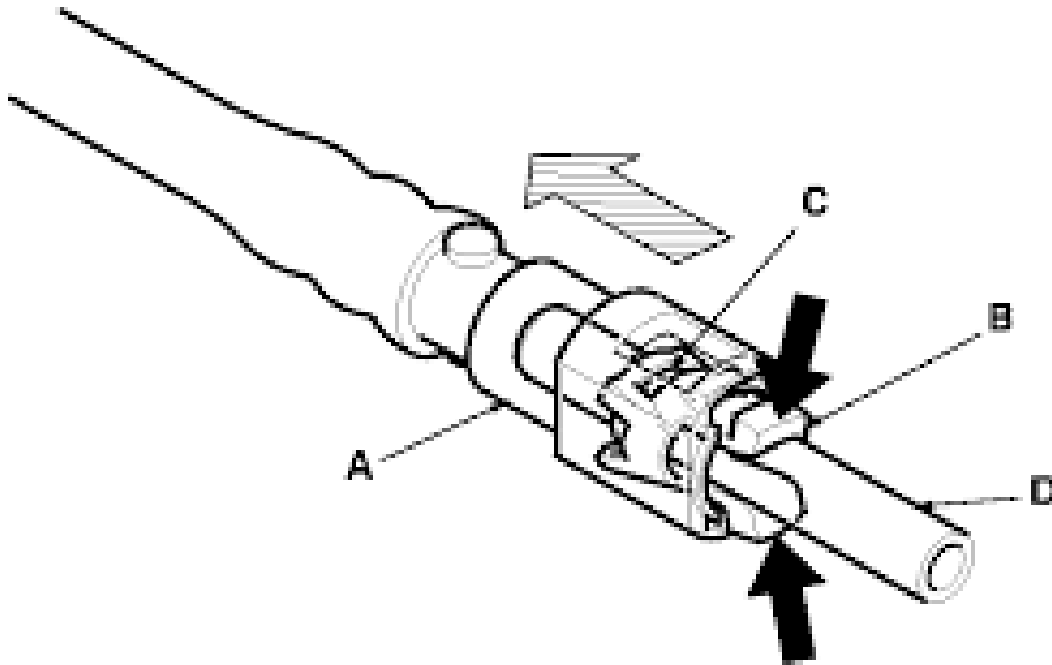

STEP 2:
PREPARE SUCTION & RETURN LINES

NOTE: ON TRUCKS WITHOUT THE OEM REAR MOUNTED FUEL FILTER WATER SEPARATOR SKIP TO STEP C.

A. Place a drain pan under the OEM rear mounted fuel filter housing assembly and drain the water separator.



STEP 2:
PREPARE SUCTION & RETURN LINES

- B.** Release the locking tabs and disconnect the two fuel lines from the OEM rear mounted filter housing.

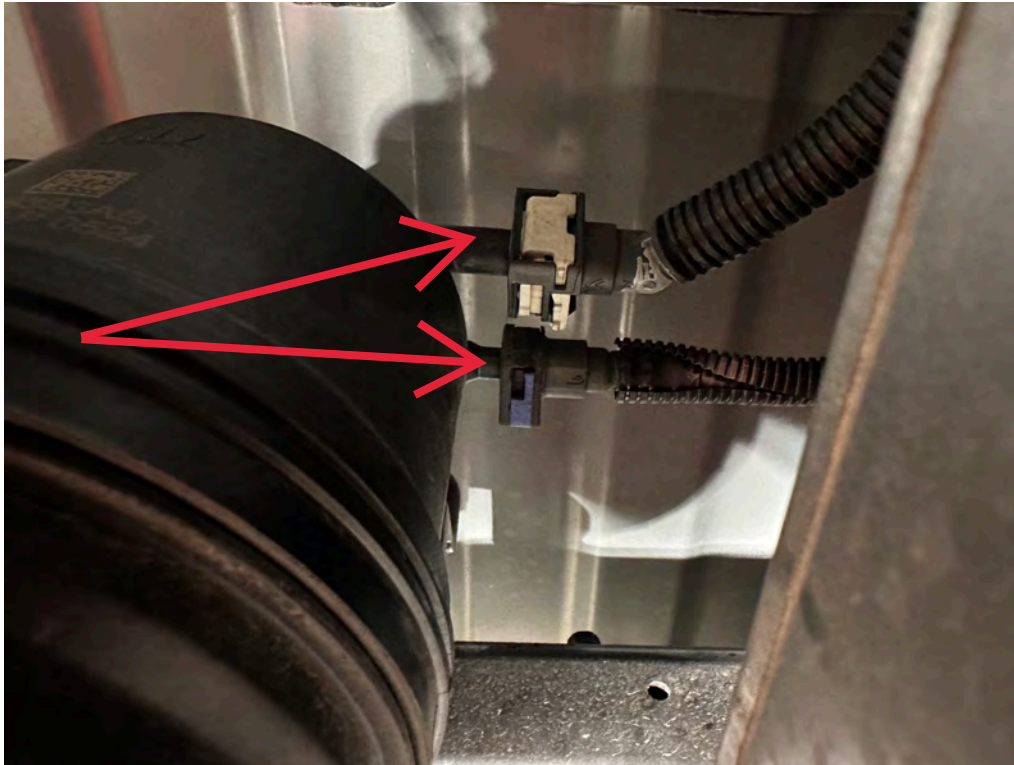

STEP 2: **PREPARE SUCTION & RETURN LINES**

- C.** Remove the filler neck and overflow tubes from the truck by loosening the clamps at both ends.

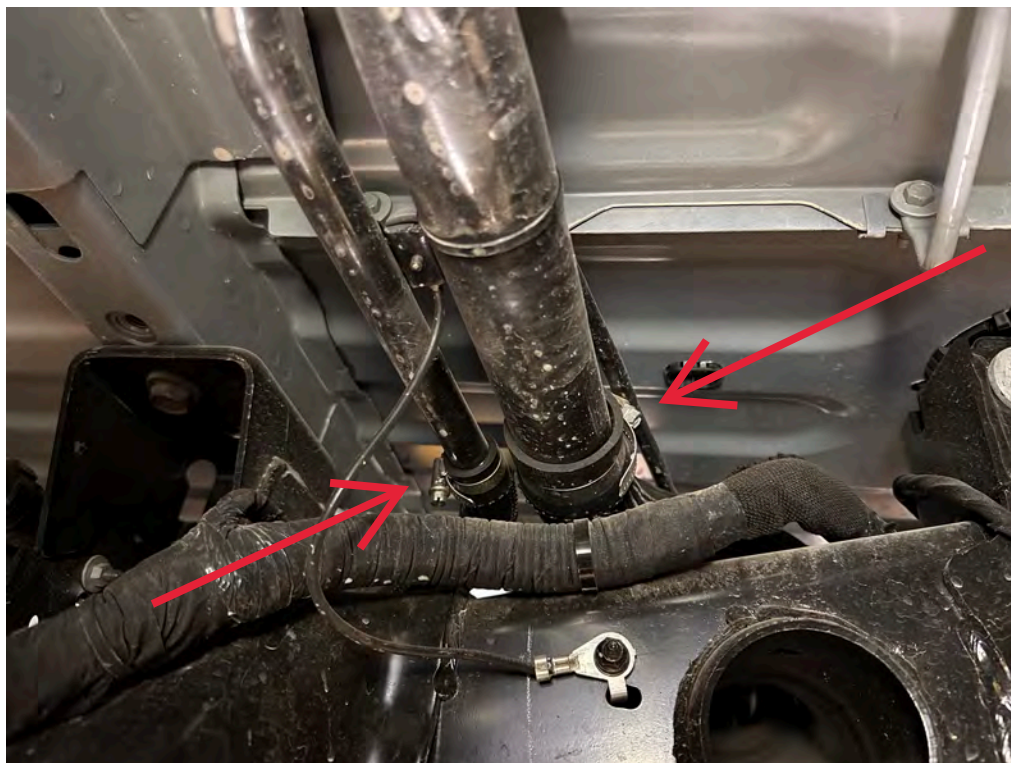

STEP 2: **PREPARE SUCTION & RETURN LINES**

- D.** Disconnect the factory electrical harness, suction line and return line from the fuel tank module.

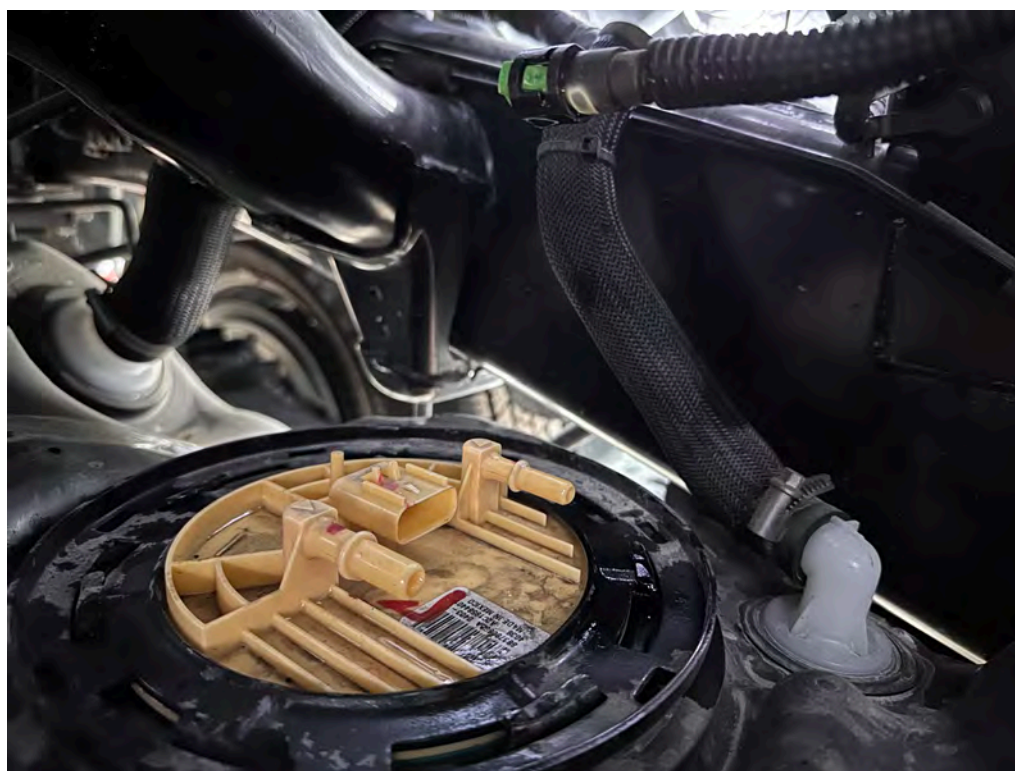
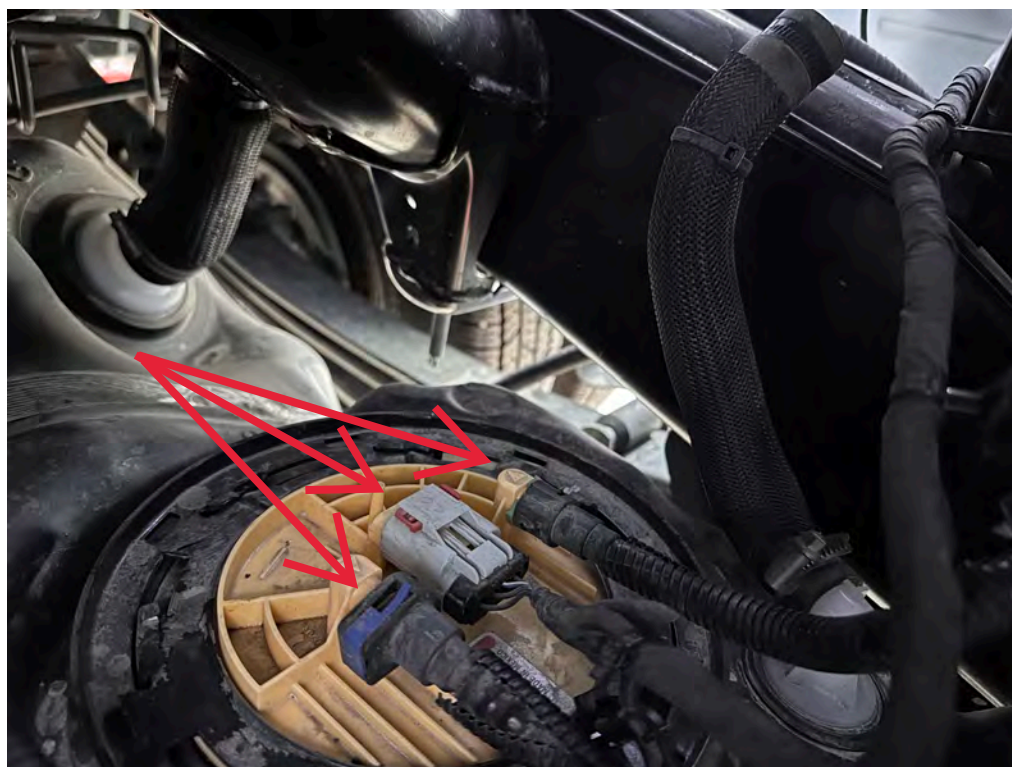

STEP 2:
PREPARE SUCTION & RETURN LINES

**NOTE: ON TRUCKS WITHOUT A OEM QUICK CONNECT
TANK VENT SKIP TO STEP F.**

E. Disconnect the factory tank vent



STEP 2: **PREPARE SUCTION & RETURN LINES**

F. With the fuel tank empty of fuel, unbolt the 2 tank straps and remove the tank from the vehicle.

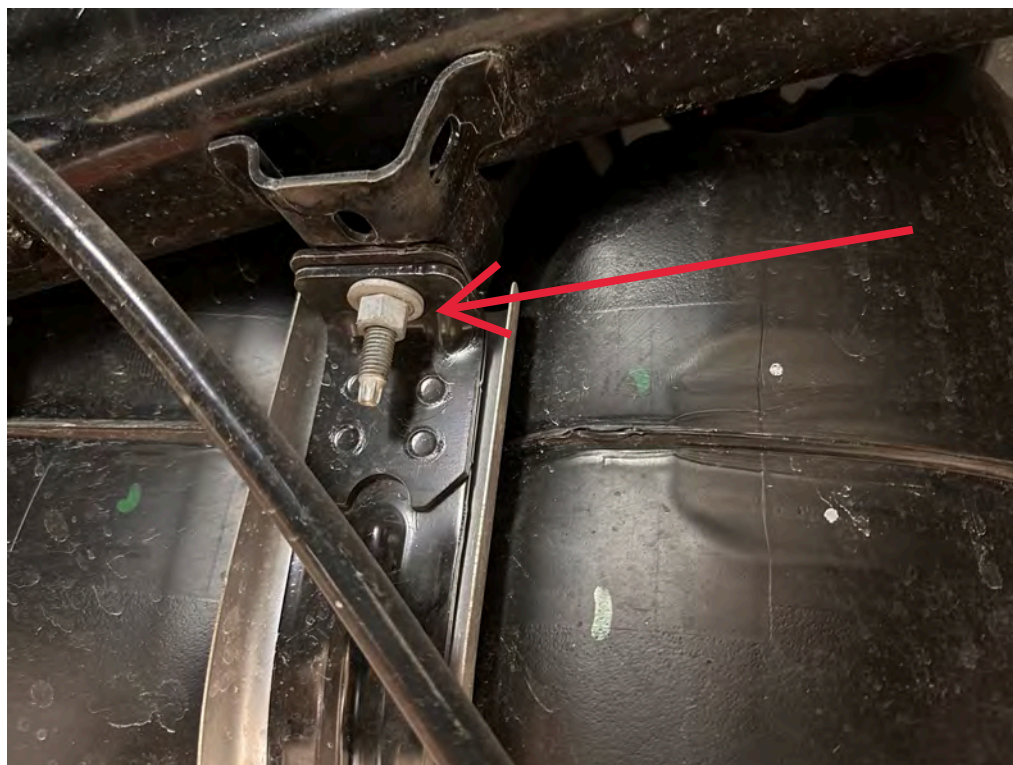
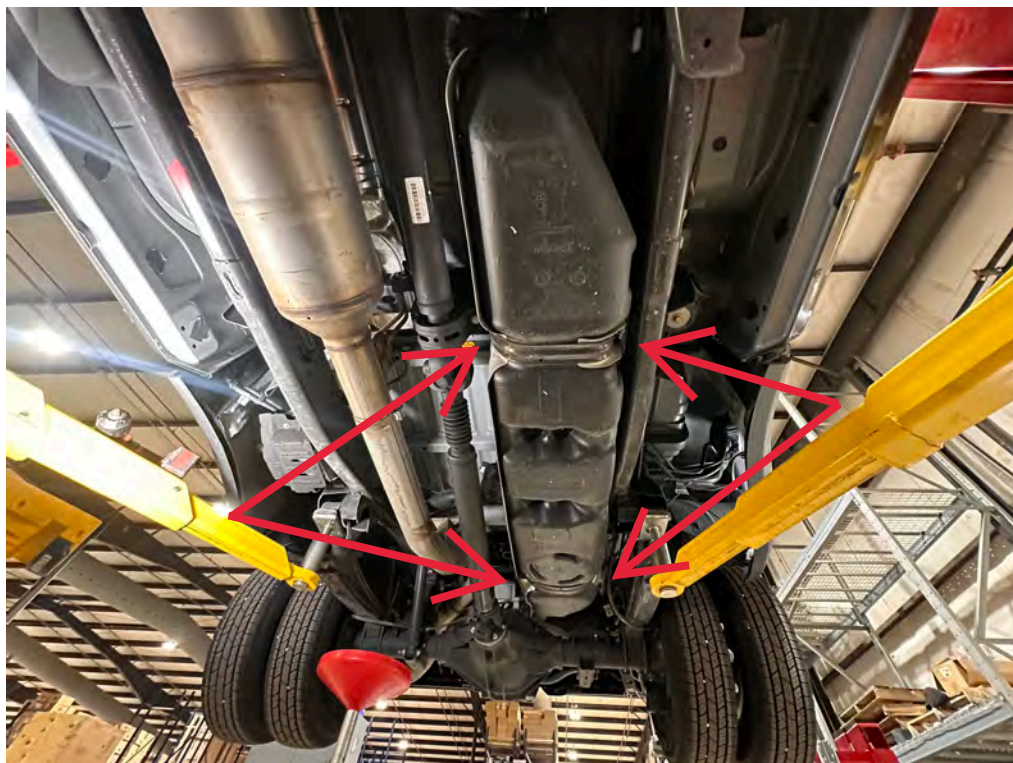

STEP 2:
PREPARE SUCTION & RETURN LINES

- G. Clean the fuel tank module area before removing the locking ring.



STEP 2: **PREPARE SUCTION & RETURN LINES**

H. Remove the lock ring on the top of the fuel tank. This is spring loaded, so, holding it down while removing the ring will prevent the sending unit from popping up and possibly causing damage. Note the location of the tab and arrow. Re-install the sending unit in the same location to prevent the fuel level arm from binding. Remove fuel tank module from fuel tank, be careful not to damage fuel level float.



STEP 2:
PREPARE SUCTION & RETURN LINES

**NOTE: SOME MODULES MAY REQUIRE YOU TO
CUT ZIP TIES SECURING THE WIRING**

- I. Remove the connector from the OEM fuel pump by releasing the locking tabs.

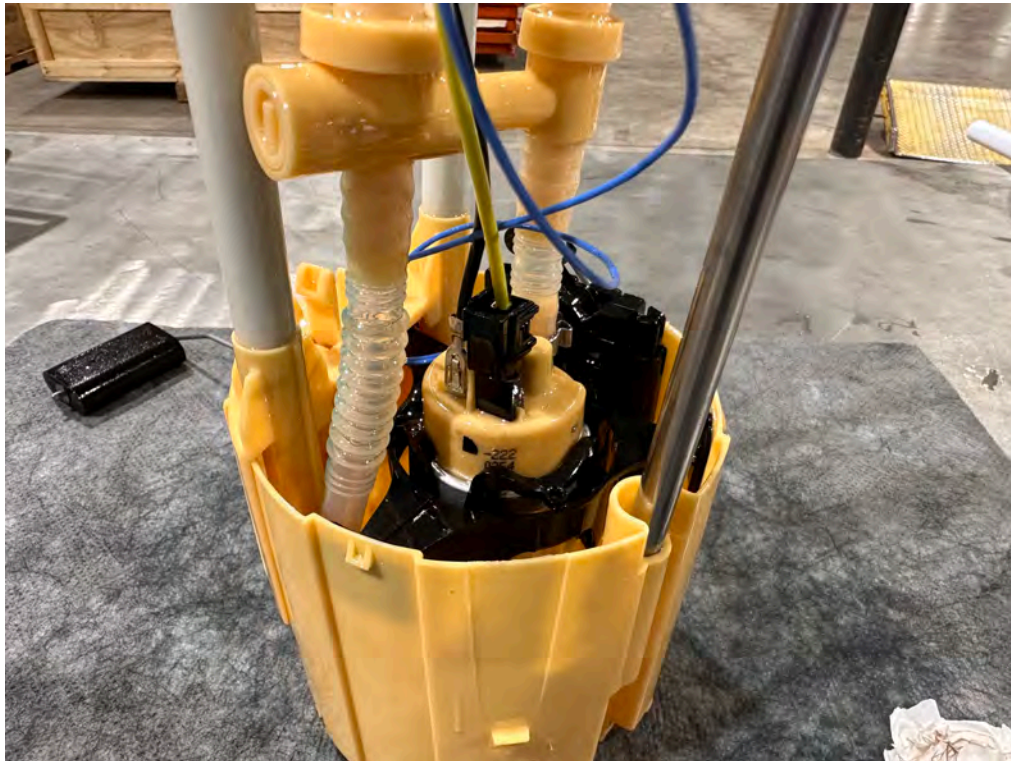

STEP 2: **PREPARE SUCTION & RETURN LINES**

J. Remove the OEM harness from the fuel tank module. Disconnect the fuel level sending unit from the fuel tank module to prevent damage. **THIS WILL BE INSTALLED AT A LATER TIME, DO NOT DISCARD!!!**

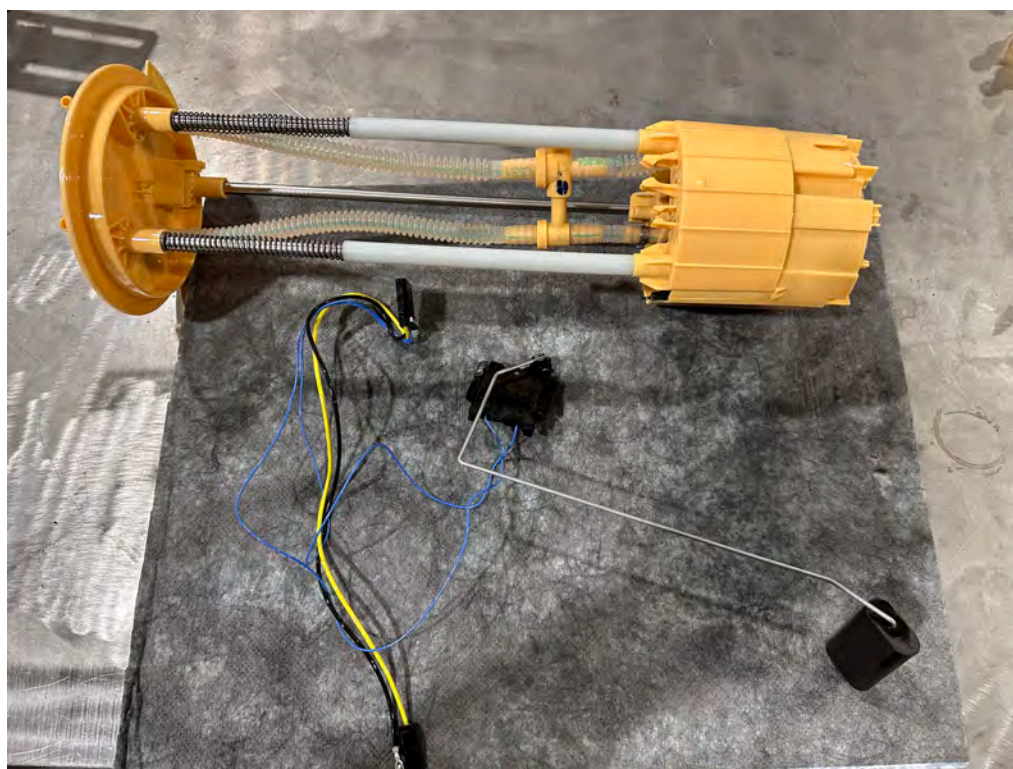

STEP 2: **PREPARE SUCTION & RETURN LINES**

K. Carefully remove convoluted tubing from the fuel tank module with a razor knife, be sure not to damage the hose barb beneath the tubing. Cut the retaining tabs that secure the OEM fuel pump, remove the fuel pump from the fuel tank module.



STEP 2: **PREPARE SUCTION & RETURN LINES**

- L. Remove the screen from the bottom of the fuel tank module and ensure all loose parts are removed.

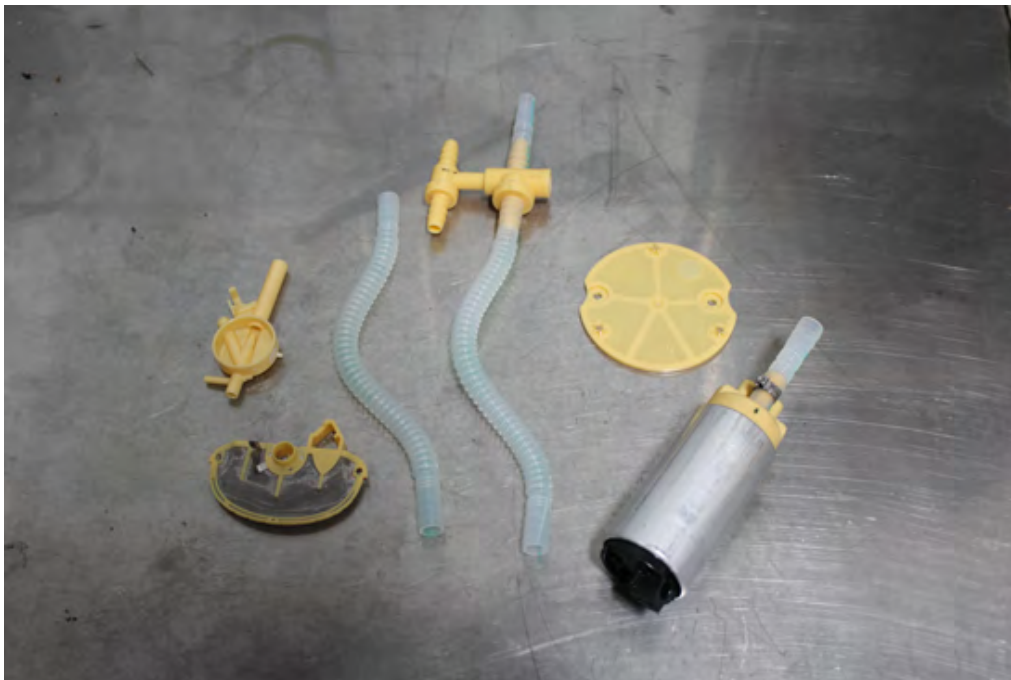
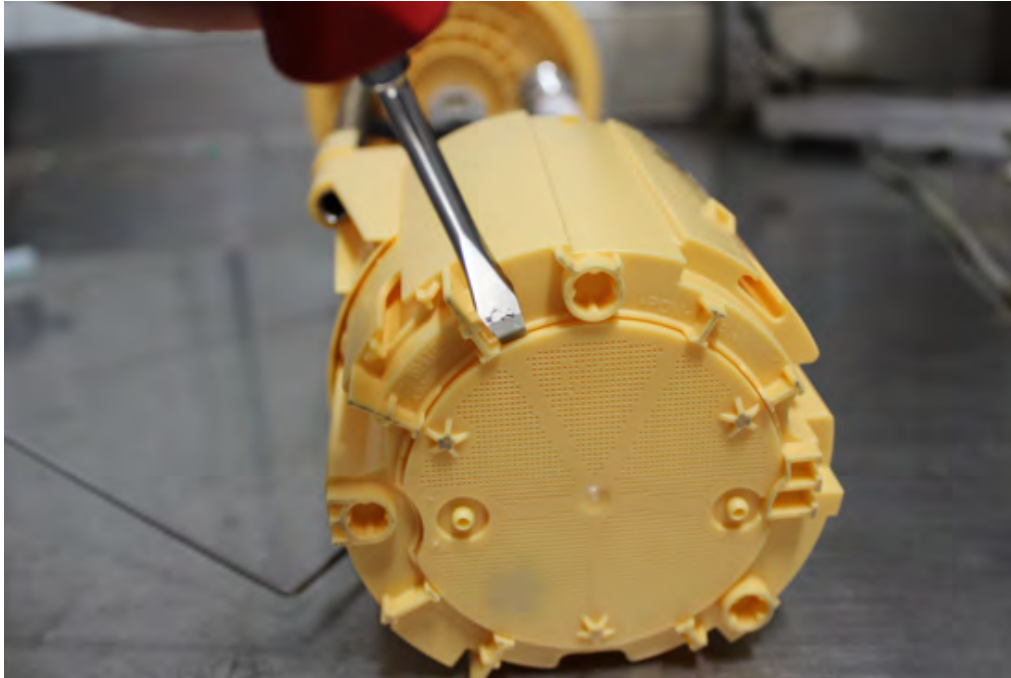

NOTE: These model year trucks came equipped with different style fuel tank modules. The installation process is the same, just note the different fitting installation locations below:

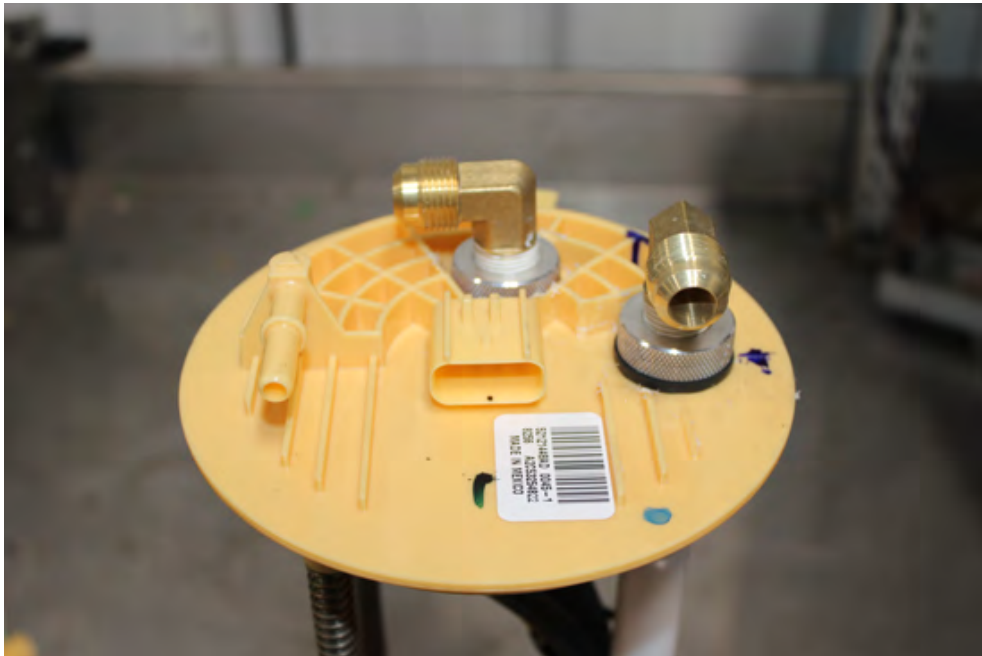

Most 2005-2018 Models



Most 2021 Models

STEP 2: **PREPARE SUCTION & RETURN LINES**

- M.** Carefully cut the OEM fuel FEED line off of the fuel tank module. Using a 7/8" hole saw, drill the center of the OEM feed port.

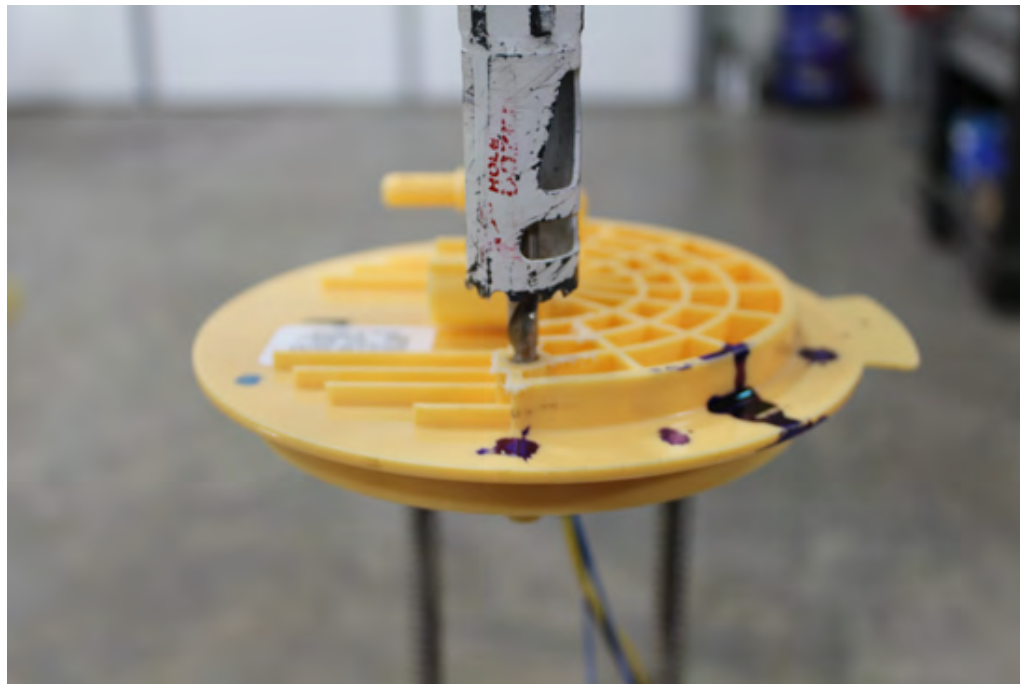

STEP 2: **PREPARE SUCTION & RETURN LINES**

N. Using a DA Sander, carefully remove the plastic webbing with enough clearance for BHF-1010. Mark the location for BHF-1008, drill using a 7/8" hole saw.

**NOTE: BE SURE TO DEBURR HOLE
YOU MUST CREATE AN ADEQUATE SEALING SURFACE FOR OR-119!!**



STEP 2: **PREPARE SUCTION & RETURN LINES**

- Install BHF-1010 (**WHERE THE OEM FUEL FEED LINE WAS REMOVED**) and BHF-1008 onto the fuel tank module with OR-119, apply Loc-Tite onto threads and install BHN-1005 onto BHF-1010 and BHF-1008. Tighten BHN-1005 to BHF-1010 and BHF-1008 accordingly.

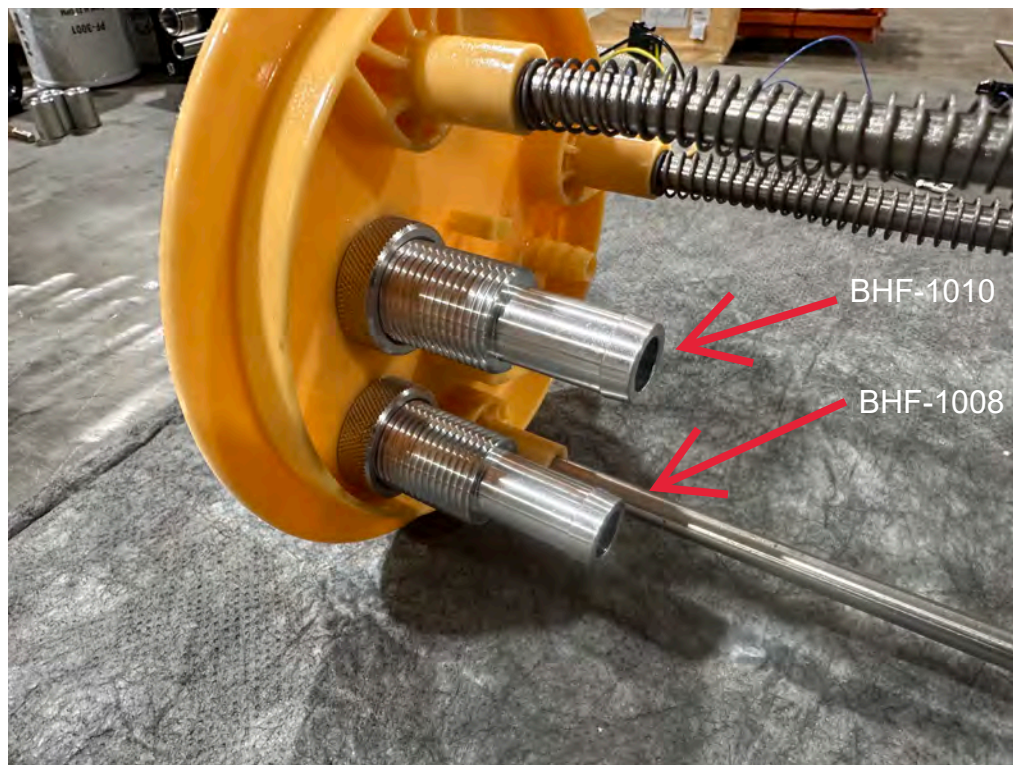

STEP 2:
PREPARE SUCTION & RETURN LINES

VERY IMPORTANT: Support fuel tank on both ends allowing the natural formation of the tank to take place. Failure to perform this step will hinder precision installation.



FUEL TANK SUPPORTS

STEP 2: **PREPARE SUCTION & RETURN LINES**

P. Using a tape measure, measure from the bottom of the fuel tank to the top of the o-ring sealing surface where the fuel tank module makes contact and take note of the measurement. **NOTE: ACTUAL MEASUREMENTS WILL VARY FROM IMAGES!**



STEP 2: **PREPARE SUCTION & RETURN LINES**

Q. Compress fuel tank module to the exact height measurement taken in previous step, measure and mark ST-1005P with 1/4-1/2" clearance from bottom of fuel tank module. Cut ST-1005P to length. Using grease, install ST-1005P onto BHF-1010 with hose clamp HC-1001.

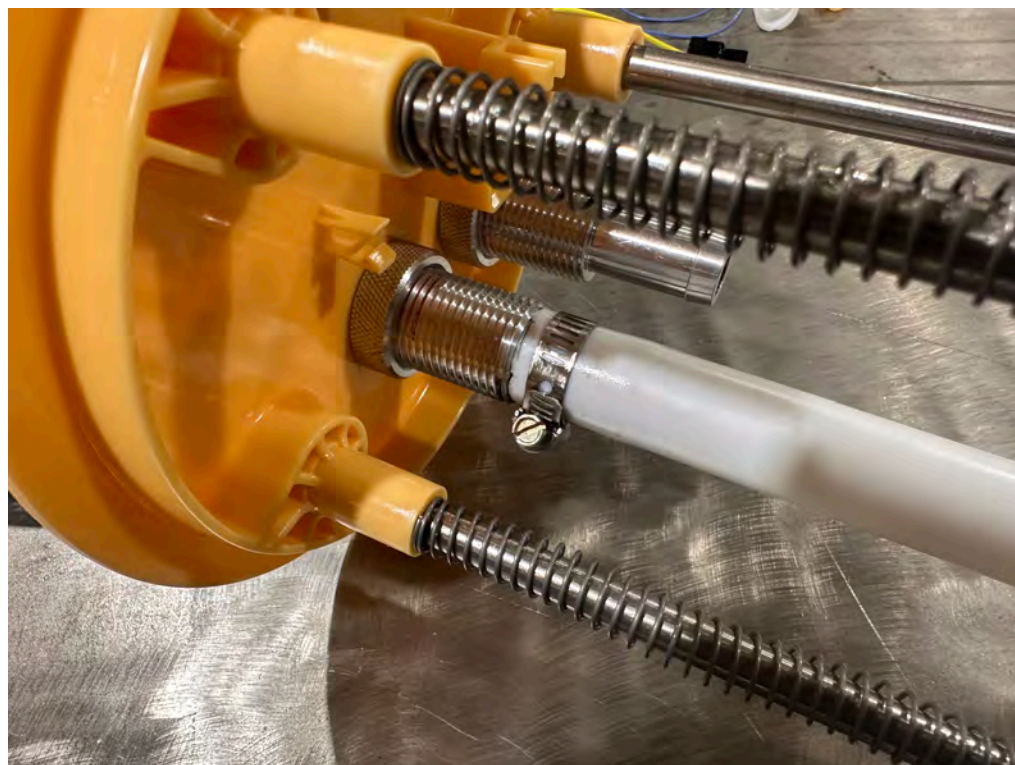

STEP 2: **PREPARE SUCTION & RETURN LINES**

R. Using grease, install FL-1007 onto BHF-1008 with 1" of clearance to the bottom of the fuel tank module using the same procedure as step "N".



STEP 2: **PREPARE SUCTION & RETURN LINES**

- S.** Using grease, install FL-1006 onto the OEM fuel return barb, FL-1006 may need to be trimmed to length. Neatly secure all of the fuel lines and electrical wires together using the provided cable ties.

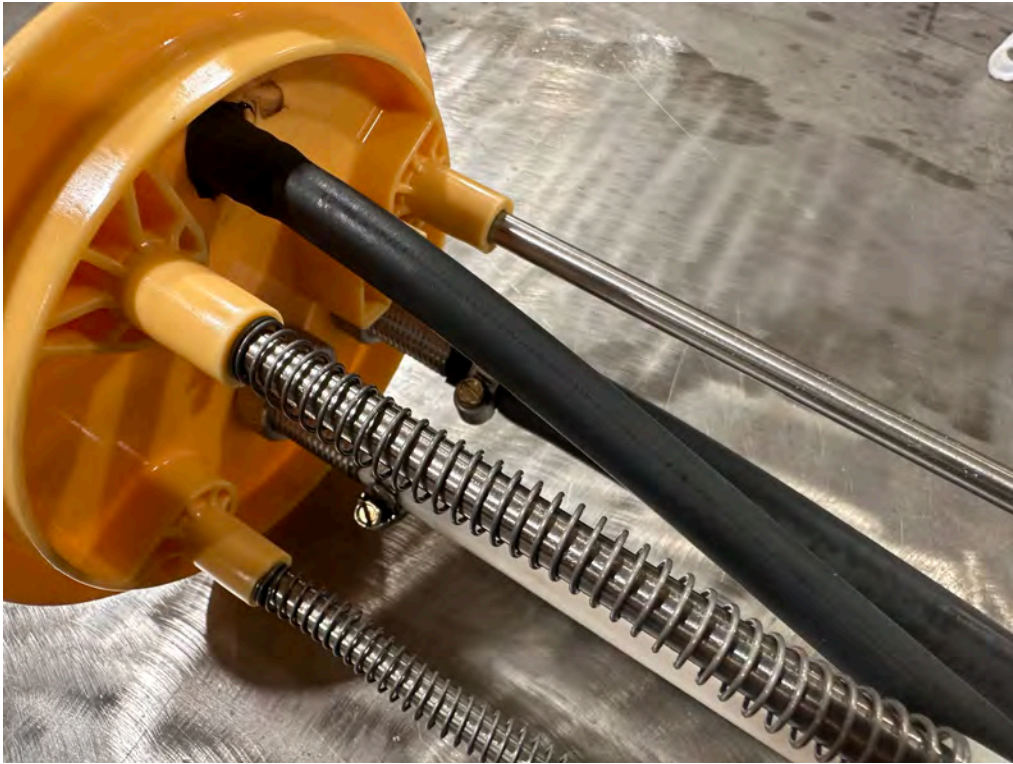

STEP 2: **PREPARE SUCTION & RETURN LINES**

T. Carefully reinstall install pick up module making sure the leveling arm is not obstructed by the suction tube. Reinstall factory lock ring.



STEP 2: **PREPARE SUCTION & RETURN LINES**

U. Using grease, press FL-1058-BK onto PL-2058-BK and pl-1002-BK onto PL-2003-BK. Install PL-2058-BK onto BHF-1010 and PL-2003-bk onto BHF-1008. Tighten accordingly.



STEP 2: **PREPARE SUCTION & RETURN LINES**

V. Reinstall the fuel tank by reversing the steps taken for removal. Loop FL-1002-BK and FL-1058-BK over the frame during tank installation. Connect WH-1004-3 (addressed in Step 1) to the fuel module and connect the factory wire harness to WH-1004-3



NOTE:

ATTENTION: While installing fittings into Titanium pump
DO NOT Apply side pressure to draw tube of pump

PROPER



IMPROPER

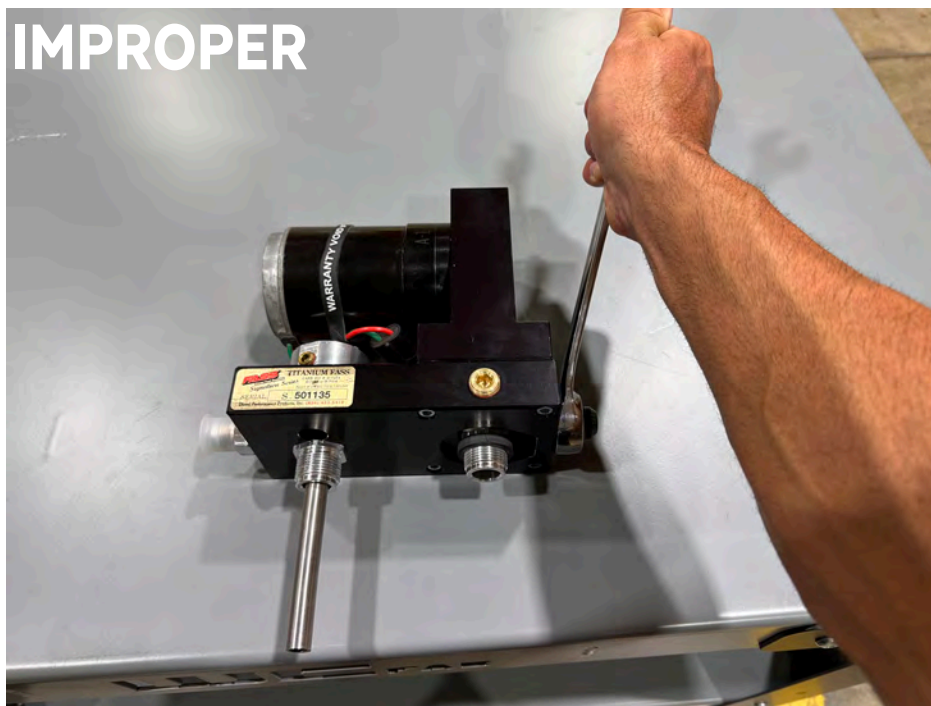

STEP 3: **MOUNT FUEL SYSTEM**

NOTE: Before installing fittings make sure to inspect for burs or flare imperfections. When cutting fuel line make sure to blow out line to keep debris from moving forward..

A. Install AN-8-ORB-10-BK into the "E" port and AN-10-ORB-10-BK into the "T" port of the FASS. Tighten accordingly.



STEP 3: **MOUNT FUEL SYSTEM**

B. For fitting purposes. Secure PBR-2001 to pump assembly lightly with (3) 1/4"-20x1 3/4 bolts and (3) WA-1001D. Assembly will be used in future steps for correct fitting of brackets. (Note: Bracket may-be flipped to accommodate your application.)

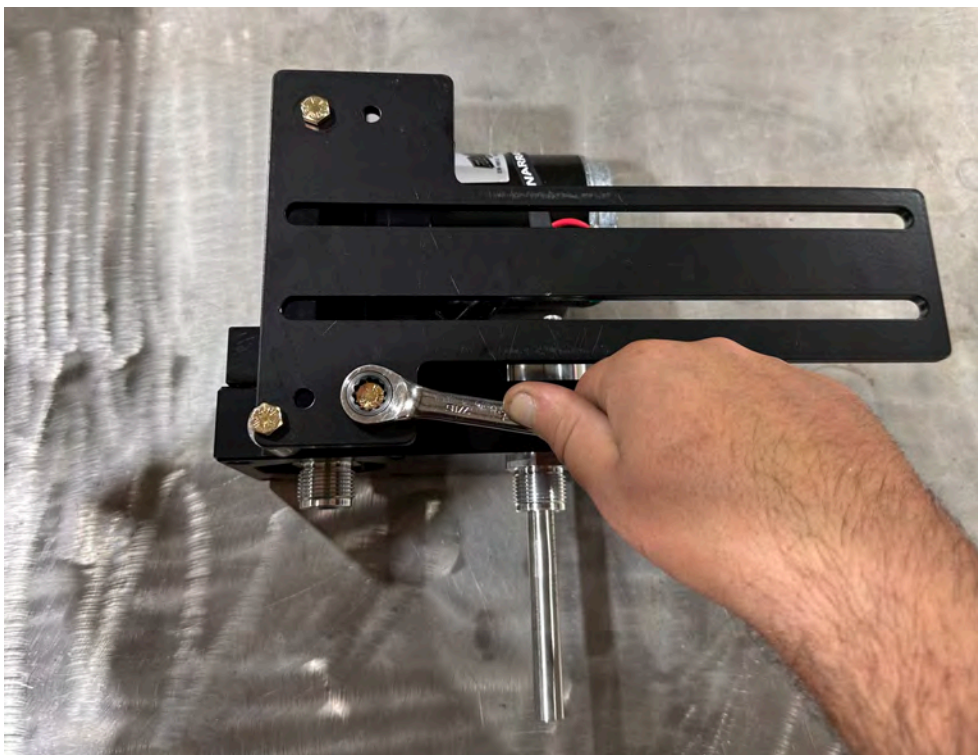
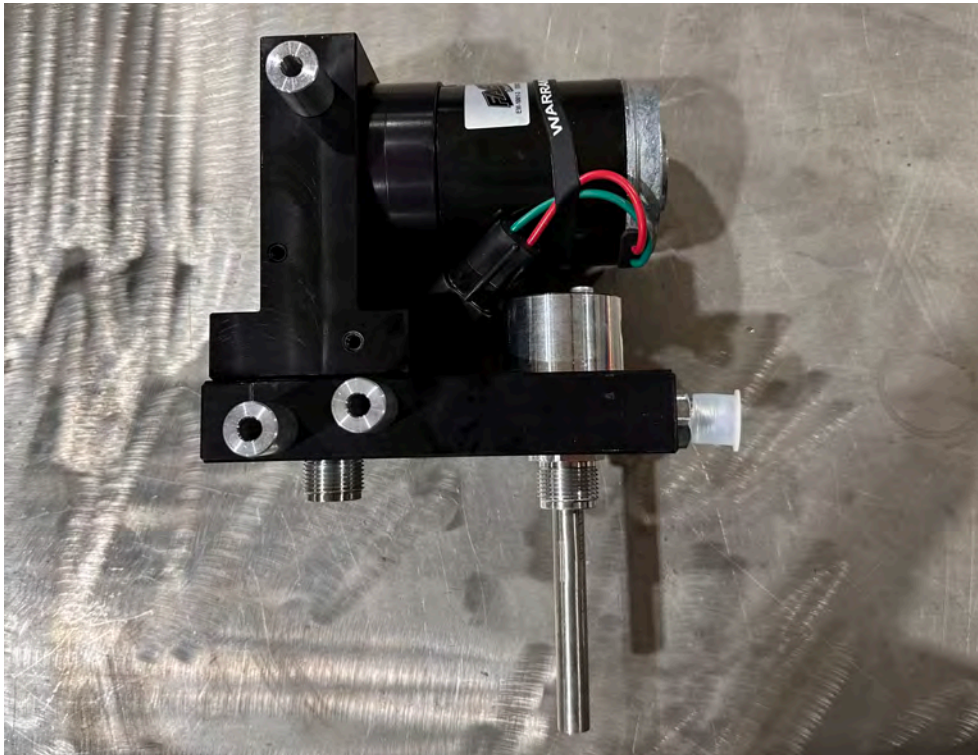

STEP 3:
MOUNT FUEL SYSTEM

****ATTENTION****

NOTE: SOME RAM MODELS MAY REQUIRE OUR DS-1001 ALUMINUM SPACER AND LONGER M12 1.75X60MM BOLT WHEN MOUNTING THE PFB-2002 AS SEEN BELOW!

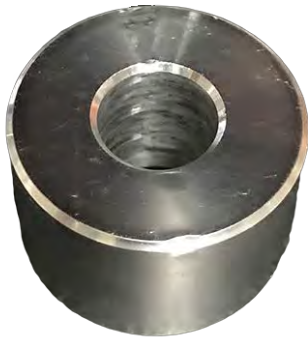

DS-1001



M12 1.75X60MM



USING THIS SPACER ALLOWS FOR PROPER CLEARANCE ON THE BED MOUNTS THAT HAVE THE ROLLED LIP LIKE THIS.

STEP 3:
MOUNT FUEL SYSTEM
1998.5-2013 Dodge Installation

C. Remove the driver side front bed, align RS-2001 with PFB-2002 and secure PFB-2002 with the bed bolt.



STEP 3:

MOUNT FUEL SYSTEM

2014-2024 LONG BED RAM INSTALLATION

C. Remove the driver side front bed, align RS-2001 with PFB-2002 and secure PFB-2002 with the bed bolt.



STEP 3:
MOUNT FUEL SYSTEM
2014-2024 SHORT BED RAM INSTALLATION

- C. Align RS-2001 with PFB-2002 and secure PFB-2002 with the provided bolt and washer.



STEP 3: **MOUNT FUEL SYSTEM**

- D. Position the PBR-2001 to the PFB-2002 pump assembly at the mounting location and check for fit. Once location is established mark location for mounting in next step.
NOTE: Some applications may require PBR-2001 to go on the back side of PFB-2002.
Once location is established mark location for mounting in next step.

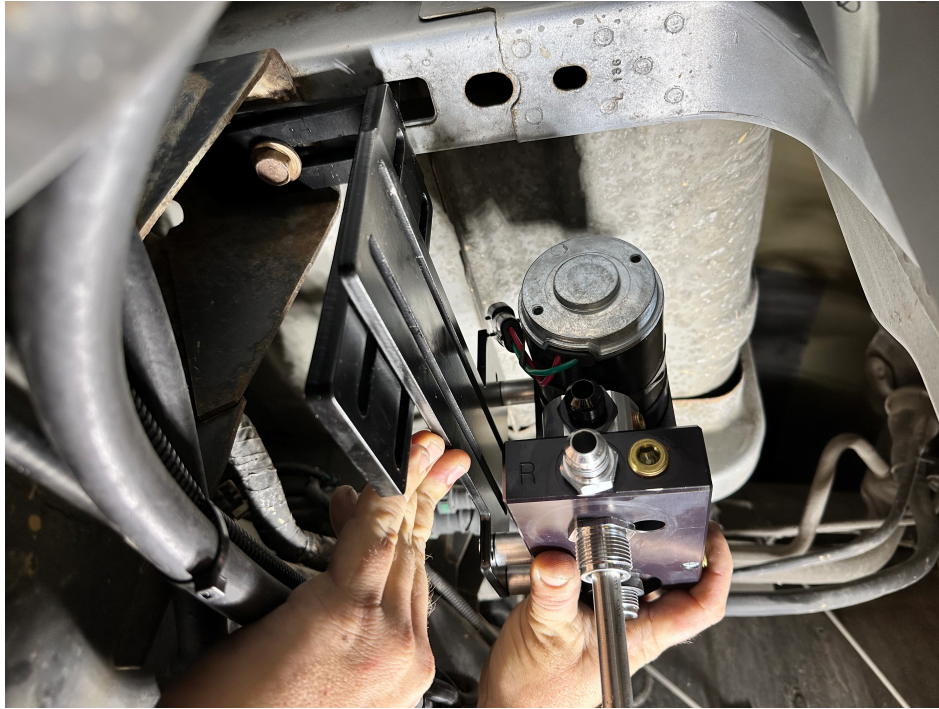

STEP 3: **MOUNT FUEL SYSTEM**

E. Assemble the FASS pump bracket PBR-2001 using the RS-2002 spacer (NOTE: Some applications may require PBR-2001 to go on the back side of PFB-2002) between PFB-2002 and PBR-2001 bracket with 4-3/8 bolts, nuts, and washers. Note: Torque bolts not flange nut.



STEP 3: **MOUNT FUEL SYSTEM**

- F. Once secure use (3) 1-3/4 bolts and (3) WA-1001D spacers to mount the pump to the bracket.



STEP 3: **MOUNT FUEL SYSTEM**

NOTE: If fuel pressure gauge is pulsating after FASS installation, use snubber valve (Cat Part # 7S-3795)

G. Apply grease to the gasket located on the filters. Attach to the system and hand tighten.



**Extreme Water Separator -
Install XWS-3002 on side of
pump with draw tube in the
middle of the filter nipple.**



**Particulate Filter -Install PF-3001 on
filter nipple without the draw tube.
Make sure to insert O-Ring provided
on nipple.**



Note: O-Ring must be put back on the suction side of pump. Failure to do so can result in priming issues, cavitation or pressure losses.

NOTE:

ATTENTION: IT MAY BE NECESSARY TO ADJUST THE PARKING BRAKE CABLE BRACKET ON SOME MODELS FOR PROPER CLEARANCE!!



STEP 4: **INSTALL FUEL LINES**

- A.** Rout FL-1058-BK to the T port on the FASS and cut FL-1058-BK to length. Using grease, press PL-2058-BK into FL-1058-BK and connect to AN-10-ORB-10-BK. Tighten accordingly.

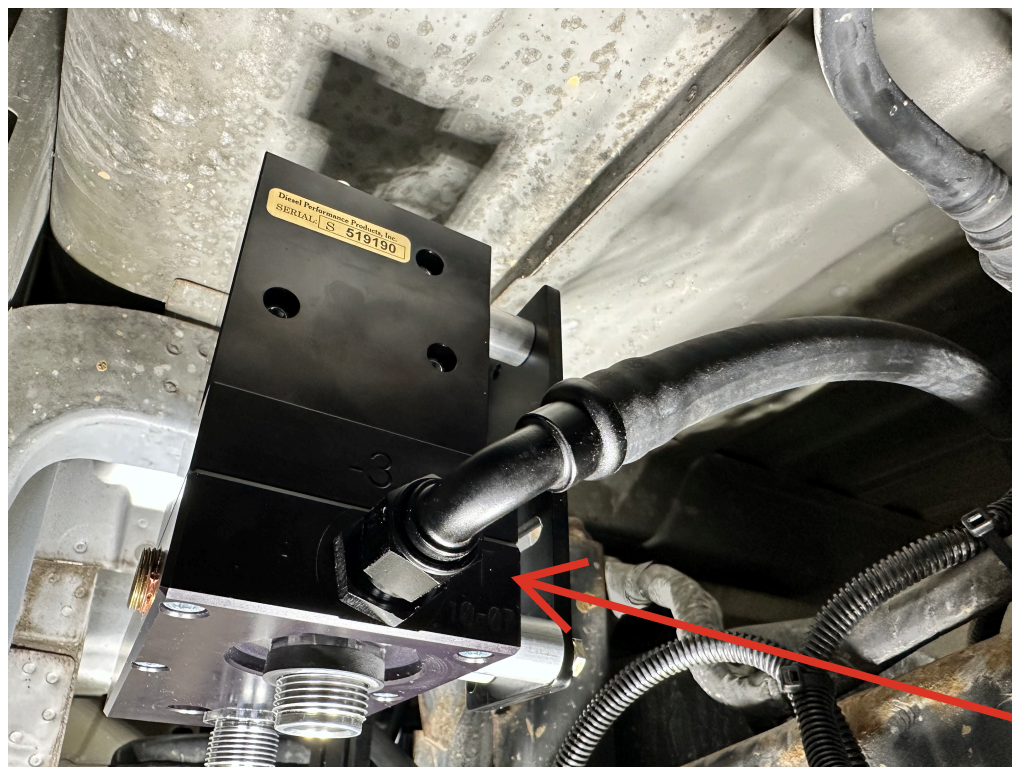

STEP 4: **INSTALL FUEL LINES**

B. Rout FL-1002-BK to the R port on the FASS and cut FL-1002-BK to length. Using grease, press PL-1005-BK into FL-1002-BK and connect to the R port on the FASS. Tighten accordingly.

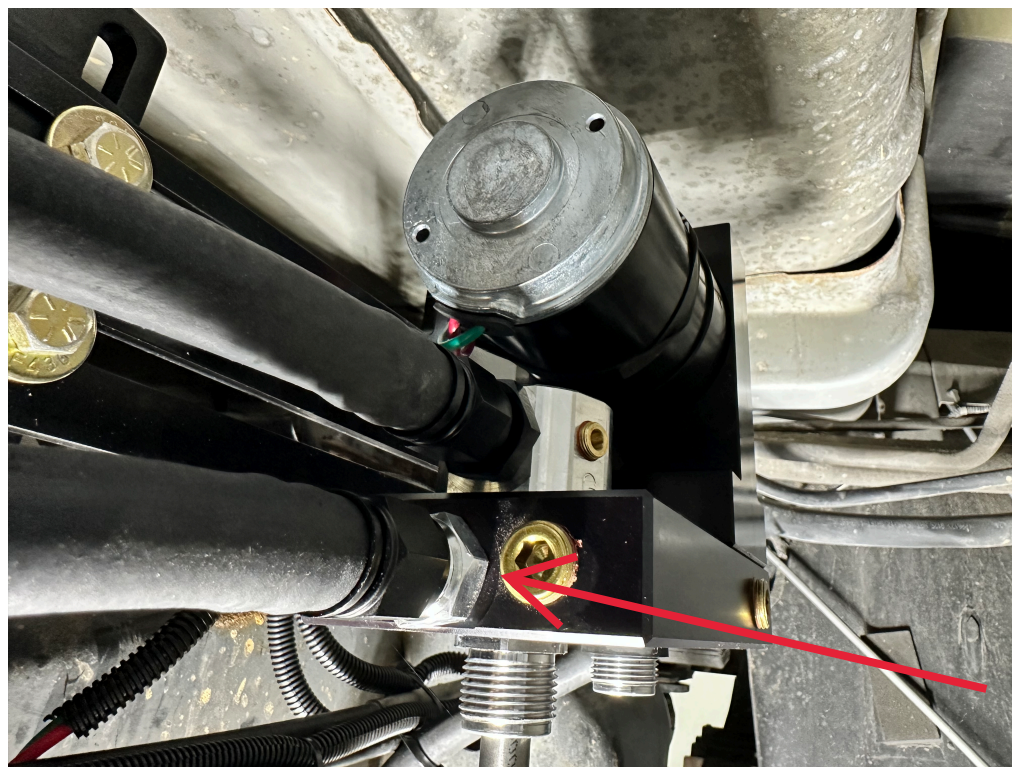

STEP 4: **INSTALL FUEL LINE**

1998.5 - 2002 VP44 (Injection Pump)

C. Disconnect factory fuel line from inlet side of the factory injection pump, Install the DIPF-1003 fuel fitting into this inlet port. (Note: This is where the suction fuel line from the fuel filter enters the injection pump.)



STEP 4:
INSTALL FUEL LINE

2003-2007 CP3 (Injection Pump)

- C. Remove the OEM fuel supply banjo bolt and discard.

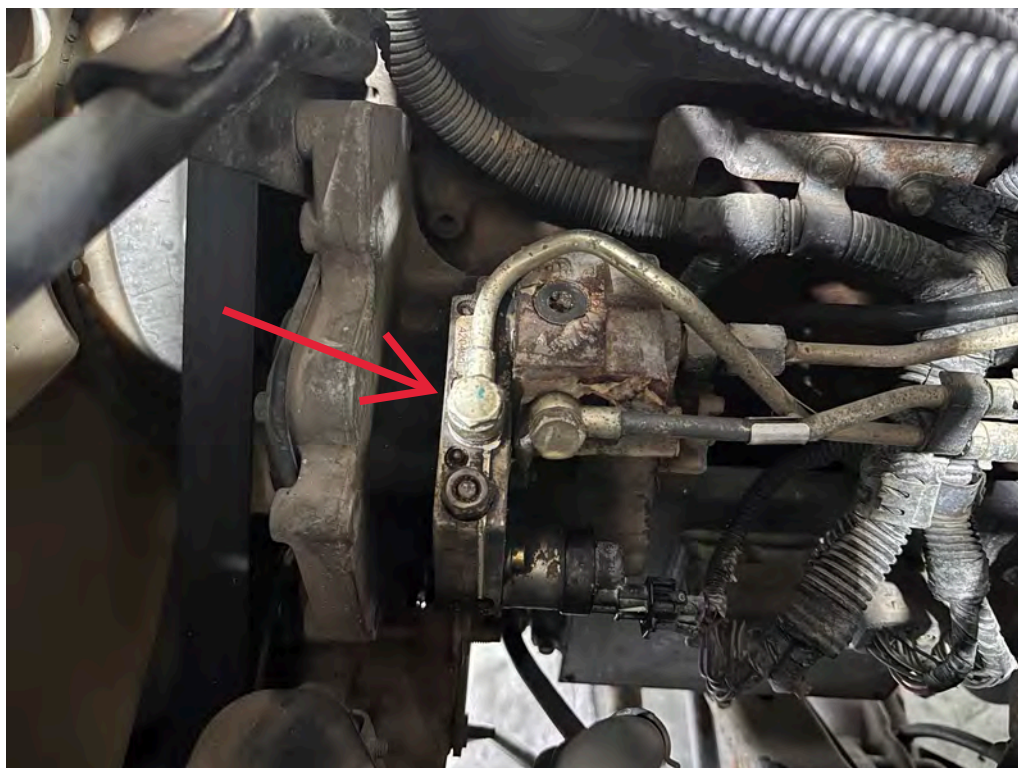

STEP 4:
INSTALL FUEL LINE

2007.5-2024 CP3 (Injection Pump)

- C. Remove the OEM fuel supply line from the CP3 then remove fitting.

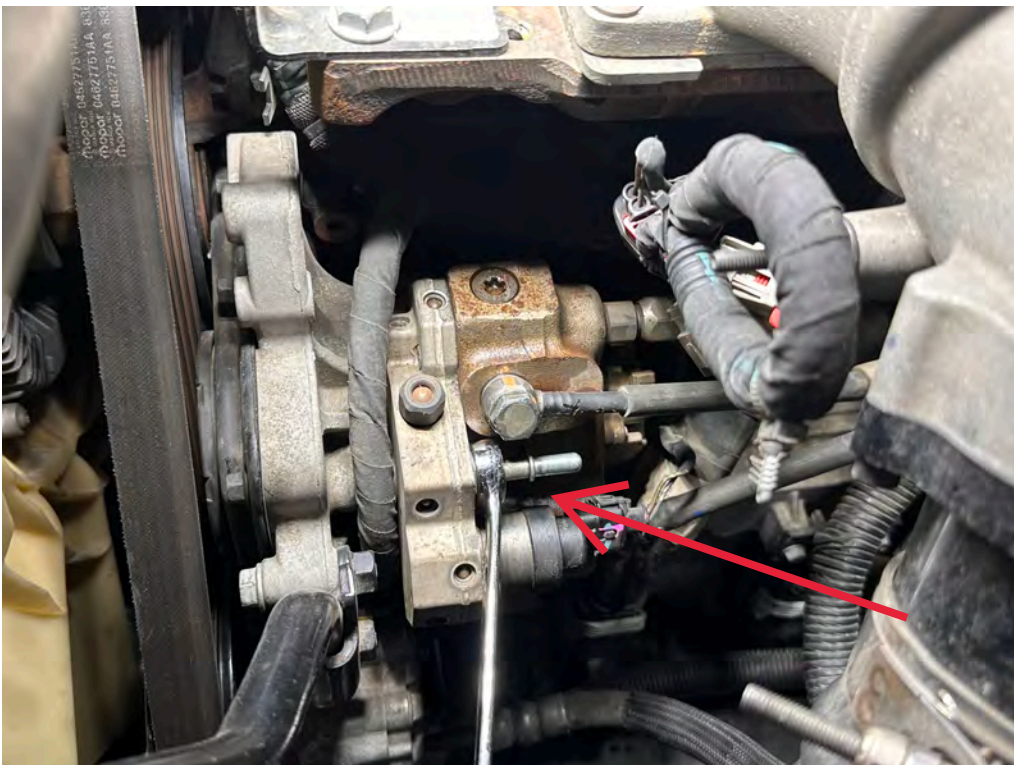
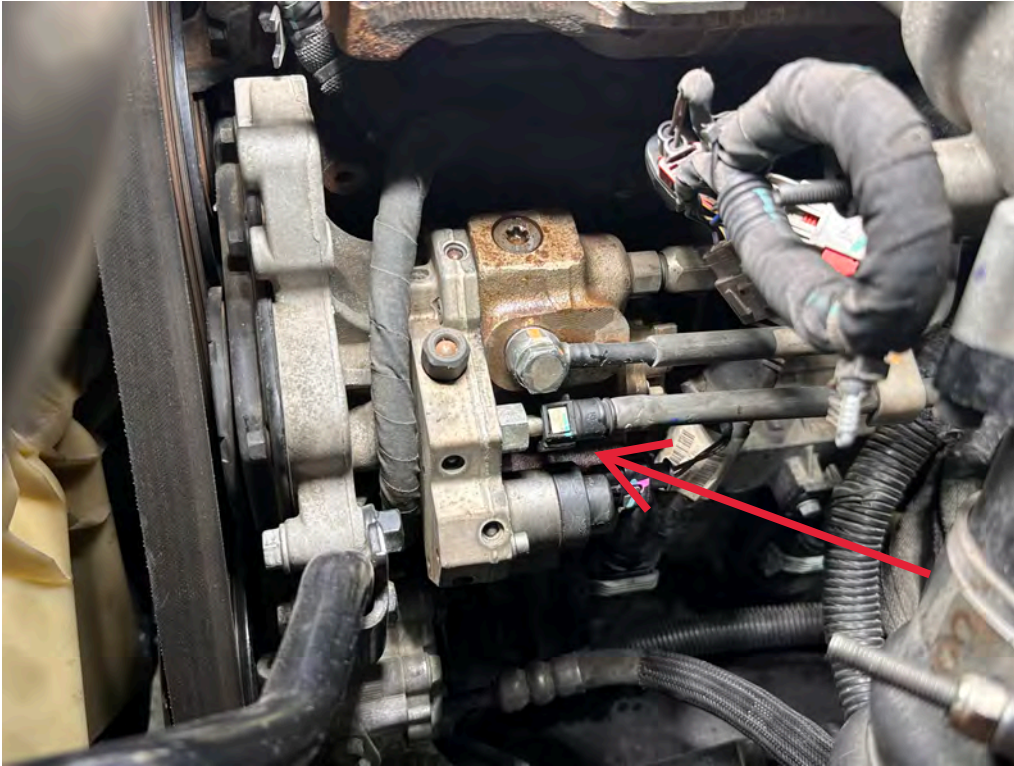

STEP 4:
INSTALL FUEL LINE
2003-2007 CP3 (Injection Pump)

- D. Install DIPF-1003 in place of the OEM fuel supply banjo bolt and tighten accordingly.



STEP 4:
INSTALL FUEL LINE
2007.5-2024 CP3 (Injection Pump)

- D. Install DIPF-1003 in place of the OEM fitting and tighten accordingly.

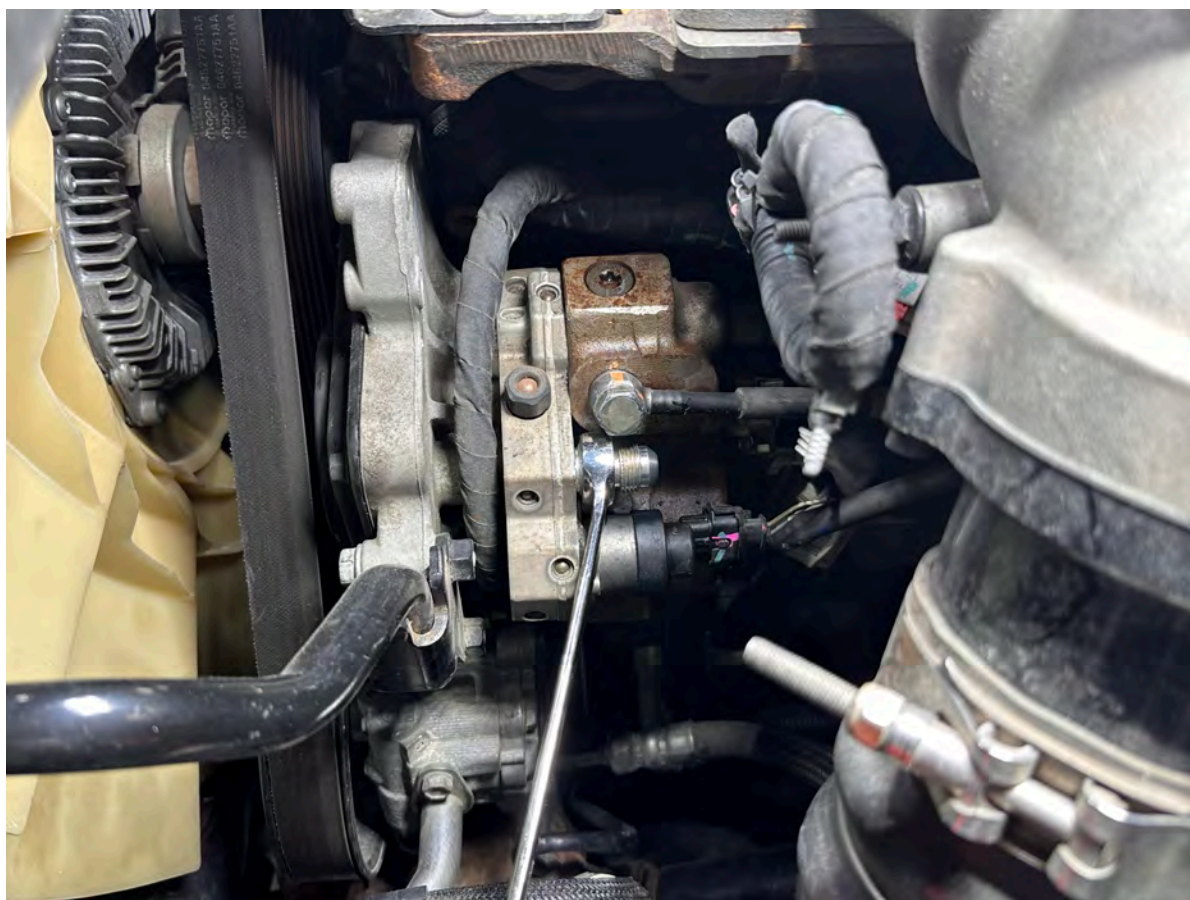

STEP 4:
INSTALL FUEL LINE

1998.5 - 2002 VP44 (Injection Pump)

E. Using grease, press PL-2003-BK into FL-1002-BK and install onto DIPF-1003. Route FL-1002-BK to the E port of the FASS and trim accordingly.



STEP 4:
INSTALL FUEL LINE

2003-2007 CP3 (Injection Pump)

E. Using grease, press PL-2003-BK into FL-1002-BK and install onto DIPF-1003. Route FL-1002-BK to the E port of the FASS and trim accordingly.



STEP 4:
INSTALL FUEL LINE

2007.5-2024 CP3 (Injection Pump)

E. Using grease, press PL-1005-BK into FL-1002-BK and tighten onto DIPF-1003. Route FL-1002-BK to the E port of the FASS and trim accordingly.

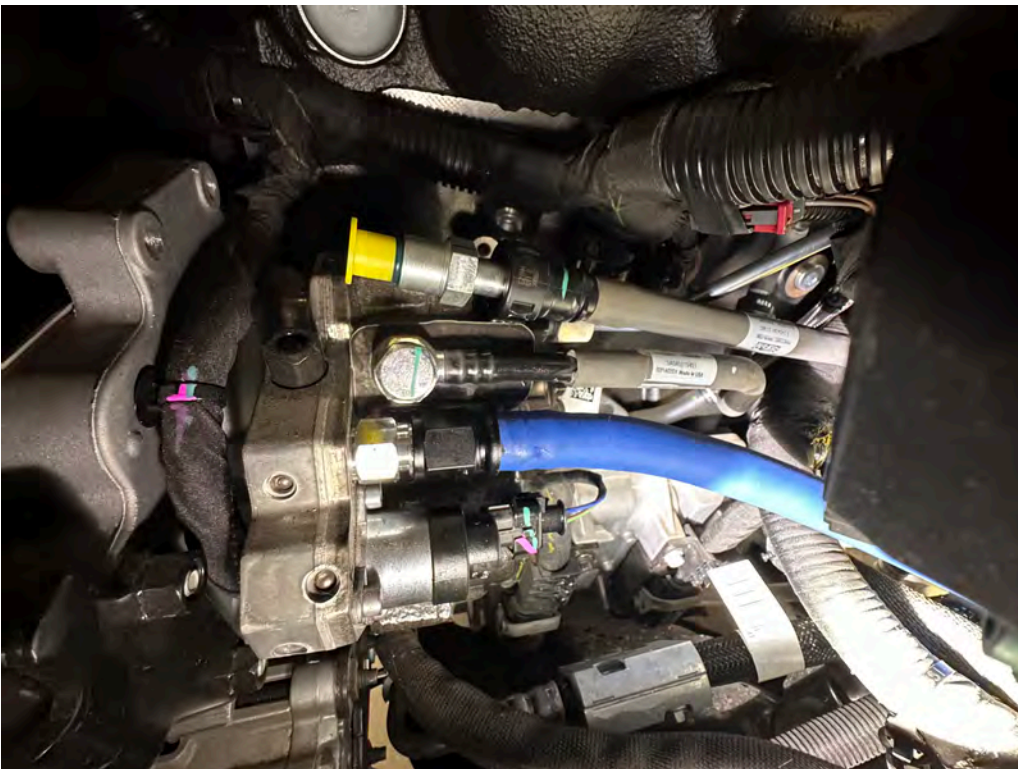

STEP 4: **INSTALL FUEL LINES**

F. Using grease, press PL-1005-BK into FL-1002-BK and tighten onto the E port of the FASS and tighten accordingly.

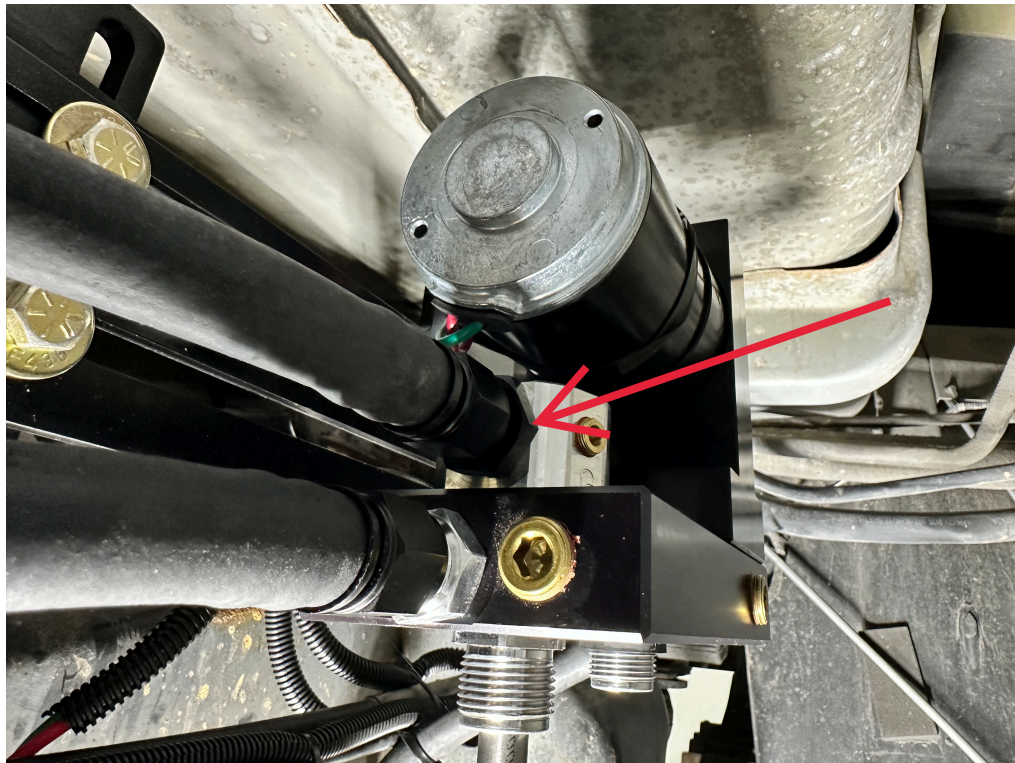

STEP 4: **INSTALL FUEL LINE**

G. Connect electrical connector on the FASS to the WH-1004-3, turn the key to the "RUN" position and spray WD-40 into the suction side of the FASS. This will allow easier priming of the FASS System.



NOTE: SECURE ALL FUEL LINES AND ELECTRICAL COMPONENTS AWAY FROM ANY MOVING PARTS USING THE SUPPLIED CABLE TIES!!!



STEP 5: **REVIEW INSTALLATION**

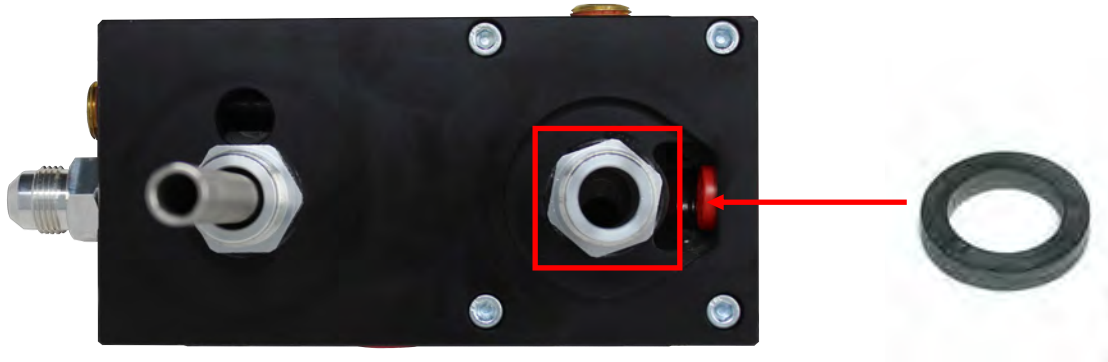

Note: O-Ring must be put back on suction side of pump. Failure to do so can result in priming issues, cavitation, or pressure losses.

1. **Blow out any open lines/cover any open ports**
2. **Bolts and fasteners properly tightened?**
3. **Electrical harness and fuel lines secured and properly tightened? Reconnect the battery.**
4. **Has the system been primed?**
 - a. **Turn key to the ignition position, turning on the FASS pump for 15 sec..**
 - b. **Crank engine and allow to run for at least 1 minute.**
5. **Check for leaks.**
6. **Start the engine**
7. **Recheck all fluid and filter connections for leaks**
8. **This pump comes with a 1 Year Manufacturer's Warranty based on the date it has been manufactured. To receive your extended Lifetime Warranty, you have 30 days from date of purchase to send the completed warranty information**



www.fassride.com

(866) 769.3747

LIMITATION OF LIFETIME WARRANTY

Disclaimer: To help insure you receive the proper system and customer support at the local level, FASS has a VIP and Authorized Dealer network representing FASS products. This is one reason you must purchase through a dealer to comply with our warranty policies. If you do not, there is no warranty! We recommend you go to www.FASSride.com, click "Find a Dealer", put in their ZIP code, select the type of dealer, and see if the company you purchased from is listed. If they are not, put their phone number in the field below the ZIP code field to see if they are listed. Below these two fields is a list of "Terminated/Unauthorized" dealers. You may want to review this list. If the company is not listed or is on the "Terminated/Unauthorized" list, we suggest you return the product immediately to that dealer and call FASS. We'll recommend you to the nearest dealer.

Diesel Performance Products, Inc. (hereafter "SELLER") gives Limited Warranty as to description, quality, merchantability, fitness for any product's purpose, productiveness, or any other matter of SELLER'S product sold herewith. The SELLER shall be in no way responsible for the product's open use and service and the BUYER hereby waives all rights other than those expressly written herein. This Warranty shall not be extended or varied except by a written instrument signed by SELLER and BUYER.

When MANUFACTURER receives the "ORIGINAL" PRODUCT REGISTRATION form with a copy of the "BILL OF SALE/SALES RECEIPT" within 30 days of the sale, then the following applies! The Warranty will then and only then be validated to that of which typically accompanies your unit for your specific application from the date of sale or for recommended service life and limited solely to the original purchaser and/or vehicle and parts contained within the product's kit. This warranty does not cover normal wear on consumable items such as but not limited to filters, fuel line, wire harness & etc. The warranty does not cover seized gears due to lack of filtration. Warranty is voided if used with other than diesel fuel. Returned items will arrive prepaid to the place of purchase. Diesel Performance Products, Inc. will repair, without cost, any product found to be defective during the warranty period; parts only, or at its option, will replace such products in exchange for the product. Repair or replacements are warranted for the remainder of the original warranty period. All Warranty claims are subject to approval by Diesel Performance Products, Inc.

A Return Material Authorization (RMA) number must be obtained before any product is to be returned to Diesel Performance Products, Inc. for warranty consideration, repair or product return. Requests for product returns must be offset by an equal value order. Return parts must be completed and in resalable condition. No returns after 30 days.

The following information is required to obtain a RMA number before returning product:

Your Name, Address, and Phone Number's
Model and Serial Number (Not Motor Number) Example: Model HD Series, Serial: 00125966 VIN Number of Vehicle
Date of Purchase
Nature of Problem

RMA and Product Serial Number must be on all paperwork and correspondence. Failure to obtain the required information or paperwork will result in \$25.00/item penalty and delay or denial of any warranty claim.

Under no circumstances shall the SELLER and/or MANUFACTURER be liable for any labor charged or travel time incurred in diagnosis for defects, removal, or reinstallation of this product, or any other contingent expenses.

Under no circumstances shall the SELLER and/or MANUFACTURER be liable for any damage or expenses insured by reason of the use or sale of any such equipment. This warranty does not apply to products which Diesel Performance Products, Inc. has determined to have been misused or abused, improperly maintained by the user, or where the malfunction or defect can be attributed to the use of non-genuine Diesel Performance Products, Inc. parts.

IN THE EVENT THAT THE BUYER DOES NOT AGREE WITH THIS AGREEMENT: THE BUYER MAY PROMPTLY RETURN THIS PRODUCT, IN A NEW AND UNUSED CONDITION, WITH A DATED PROOF OF PURCHASE, TO THE PLACE OF PURCHASE WITHIN THIRTY (30) DAYS FROM DATE OF PURCHASE FOR A FULL REFUND LESS SHIPPING.

THE INSTALLATION OF THIS PRODUCT INDICATES THAT THE BUYER HAS READ AND UNDERSTANDS THIS AGREEMENT AND ACCEPTS ITS TERMS AND CONDITIONS.