



PART NO. XD3007MS  
**XDP MAIN STUD KIT**

INSTALLATION MANUAL



CODE	DESCRIPTION	QTY
A	Main Stud	10
B	Washer	10
C	Nut	10
D	Side Cap Bolt	10
E	Chamfered Washer	10



**BEFORE REMOVING ANY PARTS FROM YOUR TRUCK, PLEASE COMPARE THE ITEMS YOU HAVE RECEIVED WITH THE PACKING LIST PROVIDED TO VERIFY THAT YOU HAVE EVERYTHING NECESSARY TO INSTALL YOUR NEW XDP MAIN STUD KIT.**



**BEFORE YOU BEGIN!** Ensure that the vehicle has not been in use and that the engine is cool to the touch. Always wear eye protection when working on any vehicle.

- 1** Clean all threads in the block using a thread cleaning chaser such as XD40125TC & XD40126TC to ensure proper thread engagement and accurate torque readings.
- 2** Clean and inspect all hardware before installing to ensure it is clean and free of shipping damages.
- 3** Install the studs into the block **HAND TIGHT!**
- 4** Proceed to install the main caps and check for any clearance issues or binding.
- 5** Lubricate the stud threads, bolts, nut threads, and washers with assembly lubricant such as XD541 X-TRA Slick Engine & Fastener Assembly Lubricant (sold separately). Install the washers and nuts onto the studs hand tight and then proceed to install the cross bolts. **NOTE:** The washers for the cross bolts are chamfered and the chamfered side must face the bolt head when installing.

**6** Following the torque sequence below tighten the nuts and bolts in three equal steps.

**7** 1st pass: 60ft lbs, 2nd pass: 120ft lbs, Final pass: 175ft lbs

**8** Following the sequence below, torque the side cap bolts to 90ft lbs

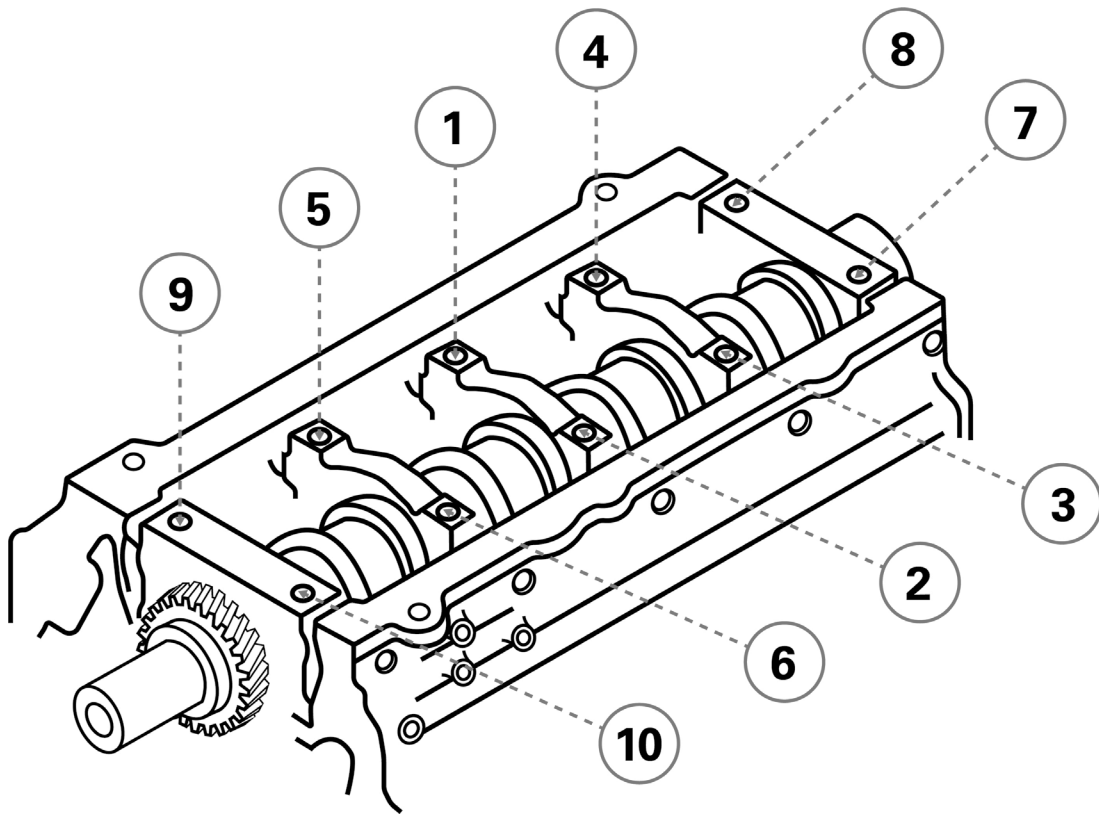
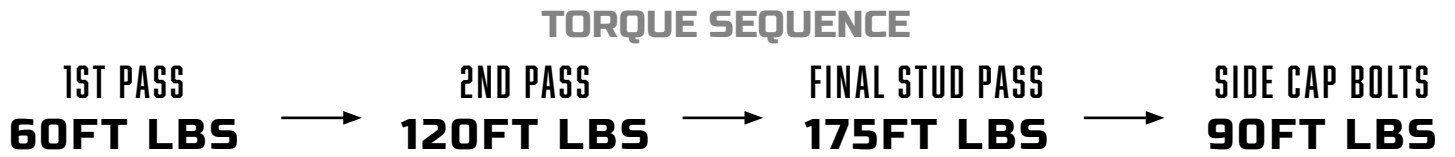

**NOTE:** After installation it is required to inspect the main bearing bores for proper size, and any out of round conditions as clamping force and tolerances will change. If necessary align hone the engine block. Main bores should be align honed using the same fasteners and lubricant that is being used during final assembly.