



PART NO. XD3010HS

XDP X220 SERIES HEAD STUD KIT

INSTALLATION MANUAL

CODE	DESCRIPTION	QTY
A	Short head stud	20
B	Long head stud (6.625")	6
C	12mm nut	26
D	12mm washer	26

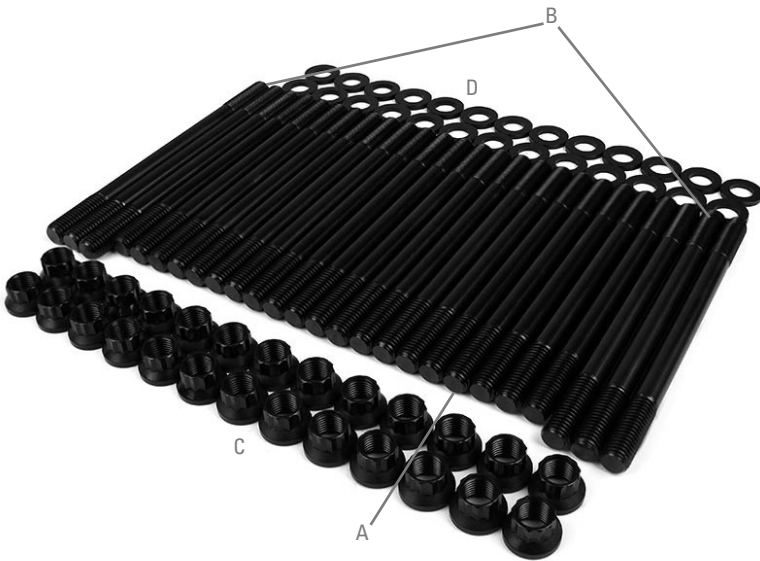

BEFORE REMOVING ANY PARTS FROM YOUR TRUCK, PLEASE COMPARE THE ITEMS YOU HAVE RECEIVED WITH THE PACKING LIST PROVIDED TO VERIFY THAT YOU HAVE EVERYTHING NECESSARY TO INSTALL YOUR NEW XDP X220 SERIES HEAD STUD KIT.



BEFORE YOU BEGIN! Ensure that the vehicle has not been in use and that the engine is cool to the touch. Always wear eye protection when working on any vehicle.

- 1 Verify the part number on the box, and the instructions match the part number for your vehicle application.
- 2 Thoroughly inspect all hardware and ensure proper length and fitment.
- 3 Using a thread chaser (Such as XD40125TC) chase all threads prior to installing your new head studs to ensure you get proper thread engagement and accurate torque readings.
- 4 Ensure that a thread sealer is used on any studs that protrude into a water jacket.
- 5 Using a 5mm allen key, install the studs into the block **HAND TIGHT!** NOTE: The longer 6.625" studs install along the exhaust manifold side of the cylinder head in positions 3, 6, 11, 14, 19, and 22
- 6 Proceed to install the cylinder head and be sure to check for any binding or misalignment.
- 7 Lubricate the threads of the studs, nuts, and washers with assembly lubricant such as XD541 X-TRA Slick Engine & Fastener Assembly lubricant (Sold separately).

- 8 Install the washers and nuts onto the studs tightening the nuts hand tight. NOTE: 2003+ model years will require machining to the factory rocker box at stud #24 location to allow clearance for the stud, nut, and washer.

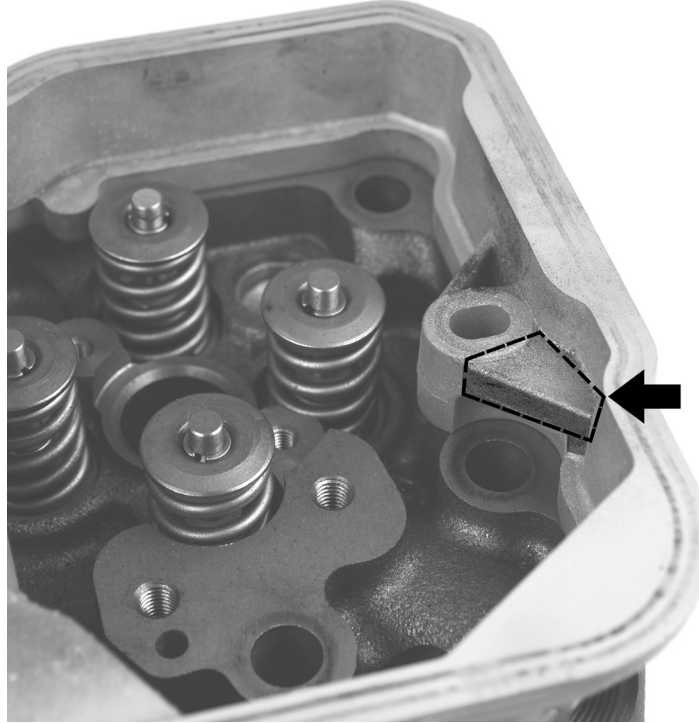

- 9 Following the torque sequence below in three steps, tighten the nuts to 40ft lbs, 80ft lbs, and then 125ft lbs.
Tech Tip: We recommend going over in sequence and double checking torque at 125ft lbs.

