



PART NO. XD3012MS
XDP MAIN STUD KIT

INSTALLATION MANUAL



CODE	DESCRIPTION	QTY
A	Main Stud	14
B	Washer	14
C	Nut	14



BEFORE REMOVING ANY PARTS FROM YOUR TRUCK, PLEASE COMPARE THE ITEMS YOU HAVE RECEIVED WITH THE PACKING LIST PROVIDED TO VERIFY THAT YOU HAVE EVERYTHING NECESSARY TO INSTALL YOUR NEW XDP MAIN STUD KIT.



BEFORE YOU BEGIN! Ensure that the vehicle has not been in use and that the engine is cool to the touch. Always wear eye protection when working on any vehicle.

- 1** Clean all threads in the block using a thread cleaning chaser such as XD40124TC to ensure proper thread engagement and accurate torque readings.
- 2** Clean and inspect all hardware before installing to ensure it is clean and free of shipping damages.
- 3** Install the studs into the block **HAND TIGHT!**
- 4** Proceed to install the main caps and check for any clearance issues or binding.
- 5** Lubricate the stud threads, nut threads, and washers with assembly lubricant such as XD541 X-TRA Slick Engine & Fastener Assembly Lubricant (sold separately).

6 Following the torque sequence below tighten the nuts in three equal steps.

7 1st pass 40ft lbs 2nd pass 80ft lbs 3rd pass 125ft lbs

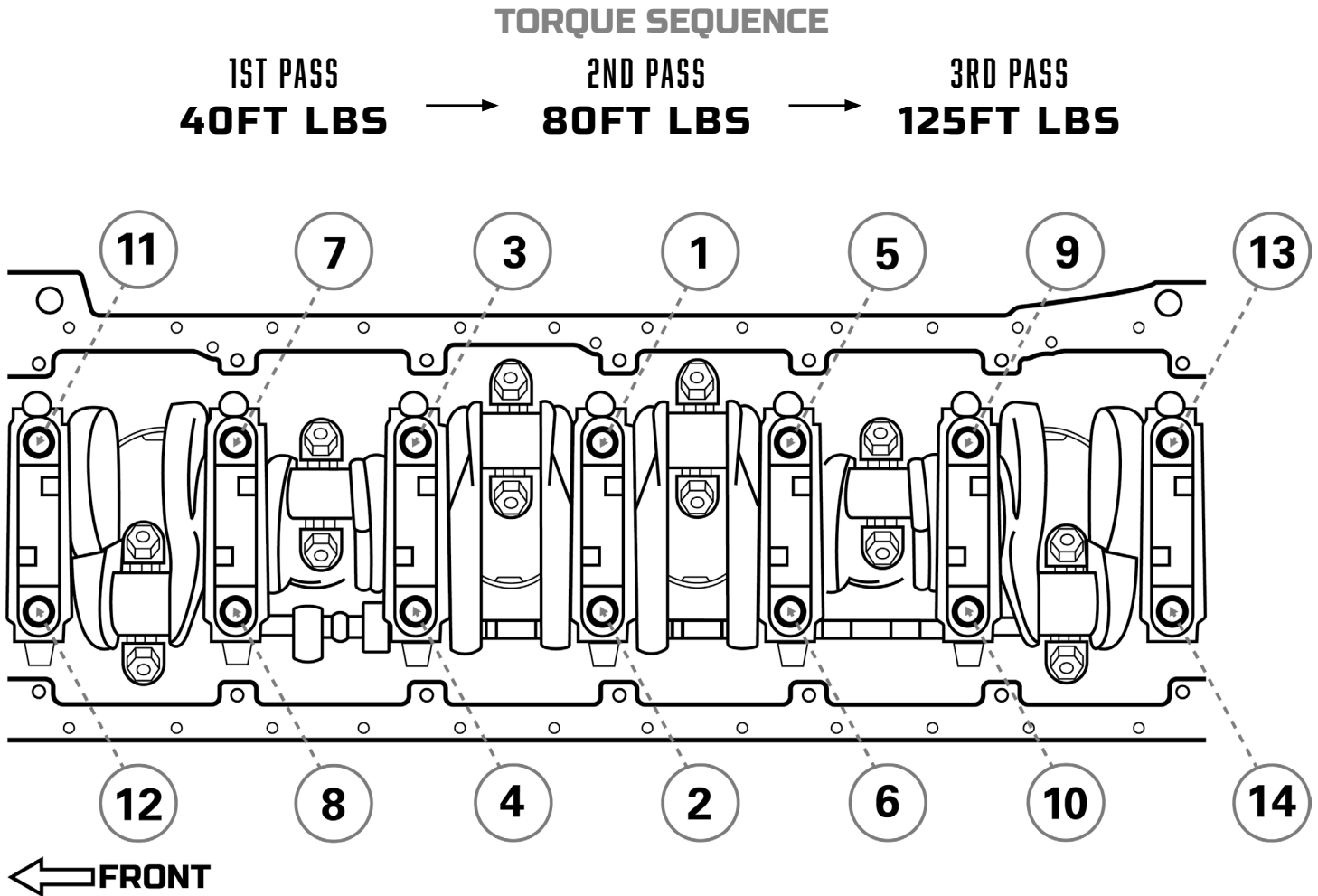

NOTE: After installation it is required to inspect the main bearing bores for proper size, and any out of round conditions as clamping force and tolerances will change. If necessary, align hone the engine block. Main bores should be align honed using the same fasteners and lubricant that is being used during final assembly. Modification to the oil pan adapter may be required. Check the top of the main studs for proper clearance and modify the adapter if necessary.